

Description

TP20D is a power surge protector; it is used for surge protection of commercial lighting power sources such as street lighting (Class I², Class II³), landscape lighting, and surge protection for power ports such as security, electrical appliances, and sockets. TP20D has a fully sealed enclosure that is fire, water, dust and IP65 rated. The lightning protection device adopts full mode protection, adopts UVT¹ technology, and has leakage current⁴ and freewheeling⁵ interruption function. The product is small and comes with L, N and PE cables for easy installation and application. The product's maximum protection lightning current is 20kA⁶, which can withstand 20kV⁷ surge voltage shock.

Applications

- Outdoor and Commercial LED Lighting
- Roadway lighting
- Traffic lighting
- Digital signage
- Security power supply
- Wash wall lighting
- Parking garage/lot lighting
- Flood lighting
- Tunnel lighting
- Street lighting



Agency	Standard	Agency File Number
CB	IEC61643-11	HU-002503
TUV	EN61643-11	50427906
CE	EN61643-11	50427907

Note:

1. UVT: It is an abbreviation of Ultra low voltage triggering technology. It is a design that absorb the high and low voltage energy of the surge in advance. It can absorb the surge energy more completely, and the residual voltage is low, and the protection effect on the back-end equipment is obvious.
2. Class I: In this paper, a luminaire that refers to "accessible conductive parts connected to protective earthing conductors in fixed wiring" (from IEC60598 - luminaires - general requirements and test - Chinese version).
3. Class II: In this paper, the term "light-protection protection is not only dependent on basic insulation, but also has additional safety measures, such as double insulation or reinforced insulation, but no protective grounding or protection measures depending on installation conditions" (from IEC60598- Luminaires - General Requirements and Tests - Chinese version).
4. Leakage current: In this paper, the current flowing through the SPD does not occur when the power is connected. For example, zinc oxide varistor is a device with leakage characteristics.
5. Freewheeling: Current from the connected power source that flows through the SPD during and after the discharge current passes. For example, gas discharge tubes and thyristors are devices with freewheeling characteristics (cited from IEC61643-11).
6. 20kA: refers to the maximum discharge current (I_{max}) in the 8/20 μ s surge waveform test.
7. 20kV: refers to the nominal discharge voltage (V_n) in the 1.2/50 μ s surge waveform test.

Specification	Test Standard: EN61643-11/ UL1449 ^{4th}	TP20D	Units
Electrical parameters			
Rated operating voltage ⁸		277	VAC
Max. Continuous voltage ⁹		277	VAC
Cross-section area (Flexible)		1.3/16	mm ² /AWG
Mounting on		Custom	
Surge parameter			
Norminal discharge current ¹⁰ (8/20 μ s) (I_n)		10	kA
Max. discharge current ¹¹ (8/20 μ s) (I_{max})		20	kA
Nominal discharge voltage ¹² (1.2/50 μ s) (V_n)		20	kV
Maximum discharge voltage ¹³ (1.2/50 μ s) (V_{max})		40	kV
Voltage protection level ¹⁴ (U_p)			
	L-N	1100	V
	L-PE	1100	V
	N-PE	1800	V

Placement and transportation parameters			
	Enclosure material	ABS765A(94V0)	
	Operating temperature range	-40~80	°C
	Ingress Protection	IP65	
	Size	79.5×38.6×16.5	mm
	Weight (One piece)	77(±3)	g
	Package size	315×290×272	mm
	Package quantity	150	pcs

Note:

8. Rated operating voltage: The normal AC mains voltage rating assigned by the manufacturer to the SPD (cited from UL1449).
9. Max. Continuous voltage: The maximum rms voltage that can be continuously applied to the SPD (cited from IEC61643-11).
10. Nominal discharge current: The current peak selected by the manufacturer. With SPD, the current waveform is 8/20μs, and the SPD remains functional after 15 surges (from UL1449).
11. Maximum discharge current: The peak value of the SPD current flowing through the 8/20 waveform and the manufacturer's claimed amplitude. Belongs to the T2 test type (quoted from IEC61643-11).
12. Nominal discharge voltage: The discharge open circuit voltage peak with a 1.2/50 μs waveform and flowing through the SPD (this parameter is equivalent to the open circuit voltage Uoc defined by the T3 test in IEC61643-11).
13. Maximum discharge voltage: The peak value of the SPD voltage flowing through the 1.2/50 waveform and the manufacturer's claimed amplitude (this is twice the open circuit voltage of the T3 test in IEC61643-11). (2Uoc).
14. Voltage protection level: The maximum voltage expected to occur between the two ends of the SPD due to the application of a specified gradient of the impulse voltage and the specified amplitude and the inrush current of the waveform (cited from IEC61643-11).

Surge test characteristics of TP20D

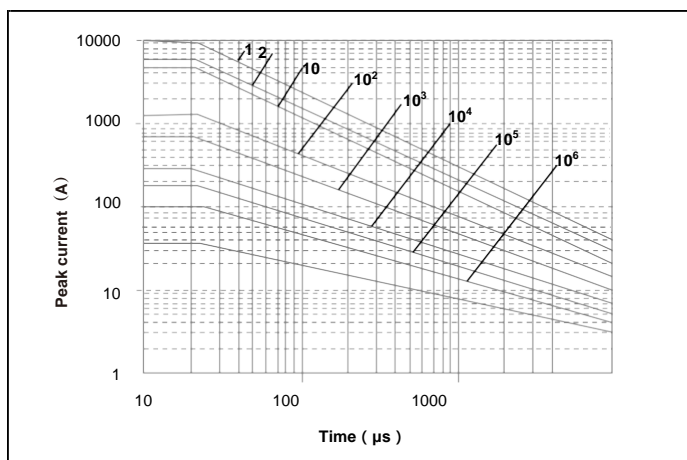

Test	Surge	Strikes
Pulse Rating (8/20μs)	20kA	1
	15kA	2
	10kA	15
	5.0 kA	45
	2.5 kA	200
TTF DATE	20kA	2
	10kA	50

Features

- Nominal discharge voltage: 20kV, 1.2/50 μ s;
- Maximum discharge current: 20kA, 8/20 μ s;
- Executive standard: IEC/EN:61643-11/UL1449^{4th};
- Parallel SPD equipment;
- UVT ultra-low voltage technology, more adequate protection;
- With lead wire for easy connection;
- Ultra-thin shape: 79.5 × 38.6 × 16.5, easy to reset;
- IP65 waterproof and dustproof;
- Installation of Class I and Class II lamps that meet the rated voltage of 110 to 277 V_{AC};
- Excellent performance after TTF's rigorous testing.
- Certified by CB, UL, TUV and CE.
- A variety of wiring methods are combined to meet string and parallel wiring requirements.

About UVT

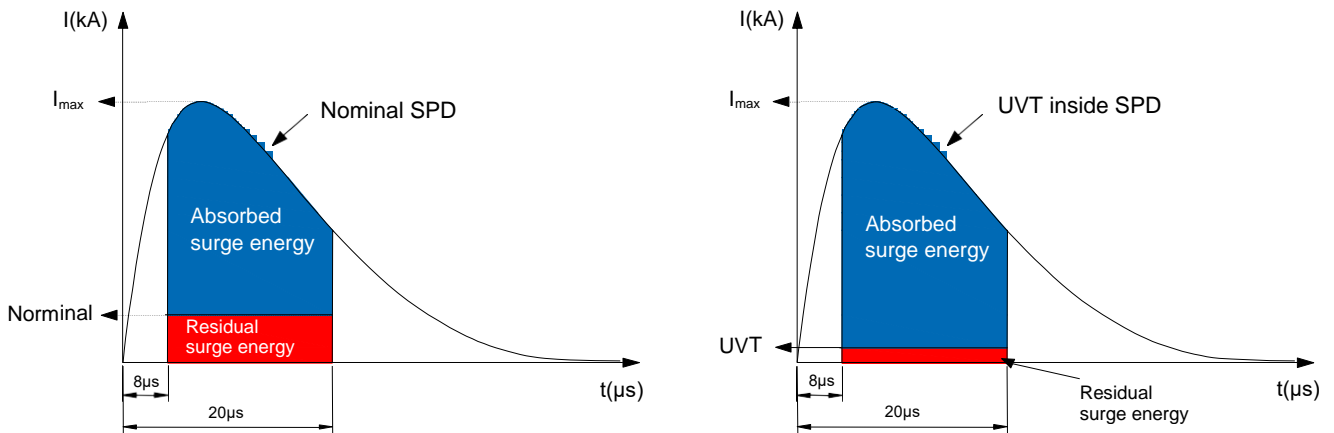

After many tests, the circuit model was established and the ultra-low voltage triggering scheme (UVT1) was introduced. It was applied to the new totem surge suppressor, which greatly improved the surge protection efficiency and played a good role in the protected equipment. Surge protection effect.

Application/ Inatallation Schematic

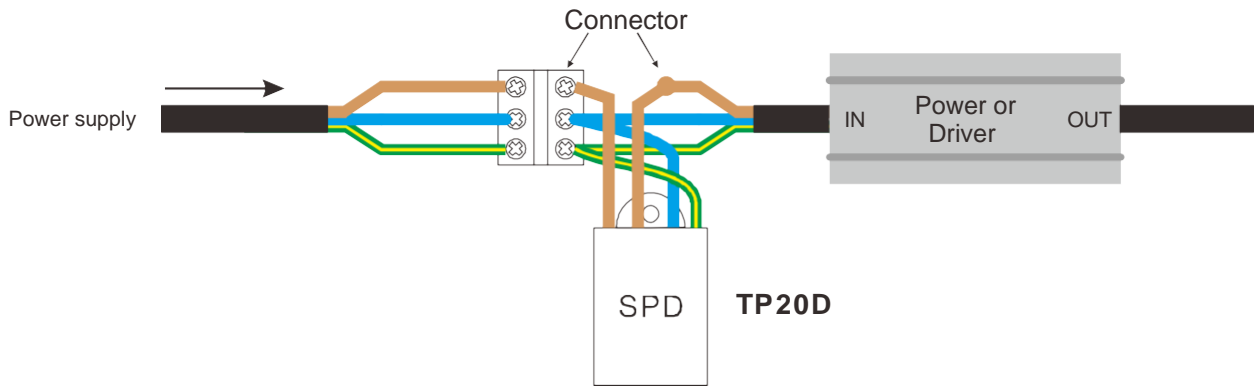

Notes:

1. The connection line of the lightning arrester will be connected after tining.
2. If there are no wiring terminals, wires should be welded, and the welds need to do isolation treatment.
3. L----Brown; N----Blue; P E---Yellow and Green.

Dimensions

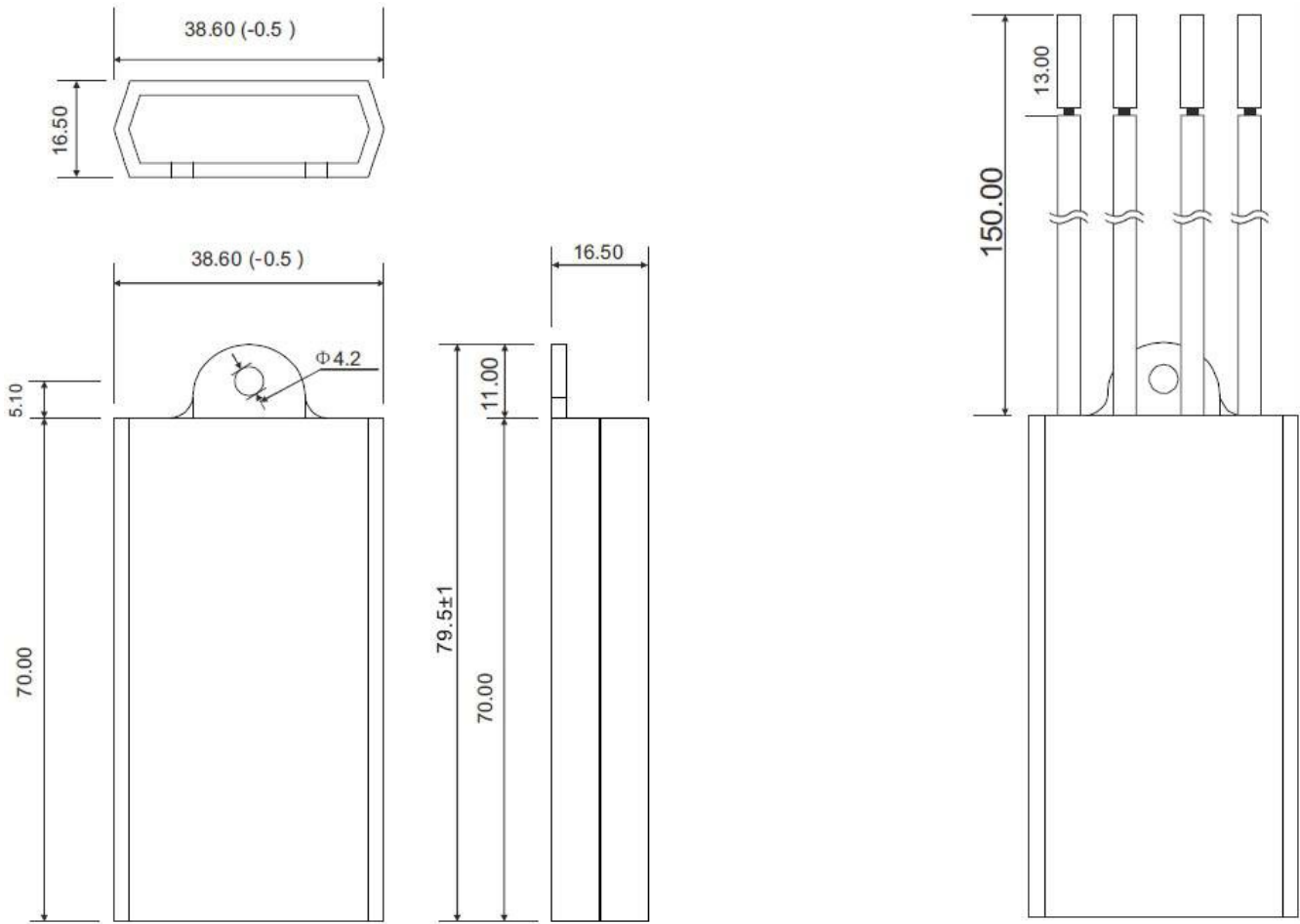

Disclaimer Notice - Information furnished is believed to be accurate and reliable. However, users should independently evaluate the suitability of and test each product selected for their own applications. Products are not designed for, and may not be used in, all applications.