

**SINOMACH**

**SINOMACH-HI INTERNATIONAL EQUIPMENT CO.,LTD.**

# ZG017S

Mini Excavator

Engine Model: Kubota D902  
Gross Power: 11.8kW/2300rpm  
Operating Weight: 1,800kg



国机重工集团国际装备有限公司

SINOMACH-HI INTERNATIONAL EQUIPMENT CO., LTD.

Add:No.898 West Huang He Road, Changzhou city, Jiangsu Province, China

PC:213136

Tel:86-519-86781288 86752400

Fax:86-519-86781387

Http://www.sinomachiglobal.com

E-mail:sales@changlin.com.cn service@changlin.com.cn



V.24091



国机重工集团国际装备有限公司  
SINOMACH-HI INTERNATIONAL EQUIPMENT CO.,LTD.

## WALK-AROUND

The zero-tail swing ZG017S is the perfect choice for working in tight conditions. High performance in a compact design for greater versatility and controllability.

AUXILIARY PIPING



OFFSET BOOM



FOLDABLE BLADE



HIGH SAFETY FOUR POST CANOPY (CAB OPTIONAL)



TELESCOPIC TRACK



## HIGH PERFORMANCE IN TIGHT CONDITIONS

### A COMPACT MODEL WITH HIGH PERFORMANCE

ZG017S with OPG/TOPS canopy (cab) provides excellent visibility, stability, optimal comfort, and safety. For tough jobs in tight corners that demand precision control and state-of-the-art performance.

ZG017S is ready to work, offering following advanced features: Zero-tail swing, hydraulic retractable undercarriage, boom swing, foldable dozer blade. Featuring high reliability, low operating cost, and superior efficiency, and you've got the ideal mini for a wide range of modern jobs.

#### Zero-tail Swing

With zero-tail swing, even the tightest space becomes an efficient work place. The tail always stays within the width of the tracks (when extended) and lets you turn the canopy throughout its 360-degree turning radius with complete confidence and safety. Starting point by developing our zero-tail ZG017S, balance, fast and smooth operation was our main target. It results in a compact excavator with excellent balance and comes to its full potential in urban environments, landscaping, and small demolition in and outside buildings.

#### Extended Undercarriage

With the standard hydraulic retractable undercarriage passing through a narrow doorway or gate is easy. Extended undercarriage provides the operator better stability, lifting and loading performance.

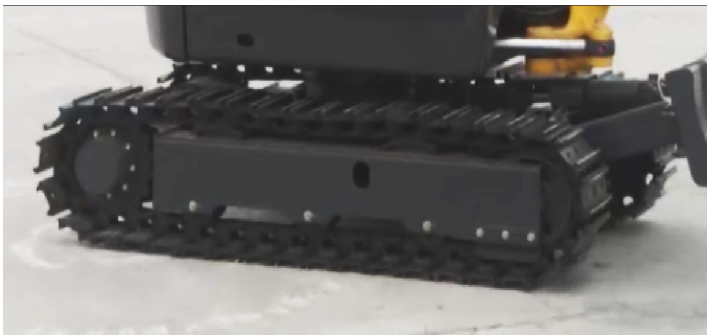

#### Boom Swing

The left and right boom swing angle supports complex operating conditions like parallel wall digging or working in narrow spaces.

#### Foldable blade

Through two pin shafts, the dozer blade can be folded and expanded easily. In a confined space, the blade width can be adjusted arbitrarily, which makes the construction much easier.



## OPERATIONAL COMFORT

### LARGE OPERATOR ENVIRONMENT WITH ERGONOMIC CONTROL LAYOUT

The ZG017S provides an uncompromised operator environment – which, together with excellent visibility, provides unmatched operator comfort and safety. This machine is built around the operator – providing optimal ergonomics for operators of all sizes. Access to the seat is convenient thanks to the large entry.



## EASY ACCESS FOR MAINTENANCE

### EASY SERVICE ACCESS

ZG017S is developed with taking particular attention to ease of service access. With a single access point for the daily maintenance of all main components, fuel level gauge and refuelling through the lockable cap.

The ZG017S is designed for lower maintenance cost with longer service intervals- resulting in more machine availability on-site. Meanwhile, skilled technicians are available to provide extra support when needed.



### EASY MAINTENANCE

- Fuel filter
- Water separator
- Air filter
- Engine oil filter
- Engine oil level check
- Coolant
- Start motor
- DC generator
- Battery
- Main switch
- Radiator & Oil cooler

## SPECIFICATIONS

ENGINE	
Model	KUBOTA D902
Type	Vertical, water cool, 4-cycle
No. of cylinder	3
Emission	EPA Tier 4 Final/Europe Stage V
Displacement	0.898L
Power output	11.8kW/2300rpm
HYDRAULIC SYSTEM	
Type	Axial piston-variable displacement
Max. hydraulic flow	28L/min
DIGGING FORCE (ISO6015)	
Bucket digging force	16kN
Arm digging force	9.5kN
BUCKET	
Type	Backhoe bucket
Bucket capacity	0.04 m <sup>3</sup>
Bucket width	450 mm
DRIVE SYSTEM	
Type	Axial piston motor
Track roller	2×3
Track shoes	2×37
Travel speed	2.2/4.3km/h
Max. Drawbar pull	18kN
Grade ability	58%
SWING SYSTEM	
Swing motor type	Cycloidal motor
Swing speed	0-9.5r/min
Brake type	Pressure release mechanical braking
REFILLING CAPACITIES & LUBRICATIONS	
Fuel tank	19L
Cooling system	5L
Engine oil	3.7L
Hydraulic oil tank	20L
OPERATING WEIGHT AND GROUND PRESSURE	
Shoe width	230mm
Ground pressure	29kPa
Operating weight	1800kg

DIMENSIONS		mm
A	Transport Length (arm lowered)	3570
B	Overall height(top of canopy)	2400
C	Undercarriage Width (Retracted)	990
D	Undercarriage Width (Extended)	1300
E	Undercarriage Length	1587
F	Upperbody width (zero tail)	990

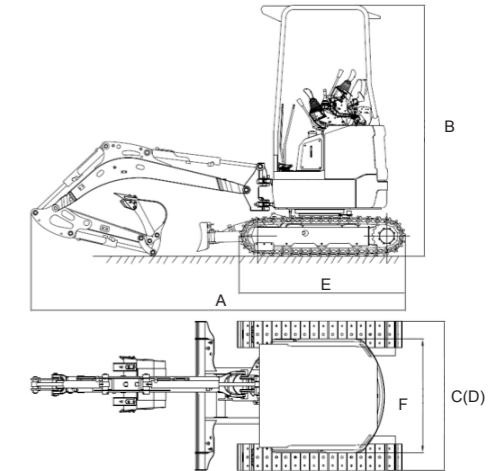

WORKING RANGE		mm
A	Max. digging height	3535
B	Max. dumping height	2445
C	Max. digging depth	2270
D	Max. vertical digging depth	1910
E	Max. digging radius	3910
F	Max. digging radius, at ground level	3845
G	Min. swing radius of work equipment	1495
H	Min. tail swing radius	650
I	Ground clearance of counterweight	450
J	Maximum Dozer Lift Height	280
K	Maximum Dozer Dig Depth	190
L	Maximum Boom Offset (LH)	385
M	Maximum Boom Offset (RH)	510
N	Boom Swing Angle (LH&RH)	57°/61°

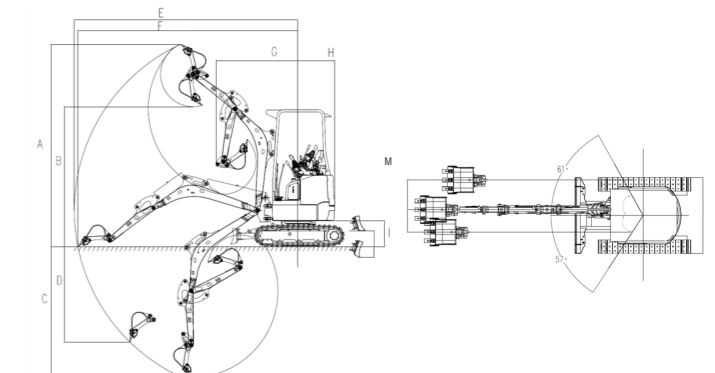

\* The specifications are subject to change without notice. The pictures may include options. The actual color & appearance of the product may differ from what is shown.