

WH-25/30S-H

STAINLESS HAND PALLET TRUCK

- ◆ All metal parts made completely stainless steel, including hydraulic pump, fork frame, handle and so on.
- ◆ Ideal transport aid for application in damp or harsh environments such as meat or fish processing plants, dairies, pharmaceutical and chemical industry.
- ◆ Specially designed for applications where hygiene is of utmost importance.

MODEL		WH-25S-H	WH-30S-H
FEATURE			
1.1	Capacity	kg	2500
1.2	Pump type	Stainless steel Pump	
WHEEL			
2.1	Wheel type	Nylon	
2.2	Size of steering wheel	ΦD mm	180x50
2.3	Size of load wheel(single)	Φd mm	74x93
2.4	Size of load wheel(tandem)	Φd mm	80x70
DIMENSION			
3.1	Min. fork height	H1 mm	85/75
3.2	Max.fork height	H mm	195/185
3.3	Lifting height	h mm	115
3.4	Individual Fork Width	S mm	160
3.5	Fork overall width	W mm	550/685
3.6	Fork length	L mm	1150/1220
3.7	Weight	kg	70-80

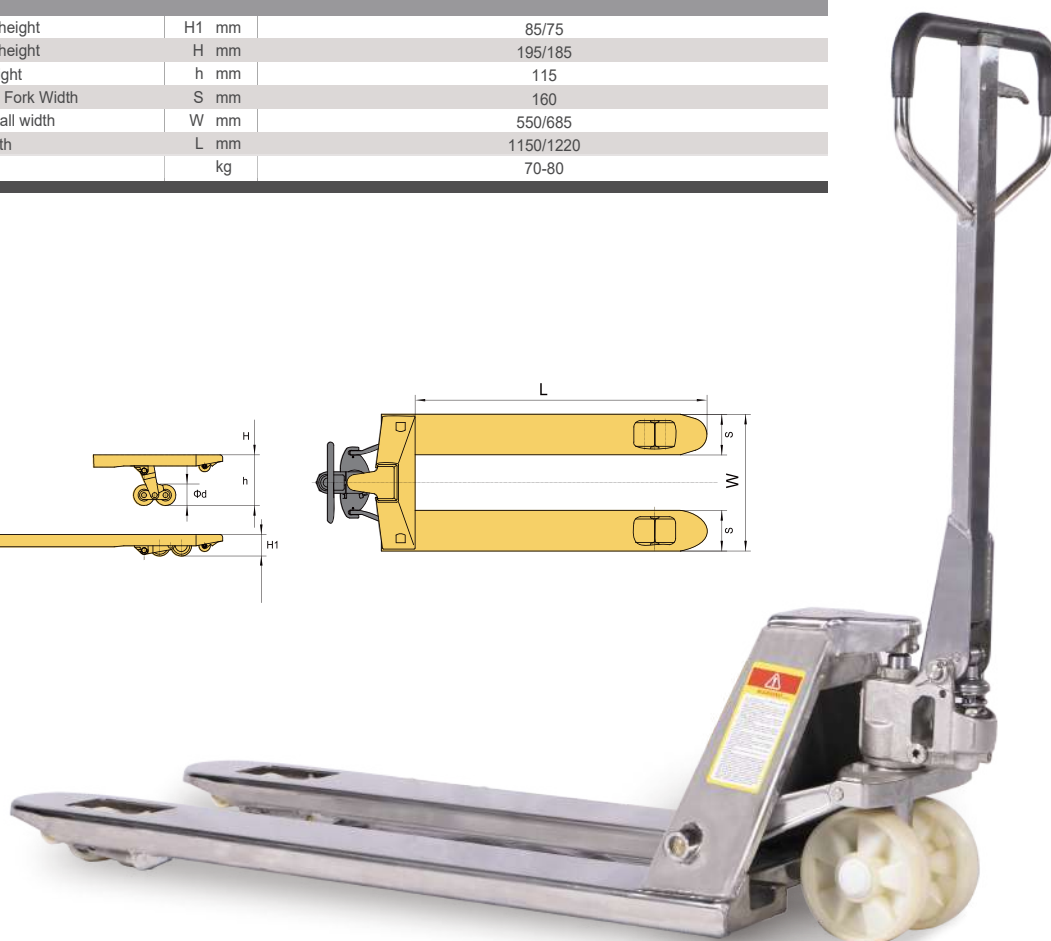
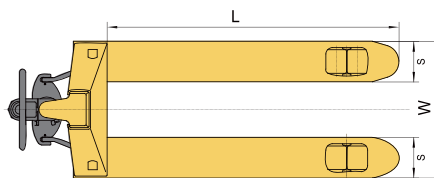
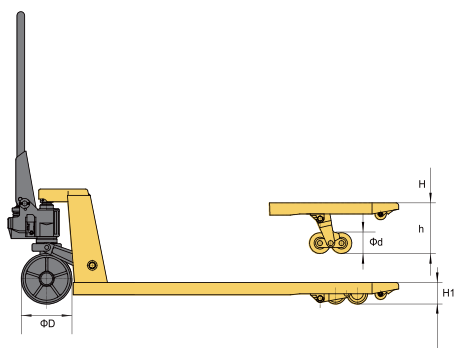

Hand Pallet Truck



- ◆ With pressure relief valve and overload valve to prevent pump damages when loads exceeds weight limits.



- ◆ Nylon fork rollers as standard option for damp or harsh environments applications.

