

WH-20L-51H

Low Profile Hand Pallet Truck

- ◆ Easy access to the lowest pallets and containers with the minimum floor clearance of 51mm only.
- ◆ High quality surface treatment.
- ◆ Reliable Pump, Integrated BF pump, more than 1 million pcs use in China per year, high reliable quality, extremely low failure rate.

MODEL	WH-20L-51	WH-25L-51	
FEATURE			
1.1 capacity	kg	2000	2500
1.2 pump type		BF	BF
WHEEL			
2.1 wheel(drive/load) Type		PU	PU
2.2 size of steering wheel	ΦD mm	180*50	180*50
2.3 size of Loading wheel(double wheel)	Φd mm	50*70	50*70
DIMENSIONS			
3.1 lifting height	h mm	90	90
3.2 max. fork lifting height	H mm	141	141
3.3 lowered height of fork	H1 mm	51	51
3.4 fork outside distance	W mm	550/685	550/685
3.5 fork length	L mm	1150x160x30/1220x160x30	1150x160x30/1220x160x30
3.6 fork width	S mm	160	160
3.7 fork thickness	mm	3	3
3.8 handle		Coated square handle	Coated square handle

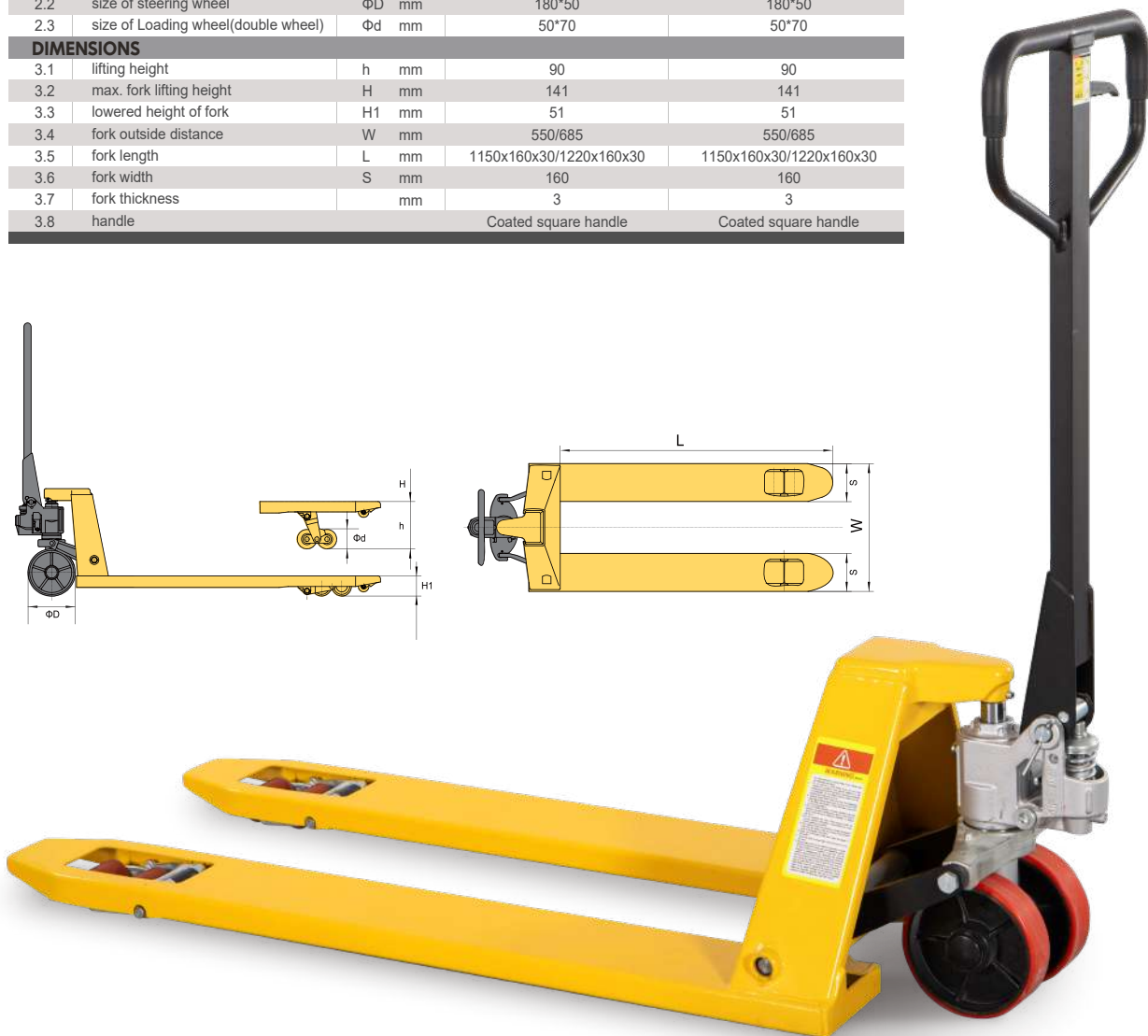
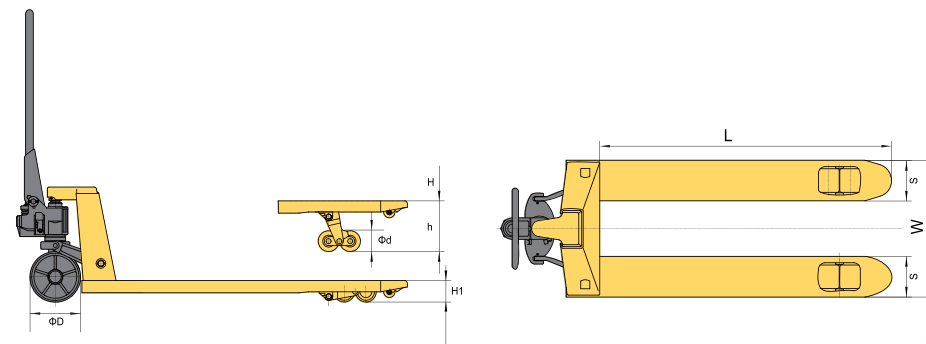

Hand Pallet Truck

STRONG CHASSIS DESIGN



- ◆ Reinforced half Stiffener on both sides.

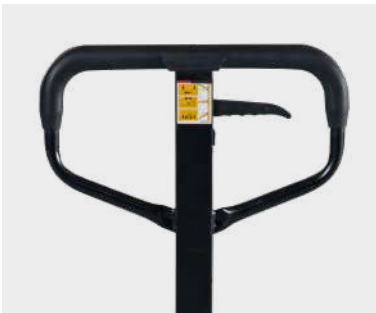

- ◆ **Ergonomic handle**
Square handle with rubber coated, comfort and easy operation.



- ◆ Extra reinforcement rod on top of the chassis.
Leads to a longer chassis life time.



- ◆ **Adjustable push rod :**
Adjustable push rod design, after 1-2 years use, due to wrong load center, there might be situation with 2 forks not in the same even level, the customer can adjust the forks to even level with the adjustable push rod.