

# PWH20/25/30-III

## HAND PALLET TRUCK

- ◆ Fully automatic robot welding chassis, make sure the the precision, consistency, lead to reliable quality and longer life time.
- ◆ High quality and easy maintenance pump equipped. More than 50 million pieces produced each year, high reliable quality and extremely low failure rate.
- ◆ Small pump body removable design. If there are any failure on the small pump, it can be fixed via only changing it rather than replace the whole pump assembly. Save cost and easy maintenance.
- ◆ High quality spring used to make sure long life time.



| MODEL             |                                     | PWH20-III | PWH25-III          |                    |        | PWH30-III |                    |        |        |
|-------------------|-------------------------------------|-----------|--------------------|--------------------|--------|-----------|--------------------|--------|--------|
| <b>FEATURE</b>    |                                     |           |                    |                    |        |           |                    |        |        |
| 1.1               | capacity                            | kg        | 2000               | 2500               |        |           | 3000               |        |        |
| 1.2               | pump type                           |           | DB Casted Pump     | DF Casted Pump     |        |           | DF Casted Pump     |        |        |
| <b>WHEEL</b>      |                                     |           |                    |                    |        |           |                    |        |        |
| 2.1               | wheel(drive/load) Type              |           | PU/RU/Nylon        | PU/RU/Nylon        |        |           | PU/RU/Nylon        |        |        |
| 2.2               | size of steering wheel              | ΦD mm     | 160*50             | 180*50             | 180*50 | 200*50    | 180*50             | 180*50 | 200*50 |
| 2.3               | size of Loading wheel(single wheel) | Φd mm     | 70*80              | 74*93              | 80*93  | 80*93     | 74*93              | 80*93  | 80*93  |
| 2.4               | size of Loading wheel(double wheel) | Φd mm     | 70*60              | 74*70              | 80*70  | 80*70     | 74*70              | 80*70  | 80*70  |
| <b>DIMENSIONS</b> |                                     |           |                    |                    |        |           |                    |        |        |
| 3.1               | lifting height                      | h mm      | 115                | 115                |        |           | 115                |        |        |
| 3.2               | max. fork lifting height            | H mm      | 190                | 195                | 200    | 200       | 195                | 200    | 200    |
| 3.3               | Lowered height of fork              | H1 mm     | 75                 | 75                 | 85     | 85        | 75                 | 85     | 85     |
| 3.4               | fork outside distance               | W mm      | 520/550/685        | 520/550/685        |        |           | 520/550/685        |        |        |
| 3.5               | fork length                         | L mm      | 900/1100/1150/1220 | 900/1100/1150/1220 |        |           | 900/1100/1150/1220 |        |        |
| 3.6               | fork width                          | S mm      | 150                | 160                |        |           | 160                |        |        |
| 3.7               | steel thickness(after painting)     | mm        | 2.5                | 3                  |        |           | 3.75               |        |        |
| 3.8               | weight                              | kg        | 40-57              | 61-68              |        |           | 71-79              |        |        |

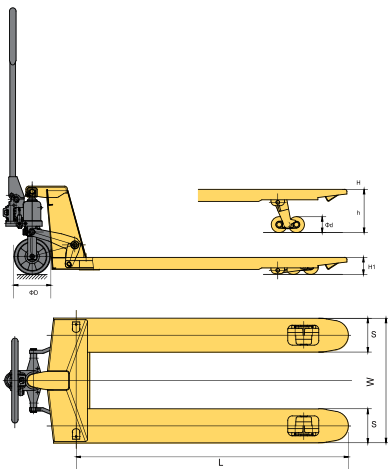

# Hand Pallet Truck



- ◆ Well designed opening space for loading wheel, better protection for the wheel, and push rod, wheel fork etc.



- ◆ Tough chassis design to ensure the stability and reliability.
- ◆ Extra supporting rod added, tough and longer chassis life time.



- ◆ Rigid rock arm design.



- ◆ Bridge plate for 2.0T; Half length stiffener for 2.5T; Full length stiffener for 3T.



- ◆ Adjustable push rod design. In case of the hand pallet truck used after one year, the 2 forks might not be on the same level, with this design, it still can be adjustable.

- ◆ Reliable quality loading and guide roller, good quality screw to ensure the stability, Life time is much longer than others.
- ◆ Good quality wheels and bearings.



- ◆ Unique Fork design  
Grooved forks, punched by heavy presser, much stronger than normal flat fork. 400kgs fork intensity increases at static load.



- ◆ Option of different coating material for both steering wheel and fork rollers.