

# MRS SERIES

## Electric Reach Stacker

### INTRODUCTION

- ◆ Mast Reach Stacker is the perfect selection combines the counterbalance stacker with the reach-mast, where a short length is needed with a higher lift capacity required.

In combination with the forward function are especially suit to use in a narrow space, the compact structure make this stacker comes with an excellent performance.



# ELECTRIC REACH STACKER



- ◆ **Handle**  
All operating elements on the handle are easy to reach.
- ◆ **Electric power steering (Optional)**  
Electric power steering brings effortless operating and easy maneuvering even in narrow spaces.



- ◆ **Reach Mast**  
In comparison with common counter balance heavy stacker, it is not only have same stability, but also have flexible.



- ◆ The innovative AC drive system offers strong power, accurate control, excellent performance. High strength gearbox with long working life. Low noise but durable hydraulic unit, good quality cylinder as well as hose ensure high reliability of hydraulic system.

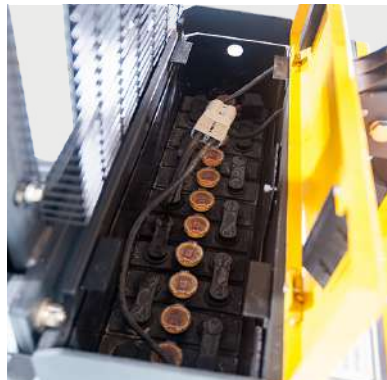

- ◆ **Standard battery**  
Long operating time with high capacity.



- ◆ Larger front wheels, easier to roll over uneven grounds



- ◆ Adjustable forged forks, no baselegs, suited to any type of pallet truck, similar to a traditional forklift. Tilting fork carriage for efficient load placement operations.
- ◆ **Side shift (Optional)**  
Side shift allows the load carried to be moved to the left and the right, especially for small space, Cargo can be accurately placed on the shelf.



- ◆ **Optional foldable platform & protective arm**  
Suspension foldable platform with protective arms. The ergonomically designed foldable platform in combination with protective arms makes operations faster and safer.

# SPECIFICATIONS

MODEL			MRS12D	MRS15D	MRS20D	MRS15T	MRS20T
<b>CHARACTERISTICS</b>							
1.1	Mast type			Duplex		Triplex	Triplex
1.2	Mast profile		C model/H model		H model	H model	H model
1.3	Type of drive			Full electric		Full electric	Full electric
1.4	Operator type			Walkie/Rider		Walkie/Rider	Walkie/Rider
1.5	Capacity	Q kg	1200	1500	2000	1500	2000
1.6	Load center	C mm	500	600	600	600	600
1.7	Wheel base	Y mm	1400	1400	1550	1400	1550
1.8	Reach distance	L1 mm	400	500	500	500	500
1.9	Electric power steering(EPS)					standard equipped	
<b>WEIGHT</b>							
2.1	Service weight without battery	kg	1626	1726	1926	1895	2120
2.2	Service weight with battery	kg	1836	1936	2146	2105	2330
<b>WHEEL</b>							
3.1	Wheel type		PU	PU	PU	PU	PU
3.2	Size of front wheels	Φd mm	∅210	∅210	∅210	∅210	∅210
3.3	Size of drive wheels	ΦD mm	∅230	∅230	∅230	∅230	∅230
3.4	Wheels quantity	pcs					
<b>CHASSIS</b>							
4.1	Mast lower height	h1 mm		2040		206	2065
4.2	Overall length (without platform)	mm	2700	2800	2960	2805	2805
4.3	Overall length (with platform)	L mm	3240	3340	3500	3345	3345
4.4	Rear body width	W1 mm	850	850	850	850	850
4.5	Overall width	W2 mm	990	990	990	990	1023
4.6	Height of tiller arm in drive position min./max.	H mm			1030-1330		
4.7	Rear body height	H1 mm	860	860	860	860	860
4.8	Mast extend height	h2 mm	3815	3810	3810	5310	5310
<b>SPECIFICATIONS</b>							
5.1	Lifting height	h mm		70~3000		70~4500	
5.2	Clearance	H2 mm	60	60	60	60	60
5.3	Fork length	slell mm	1070	1070	1070	1070	1070
5.4	Overall fork width	W mm	200~680	200~680	240~680	200~680	200~680
5.5	Fork width	S mm	100	100	120	100	120
5.6	Fork thickness	mm	30	35	40	35	40
5.7	Min. turning radius	Wα2 mm	1600	1680	1830	1680	1830
5.8	Lowered height of fork	H3 mm	70	70	70	70	70
5.9	Freelift height	mm	—	—	—	1530	1530
5.10	Fork tilting degree (forward/backward)	°	2/5	2/5	2/5	2/5	2/5
5.11	Aisle width(800*1200mm pallet):horizontal/vertical (without platform)	Ast mm	2742	2842	3000	2823	3130
5.12	Aisle width(800*1200mm pallet):horizontal/vertical (with platform)	Ast mm	3282	3382	3540	3363	3670
5.13	Aisle width(1000*1200mm pallet):horizontal/vertical (without platform)	Ast mm	2789	2889	3040	2870	3175
5.14	Aisle width(1000*1200mm pallet):horizontal/vertical (with platform)	Ast mm	3329	3429	3580	3410	3715
<b>SPECIFICATIONS</b>							
6.1	Travel speed	laden	km/h	5	5	5	5
		unladen	km/h	5.3	5.3	5.3	5.3
6.2	Lift speed	laden	mm/s	100	100	100	105 ± 10%
		unladen	mm/s	140	140	140	155 ± 10%
6.3	Lower speed	laden	mm/s	170	170	170	180 ± 10%
		unladen	mm/s	130	130	130	100 ± 10%
6.4	Gradeability	laden	%	5	5	5	5
		unladen	%	7	7	7	7
<b>PERFORMANCE</b>							
7.1	Brake type					electromagnetic	
7.2	Drive motor	kw				2.5	
7.3	Lift motor	kw				3	
7.4	Battery voltage/capacity	V/Ah				24V 210/270/340Ah	
7.5	Battery weight	kg				210	
7.6	Battery size	mm				790×210×576	
7.7	Control system					1232E (CURTIS)	

**Note:**

1kgs=2.2lbs, 5.4mm=1inch

● standard ○ option

If there are improvements of technical parameters or configurations, no further notice will be given.

The diagram shown may contain non-standard configurations.

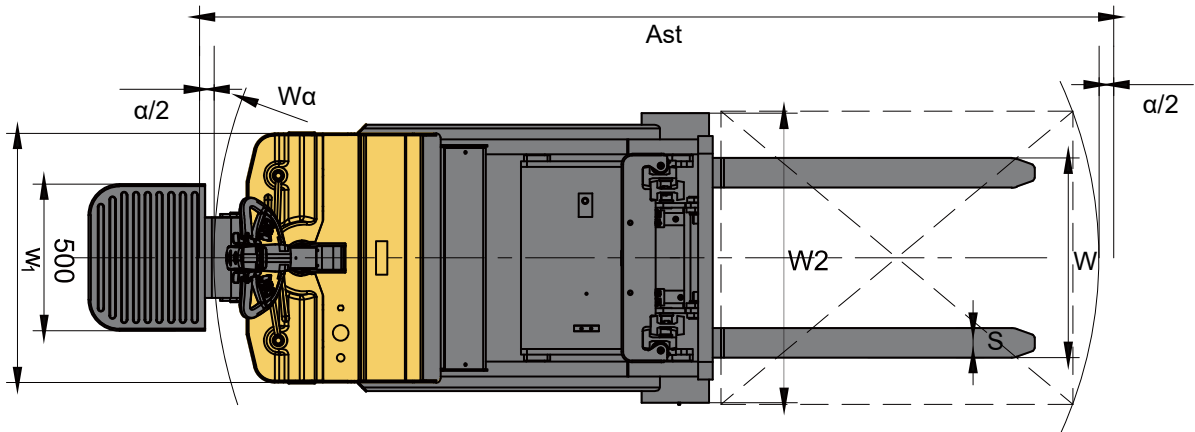
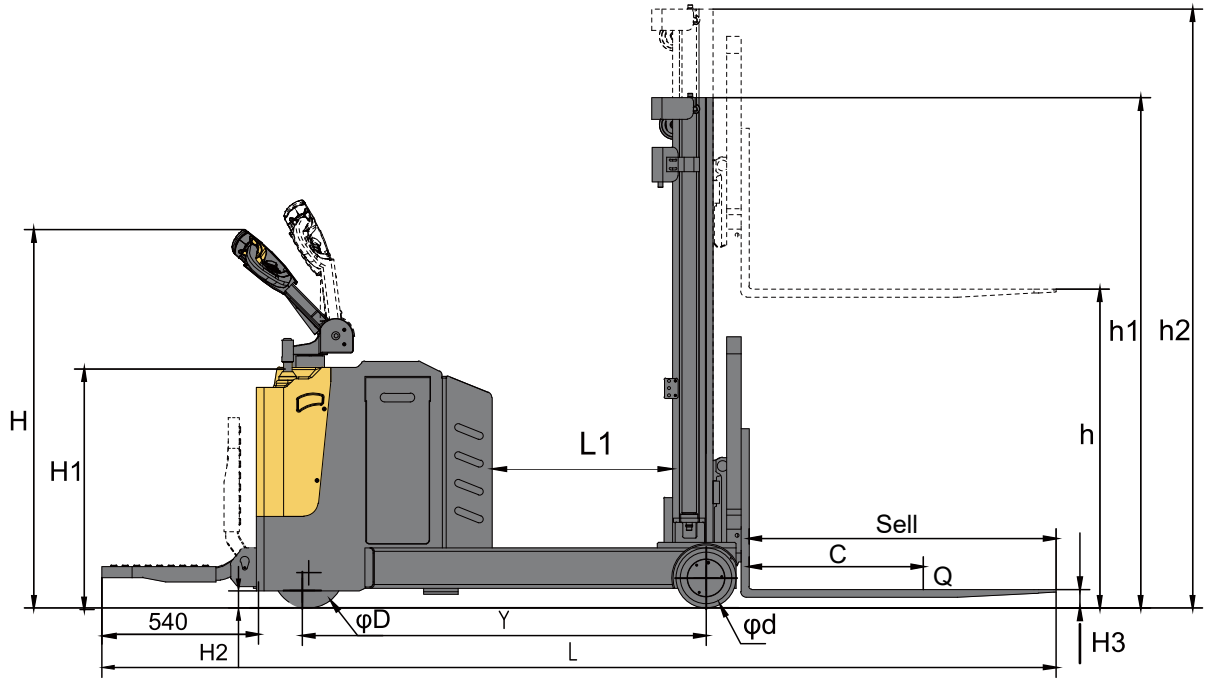

**LOAD CHART MRS12D (with Duplex)**

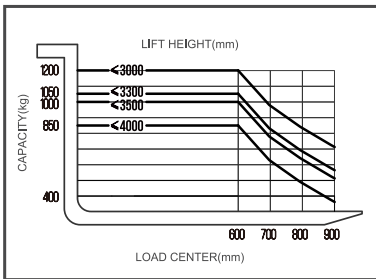

**LOAD CHART MRS15D (with Duplex)**

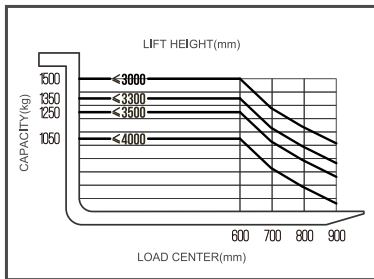

**LOAD CHART MRS20D (with Duplex)**

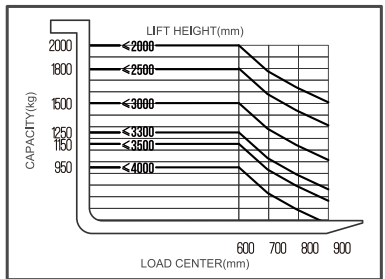

**LOAD CHART MRS15T (with Triplex)**

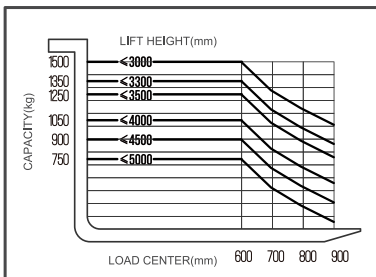

**LOAD CHART MRS20T (with Triplex)**

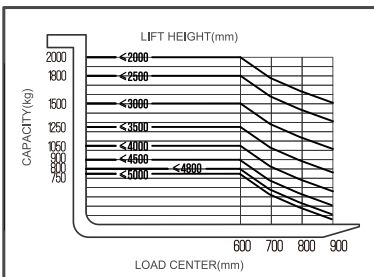

# MAST OPTION

MAST OPTION						
MODEL	MAST TYPE	LIFTING HEIGHT (mm)	MAST LOWER HEIGHT (mm)	MAST EXTEND HEIGHT (mm)	FRELIFT HEIGHT (mm)	SERVICE WEIGHT WITH BATTERY (kg)
MRS12D	DUPLEX	1600	2120	2415	/	1586
		2500	1790	3315		1736
		3000	2040	3815		1836
		3300	2190	4115		1900
		3500	2290	4315		1936
		4000	2545	4815		1960
MRS15D	DUPLEX	1600	2120	2410	/	1686
		2500	1790	3310		1836
		3000	2040	3810		1936
		3300	2190	4110		2000
		3500	2290	4310		2036
		4000	2545	4810		2060
MRS12FD	DUPLEX	2500	1795	3315	1260	1800
		3000	2045	3815	1510	1900
		3300	2195	4115	1660	1960
MRS15FD	DUPLEX	2500	1795	3310	1260	1900
		3000	2045	3810	1510	2000
		3300	2195	4110	1660	2060
MRS20D	DUPLEX	2500	1790	3455	/	2036
		3000	2040	3955		2146
		3300	2190	4255		2200
		3500	2290	4455		2246
		4000	2545	4810		2256
MRS15T	TRIPLEX	3700	1798	4510	1262	2065
		4000	1898	4810	1362	2080
		4300	1998	5110	1462	2095
		4500	2065	5310	1530	2105
		4800	2165	5610	1630	2120
		5000	2230	5810	1696	2130
MRS20T	TRIPLEX	3700	1798	4510	1262	2230
		4000	1898	4810	1362	2260
		4300	1998	5110	1462	2300
		4500	2065	5310	1530	2330
		4800	2165	5610	1630	2330
5000	2230	5810	1696	2360		

# OPTIONS

OPTIONS		
OPTIONS	MRS SERIES	
1	Fork length	●1070
2	Fork width	●200~800
3	Battery capacity	24V ● 210 / ○270 / ○340AH
4	Platform	○
5	Protection Arm	○
6	Moonwalk- AC & EPS model	○
7	Remote control-for lifting/lowering	○
8	Warning light	○
9	Up-right Drive	○
10	Turtle Speed	○
11	Beeper	○
12	Side Shift	○

Note: ● standard ○ option