

Hyperbaric Oxygen Chamber

(Square Cabin Style)

Model: uDR C3W+



About Hyperbaric Oxygen Therapy (HBOT) :

Hyperbaric oxygen therapy (HBOT) is well known for treating scuba and deep-sea divers affected by the rapid change in pressure around them. But did you know that HBOT is also used to treat a variety of other health problems, including carbon monoxide poisoning and diabetic foot ulcers.

Hyperbaric oxygen therapy treats chronic wounds and other medical conditions. Room air contains 21% oxygen, while hyperbaric oxygen therapy provides you with air that contains 100% oxygen. A pressurized chamber delivers oxygen that's two to three times higher than normal air pressure, which helps your lungs gather and absorb more oxygen. Oxygen helps the tissues in your body heal and withstand infections.

Healthcare providers use hyperbaric oxygen therapy alone or with other medical treatments, such as medications or surgery. Most people receive hyperbaric oxygen therapy on an outpatient basis for one to two hours each session. Depending on the type of treatment, you may sit or lie down during the procedure.

Other names for hyperbaric oxygen therapy include HBO therapy or HBOT

Features:

- 1). Big windows in front of chamber , Good line of sight and easy to observe the situation inside the cabin.
- 2). The interior space is spacious without feeling oppressive, suitable for claustrophobic users.
- 3) . The cabin is firm and can be decorated according to your own preferences.
- 4) . Interphone system for two-way communication.
- 5) . Automatic air pressure control system, the door is sealed by pressure.
- 6) . Control system combines of air compressor, oxygen concentrator.
- 7) . Security measures: With Manual safety valve and automatic safety valve,
- 8) . Delivers 96%±3% oxygen under pressure via an oxygen headset/facial mask.
- 9) . Material safety and environmental: protection Stainless Steel Material.
- 10) . ODM & OEM: Customize color for different request.

Specification:

About Cabin:

Index	Content
Model Name	uDR H3W+
Control System	In-cabin touch screen UI
Cabin Material	Double-layer metal composite material + interior soft decoration
Door Material	Special explosion-proof glass
Cabin size	1400mm(L)*800mm(W)*1882mm(H)
Cabin configuration	As the list below
Diffuse oxygen concentration	≤30%
Working pressure in the cabin	100-250KPa adjustable
Working noise	<30db
Temperature in the cabin	Ambient temperature +3°C (without air conditioner)
Safety Facilities	Manual safety valve, automatic safety valve
Floor area	1.12 m ²
Cabin weight	1060kg
Floor pressure	401.5kg/m ²

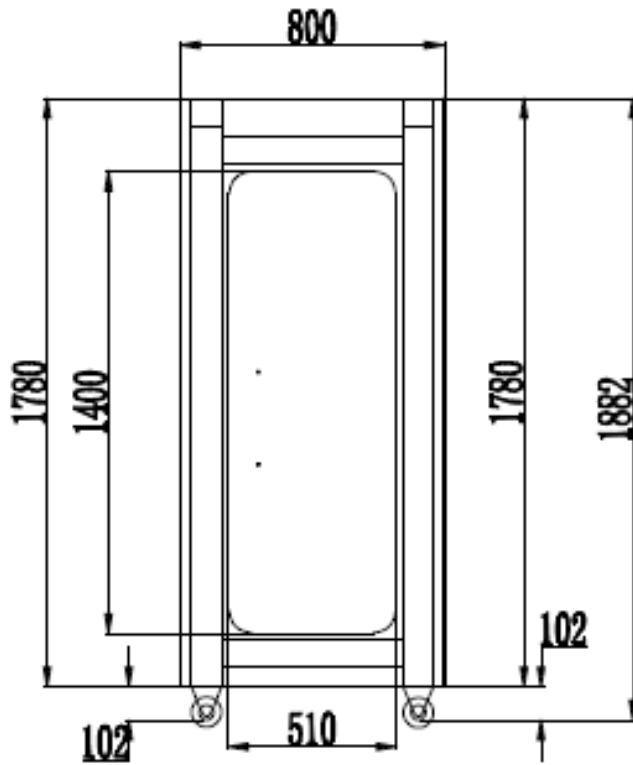
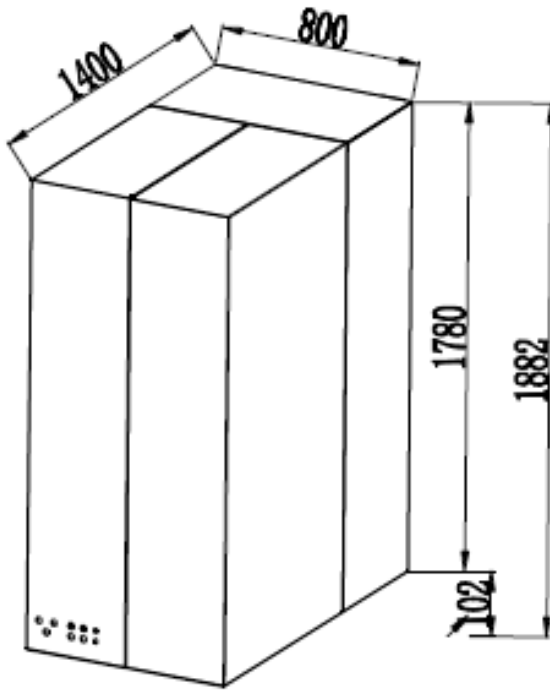

About Oxygen Supply System:

Model	uMR 07+ (default model, it can upgrade to other model)
Size	H902*L520*W570mm
Control System	Touch screen control(10 inch)
Power Supply	AC 100V-240V 50/60Hz
Power	800W
Oxygen Pipe Diameter	8 mm
Air Pipe Diameter	12 mm
Oxygen flow	10L/min
Max airflow	220 L/min
Max Outlet pressure	150KPA(1.5ATA)
Oxygen Purity	96%±3%
Oxygen system	air filter (PSA)
Compressor	Oil-free compressor air delivery system
Noise	≤45db

Appearance:

UI Interface:

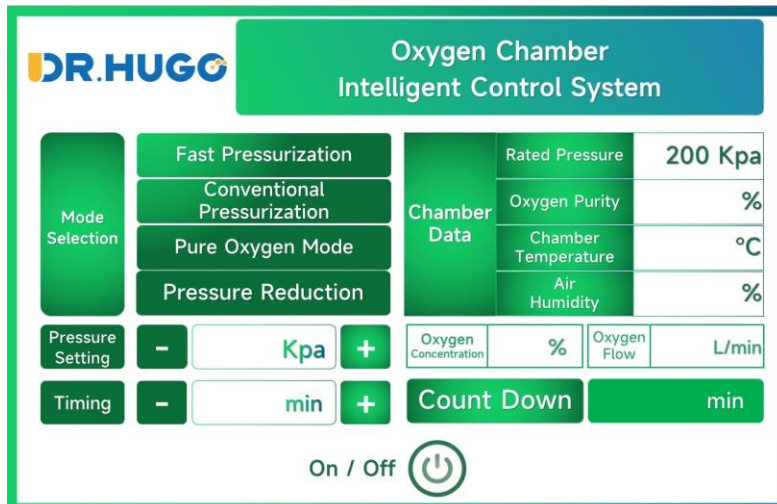

In-chamber control panel:



Configuration List:

Index	Specification	Unit	QTY
Cabin Style Chamber	1400mm(L)*800mm(W)*1882mm(H)	set	1
Oxygen Supply System	Model: uMR O7+	set	1
In-cabin controller (touch screen version)	Standard: integrated pressure, oxygen concentration, temperature And can be customize	set	1
Communication System	Internal and external, Dual wireless, Chargeable	set	1
Oxygen Terminal Connector	Medical grade self-locking (national standard)	set	1
Humidification Bottle	Medical grade with regulating valve (national standard)	set	1
Automatic Safety Relief Valve	3.5Psi/4.5Psi/Customize	set	2
Emergency Relief Valve	customize	set	1
Interior Decoration	Bamboo wood fiber, PU leather	set	1
Carpet	Customize /Middle fleece/Light color	set	1
Illumination	LED (light color optional) warm white/bright white/ice blue	set	1
Sofa	Sofa (non-adjustable/PU leather/compact)	set	2
In-cabin Power Supply System	Optional: 12/24V(double voltage) 600W	set	1
Air conditioner for oxygen chamber	Optional : Water-cool air conditioner /500W	set	1
Massage Chair	Optional: 24V / 120W	set	1
DC TV	Optional: 24V / 100W	set	1



DR.HUGO

Your Oxygen Therapy Expert

POWER BY:



LANNX Bio&Med Co.,Ltd

Website: www.lannx.net/hbot/

E-Mail: sale@lannx.net

-Search our channel in YouTube to view operation video:

<https://www.youtube.com/@oxygensupplycenter>