



## TECHNICAL SPECIFICATION

### DRUK-12(B) UNDERGROUND TRUCK



The UK- 12 short-wheelbase underground haul truck is designed primarily for transporting blasted loose material in mine operations. It is also well-suited for railway, highway, and water-conservancy tunnel projects, especially in harsh working environments characterized by confined spaces, low headroom, and muddy or uneven ground conditions.

<b>Main Technical Parameters of the Complete Machine</b>			
No.	Parameter Description	Front Hoist Baffle	Without a front hoist baffle
1	Rated Bucket Capacity (m <sup>3</sup> )	5.5	6
2	Rated Payload (kg)	12000	11000
3	Operating Weight, Empty (kg)	15700	15200
4	Overall Dimensions (L × W × H) (mm)	7533x2140x2281	7480x2140x2281

5	Loading Height (mm)	1970	
6	Body Lift Height (mm)	4065	
7	Body Dump Angle ( ° )	68	
8	Body Lift Time (s)	15	
9	Maximum Traction Force (kN)	≥165	
10	Ground Clearance (mm)	289	
11	Approach Angle ( ° )	15	
12	Oscillation Angle ( ° )	±8	
13	Gradability ( ° )	≥14	
14	Minimum Turning Radius (mm)	Inside wheel:3611 Outside wheel:6219	
15	Travel Speed(km/h)	1gear	4.5
		2gear	8.9
		3gear	14.9
		4gear	25.7

**Front View** (Without a front hoist baffle)

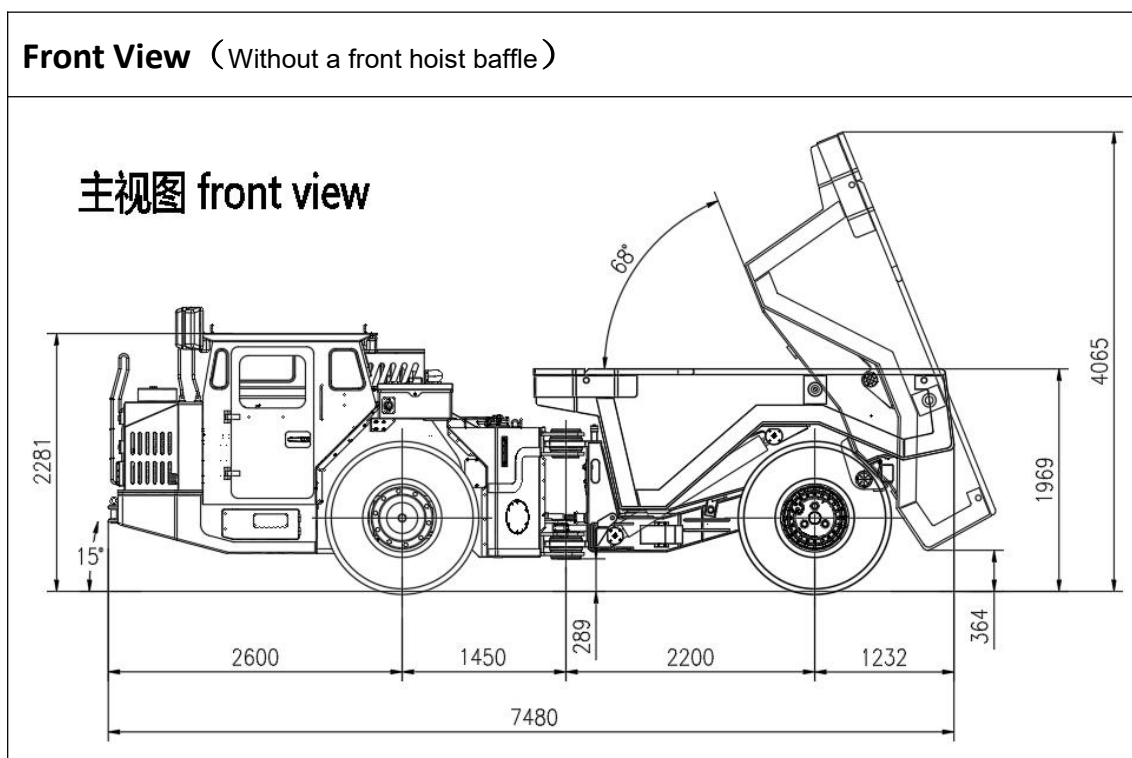

Front View (Front Hoist Baffle)

主视图 front view

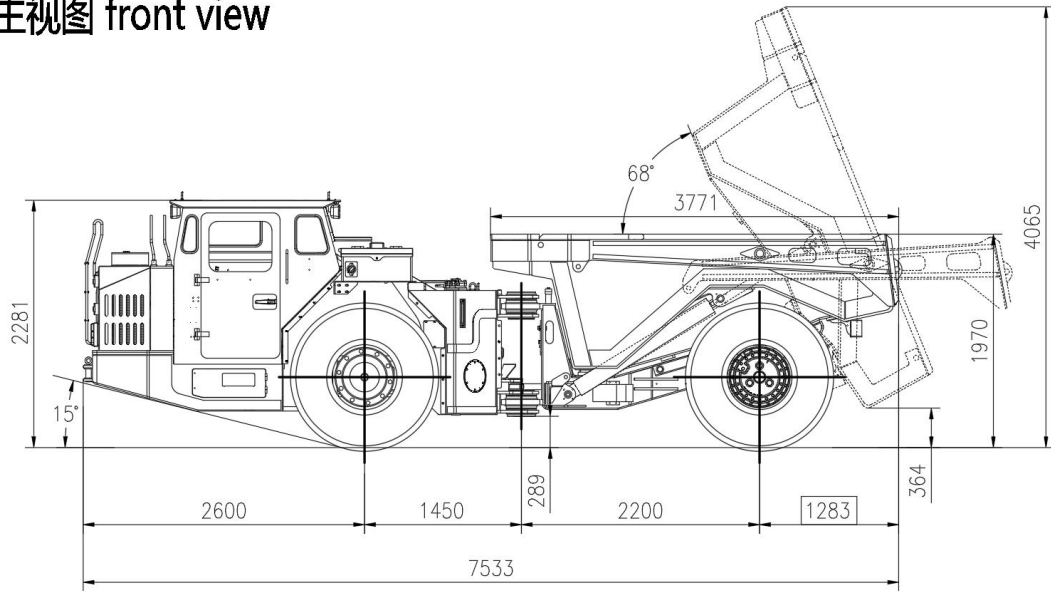

Steering View

转向巷道图 Steering view

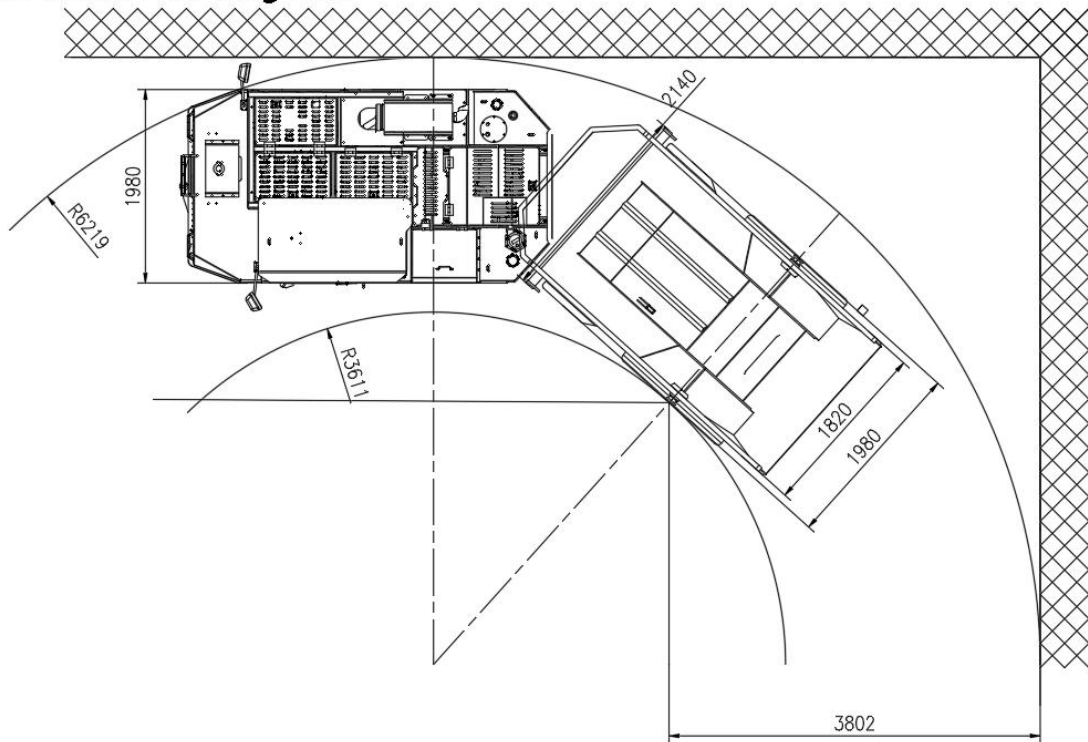

## Main Benefits

**Productivity-** The DRUK- 12 features heavy- duty front and rear frames specifically engineered to withstand harsh underground conditions. With outstanding quality, reliability, and durability that meet user demands, it makes transport operations simpler, more effective, and more efficient.

**Safety-**The power system of this machine is equipped with a Cummins engine, complemented by an exhaust silencer and purifier that deliver noticeable purification effects, effectively reducing air pollution and improving the underground working environment.

The braking system employs spring- applied, hydraulically- released brakes, which enhance safety performance and ensure reliable operation in harsh, high- moisture, and muddy tunnel conditions.

The forward- positioned, front- mounted cab provides a highly comfortable operating environment without compromising the operator's field of vision.



<b>Engine</b>	
Brand/Model	Cummins QSB4.5
Rated Power	119kw
Cooling Method	Water Cooling
Emission Standed	China III

<b>Fuel</b>	Litres
Working Hydraulic Oil Tank	200
Travel Hydraulic Oil Tank	200

<b>Hydraulic System</b>	<b>Brand</b>	
Working Pump(Gear Pump)	Parmco/WANY	√
Steering Pump(Gear Pump)	Parmco/WANY	√
Multi - way Control Valve	Walvoil/Youli	√
Steering Control Valve	Danfoss	√
Make - up Valve / Replenishing Valve	Mico/NAVNIX/Yuxin Technology	√
Pedal Valve	Mico/NAVNIX/Yuxin Technology	√

<b>Electric system</b>	
Working Voltage,24V	√
4.5-inch Color Display Screen	√
Real-time Monitoring of Operating Status of Main System Components	√
CAN Bus Communication	√

<b>Transmission</b>		
Torque Converter	DANA C270/ Shantui YJ340	√
Gearbox / Transmission	DANA R32000/ NDNANCE YD13	√
Drive Axle	Shandong Derui	√
Tyre / Tire	14.00-24	√

<b>Main frame</b>	
Fire extinguisher	√
Backup Camera System	√

<b>Control system</b>	
Engine Data Display	√
Audible Backup Alarm	√
Audible Dump Alarm	√
Steering Wheel Control	√
Single- lever Dump and Lift Control	√

<b>Operator's Compartment</b>	
Canopy(ISO ROPS and FOPS approved)	√
Standard Semi-enclosed Cab	√
LED Front and Rear Lighting	√
Two - Point Seat Belt	√
Three - Point Contact Quick Access to Cab	√
Mechanical Suspension Seat	√
Steering Wheel Control	√
Door Interlock Protection	√

<b>Documentation</b>	
Parts manual	√
Operational manual	√
Maintenance and service manual	√

<b>Optional Configurations</b>
Automatic Fire Suppression System
Fully Enclosed Cab with Heating and Air Conditioning
Automatic Centralized Lubrication System
Hopper Baffle / Bucket Baffle