

BT.1001 BRASS BALL VALVE

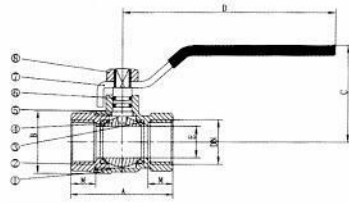
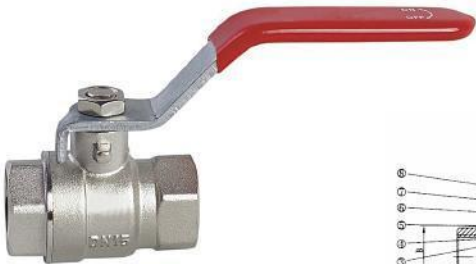

NO	PART	MATERIAL
1	BODY	BRASS
2	BONNET	BRASS
3	BALL SEAT	PTFE
4	BALL	BRASS
5	STEM	BRASS
6	*O*RING	NBR
7	HANDLE	STEEL
8	NUT	STEEL

SIZE	1/4"	3/8"	1/2"	3/4"	1"	1*1/4"	1*1/2"	2"	2*1/2"	3"	4"
A	43	43	50	56	65	76	85	99	132	152	178
B	23	23	29.5	35	42.7	53	63	79	102.5	120.5	144.5
C	39.2	39.8	54.2	57.6	60.6	75.8	81.3	88.5	121.5	129.5	141
D	87	87	95	95	126	140	140	165	224	224	283.5
DN	9	10	14.8	19	24	30.2	37	47	74	74	90

BT.1002 BRASS BALL VALVE

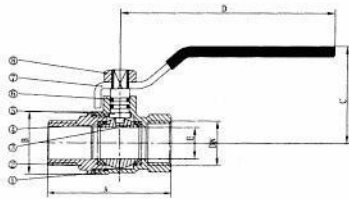

NO	PART	MATERIAL
1	BODY	BRASS
2	BONNET	BRASS
3	BALL SEAT	PTFE
4	BALL	BRASS
5	STEM	BRASS
6	*O*RING	NBR
7	HANDLE	STEEL
8	NUT	STEEL

SIZE	1/4"	3/8"	1/2"	3/4"	1"	1*1/4"	1*1/2"	2"	2*1/2"	3"	4"
A	48.5	50	57.5	63.8	74.5	87	98	113.5			
B	23	23	29.5	35	42.7	53	63	79			
C	39.2	39.8	54.2	57.6	60.6	75.8	81.3	88.5			
D	87	87	95	95	126	140	140	165			
DN	9	10	14.8	19	24	30.2	37	47			

BT.1003 BRASS BALL VALVE

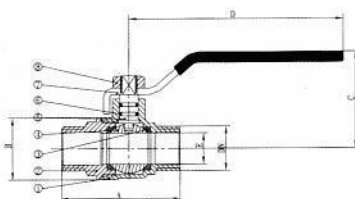

NO	PART	MATERIAL
1	BODY	BRASS
2	BONNET	BRASS
3	BALL SEAT	PTFE
4	BALL	BRASS
5	STEM	BRASS
6	*O*RING	NBR
7	HANDLE	STEEL
8	NUT	STEEL

SIZE	1/4"	3/8"	1/2"	3/4"	1"	1*1/4"	1*1/2"	2"	2*1/2"	3"	4"
A			59.2	65.8	77.5						
B			29.5	35	42.7						
C			54.2	57.6	60.6						
D			95	95	126						
DN			14.8	19	24						

BT.1004 BRASS BALL VALVE

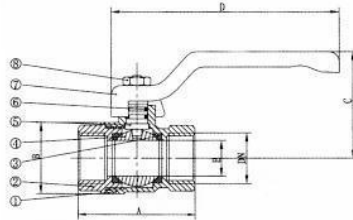

NO	PART	MATERIAL
1	BODY	BRASS
2	BONNET	BRASS
3	BALL SEAT	PTFE
4	BALL	BRASS
5	STEM	BRASS
6	*O*RING	NBR
7	HANDLE	STEEL
8	NUT	STEEL

SIZE	1/4"	3/8"	1/2"	3/4"	1"	1 1/4"	1 1/2"	2"	2 1/2"	3"	4"
A	43	43	50	56	65	76	85	99	132	152	178
B	23	23	29.5	35	42.7	53	63	79	102.5	120.5	144.5
C	39.2	39.8	54.2	57.6	60.6	75.8	81.3	88.5	121.5	129.5	141
D	87	87	95	95	126	140	140	165	224	224	283.5
DN	9	10	14.8	19	24	30.2	37	47	74	74	90

BT.1005 BRASS BALL VALVE

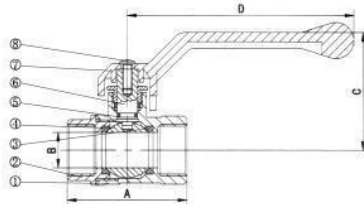

NO	PART	MATERIAL
1	BODY	BRASS
2	BONNET	BRASS
3	BALL SEAT	PTFE
4	BALL	BRASS
5	STEM	BRASS
6	*O*RING	NBR
7	HANDLE	ALUMINIUM
8	NUT	STEEL

SIZE	1/4"	3/8"	1/2"	3/4"	1"	1 1/4"	1 1/2"	2"	2 1/2"	3"	4"
A	43	43	50	56	65	76	85	99	132	152	178
B	23	23	29.5	35	42.7	53	63	79	102.5	120.5	144.5
C	39.2	39.8	54.2	57.6	60.6	75.8	81.3	88.5	121.5	129.5	141
D	87	87	95	95	126	140	140	165	224	224	283.5
DN	9	10	14.8	19	24	30.2	37	47	74	74	90

BT.1006 BRASS BALL VALVE

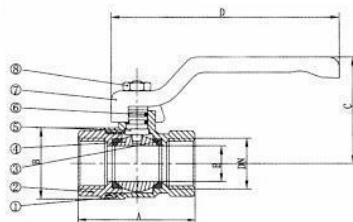

NO	PART	MATERIAL
1	BODY	BRASS
2	BONNET	BRASS
3	BALL SEAT	PTFE
4	BALL	BRASS
5	STEM	BRASS
6	*O*RING	NBR
7	HANDLE	ALUMINIUM
8	NUT	STEEL

SIZE	1/4"	3/8"	1/2"	3/4"	1"	1 1/4"	1 1/2"	2"	2 1/2"	3"	4"
A	43	43	48.4	56	65	76	85	99	132	152	178
B	23	23	29.5	35	42.7	53	63	79	102.5	120.5	144.5
C	39.2	39.8	54.2	57.6	60.6	75.8	81.3	88.5	121.5	129.5	141
D	87	87	95	95	126	140	140	165	224	224	283.5
DN	9	10	14.8	19	24	30.2	37	47	74	74	90

BT.1007 BRASS BALL VALVE

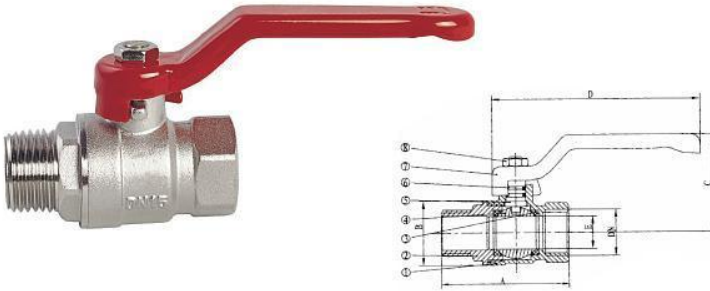

NO	PART	MATERIAL
1	BODY	BRASS
2	BONNET	BRASS
3	BALL SEAT	PTFE
4	BALL	BRASS
5	STEM	BRASS
6	*O*RING	NBR
7	HANDLE	STEEL
8	NUT	STEEL

SIZE	1/4"	3/8"	1/2"	3/4"	1"	1*1/4"	1*1/2"	2"	2*1/2"	3"	4"
A	48.5	50	57.5	63.8	74.5	87	98	113.5			
B	23	23	29.5	35	42.7	53	63	79			
C	39.2	39.8	54.2	57.6	60.6	75.8	81.3	88.5			
D	87	87	95	95	126	140	140	165			
DN	9	10	14.8	19	24	30.2	37	47			

BT.1008 BRASS BALL VALVE

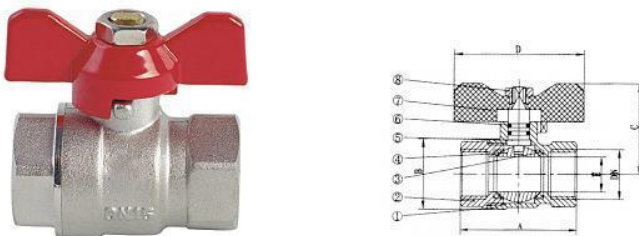

NO	PART	MATERIAL
1	BODY	BRASS
2	BONNET	BRASS
3	BALL SEAT	PTFE
4	BALL	BRASS
5	STEM	BRASS
6	*O*RING	NBR
7	BUTTERFLY HANDLE	ALUMINIUM
8	NUT	STEEL

SIZE	1/4"	3/8"	1/2"	3/4"	1"	1*1/4"	1*1/2"	2"	2*1/2"	3"	4"
A	43	43	48.4	56	65	76	85	99			
B	23	23	29.5	35	42.7	53	63	79			
C	35	36	38.8	42.2	50	60	66.5	75			
D	54	54	54	54	62	75	75	85			
DN	9	10	14.8	19	24	30.2	37	47			

BT.1009 BRASS BALL VALVE

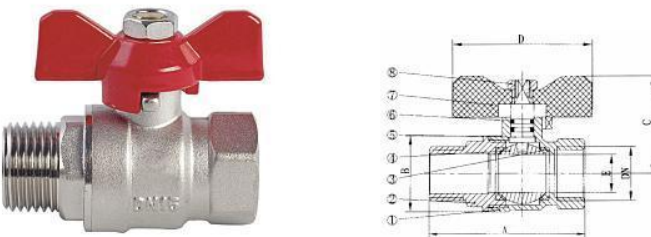

NO	PART	MATERIAL
1	BODY	BRASS
2	BONNET	BRASS
3	BALL SEAT	PTFE
4	BALL	BRASS
5	STEM	BRASS
6	*O*RING	NBR
7	BUTTERFLY HANDLE	ALUMINIUM
8	NUT	STEEL

SIZE	1/4"	3/8"	1/2"	3/4"	1"	1*1/4"	1*1/2"	2"	2*1/2"	3"	4"
A	48.5	50	57.5	63.8	74.5	87	98	113.5			
B	23	23	29.5	35	42.7	53	63	79			
C	35	36	38.8	42.2	50	60	66.5	75			
D	54	54	54	54	62	75	75	85			
DN	9	10	14.8	19	24	30.2	37	47			

BT.1010 BRASS BALL VALVE

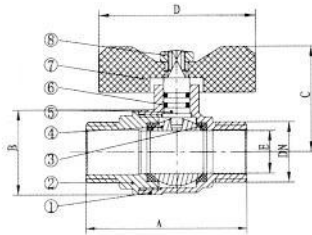

NO	PART	MATERIAL
1	BODY	BRASS
2	BONNET	BRASS
3	BALL SEAT	PTFE
4	BALL	BRASS
5	STEM	BRASS
6	*O*RING	NBR
7	BUTTERFLY HANDLE	ALUMINIUM
8	NUT	STEEL

SIZE	1/4"	3/8"	1/2"	3/4"	1"	1*1/4"	1*1/2"	2"	2*1/2"	3"	4"
A			59.2	65.8	77.5						
B			29.5	35	42.7						
C			38.8	42.2	50						
D			54	54	62						
DN			14.8	19	24						

BT.1011 BRASS BALL VALVE

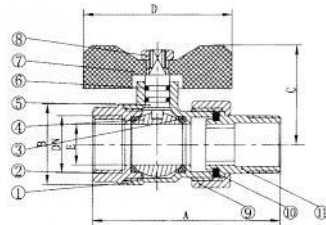

NO	PART	MATERIAL
1	BODY	BRASS
2	BONNET	BRASS
3	BALL SEAT	PTFE
4	BALL	BRASS
5	STEM	BRASS
6	*O*RING	NBR
7	BUTTERFLY HANDLE	ALUMINIUM
8	NUT	STEEL
9	RING	BRASS
10	GASKET	NBR
11	UNION	BRASS

SIZE	1/4"	3/8"	1/2"	3/4"	1"	1*1/4"	1*1/2"	2"	2*1/2"	3"	4"
A			68	78	91	106					
B			29.5	35	42.7	53					
C			38.8	42.2	50	60					
D			54	54	62	75					
DN			14.8	19	24	30.2					

BT.1012 BRASS BALL VALVE

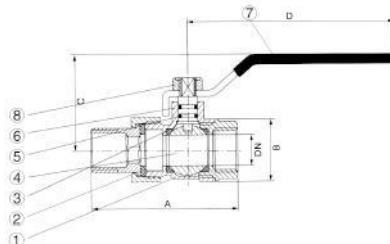

NO	PART	MATERIAL
1	BODY	BRASS
2	BONNET	BRASS
3	BALL SEAT	PTFE
4	BALL	BRASS
5	STEM	BRASS
6	*O*RING	NBR
7	HANDLE	STEEL
8	NUT	STEEL

SIZE	1/4"	3/8"	1/2"	3/4"	1"	1*1/4"	1*1/2"	2"	2*1/2"	3"	4"
A			68	78	91	106					
B			29.5	35	42.7	53					
C			54.2	57.6	60.6	75.8					
D			95	95	126	140					
DN			14.8	19	24	30.2					

BT.1013 BRASS BALL VALVE

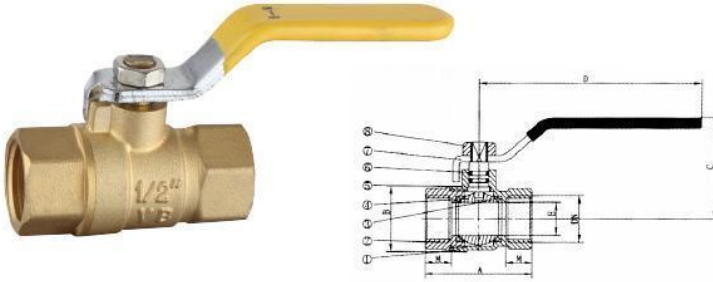

NO	PART	MATERIAL
1	BODY	BRASS
2	BONNET	BRASS
3	BALL SEAT	PTFE
4	BALL	BRASS
5	STEM	BRASS
6	*O*RING	NBR
7	HANDLE	STEEL
8	NUT	STEEL

SIZE	1/4"	3/8"	1/2"	3/4"	1"	1 1/4"	1 1/2"	2"	2 1/2"	3"	4"
A	43	43	55	61.4	67.6	78	88	103	132	152	178
B	23	23	29	35.5	43	53	62.5	79	102.5	120.5	144.5
C	39.2	39.8	57	60	62	80	85	94	121.5	129.5	141
D	87	87	95	95	126	140	140	165	224	224	283.5
DN	9	10	13	18	23	29.2	36	45.5	62	74	90

BT.1014 BRASS BALL VALVE

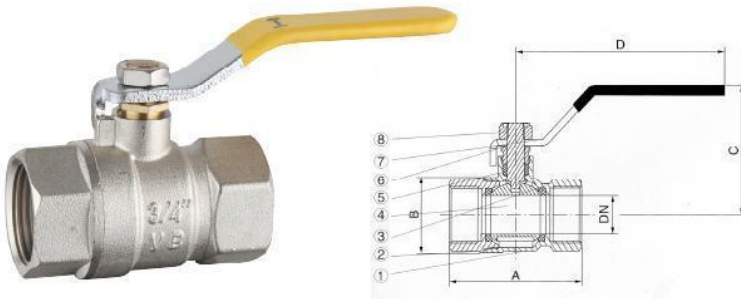

NO	PART	MATERIAL
1	BODY	BRASS
2	BONNET	BRASS
3	BALL SEAT	PTFE
4	BALL	BRASS
5	STEM	BRASS
6	PRESS NUT	BRASS
7	HANDLE	STEEL
8	NUT	STEEL

SIZE	1/4"	3/8"	1/2"	3/4"	1"	1 1/4"	1 1/2"	2"	2 1/2"	3"	4"
A	43	43	55	61.4	67.6	78	88	103	132	152	178
B	23	23	29	35.5	43	53	62.5	79	102.5	120.5	144.5
C	39.2	39.8	57	60	62	80	85	94	121.5	129.5	141
D	87	87	95	95	126	140	140	165	224	224	283.5
DN	9	10	13	18	23	29.2	36	45.5	62	74	90

BT.1015 BRASS BALL VALVE

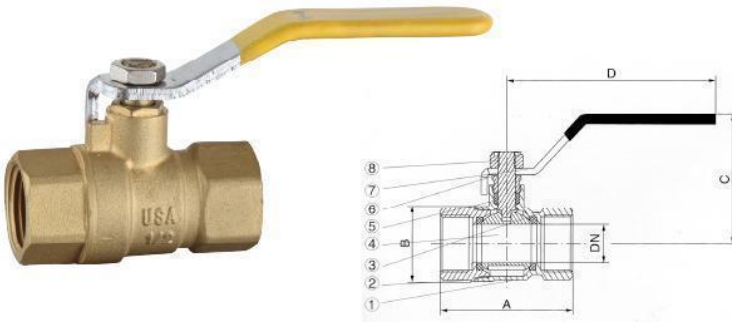

NO	PART	MATERIAL
1	BODY	BRASS
2	BONNET	BRASS
3	BALL SEAT	PTFE
4	BALL	BRASS
5	STEM	BRASS
6	*O*RING	NBR
7	HANDLE	STEEL
8	NUT	STEEL

SIZE	1/4"	3/8"	1/2"	3/4"	1"	1 1/4"	1 1/2"	2"	2 1/2"	3"	4"
A	43	43	55	61.4	67.6	78	88	103	132	152	178
B	23	23	29	35.5	43	53	62.5	79	102.5	120.5	144.5
C	39.2	39.8	57	60	62	80	85	94	121.5	129.5	141
D	87	87	95	95	126	140	140	165	224	224	283.5
DN	9	10	13	18	23	29.2	36	45.5	62	74	90

BT.1016 BRASS BALL VALVE

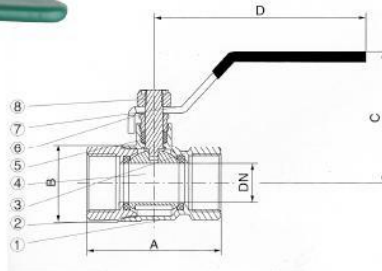

NO	PART	MATERIAL
1	BODY	BRASS
2	BONNET	BRASS
3	BALL SEAT	PTFE
4	BALL	BRASS
5	STEM	BRASS
6	*O*RING	NBR
7	HANDLE	STEEL
8	NUT	STEEL

SIZE	1/4"	3/8"	1/2"	3/4"	1"	1*1/4"	1*1/2"	2"	2*1/2"	3"	4"
A	43	43	55	61.4	67.6	78	88	103	132	152	178
B	23	23	29	35.5	43	53	62.5	79	102.5	120.5	144.5
C	39.2	39.8	57	60	62	80	85	94	121.5	129.5	141
D	87	87	95	95	126	140	140	165	224	224	283.5
DN	9	10	13	18	23	29.2	36	45.5	62	74	90

BT.1017 BRASS BALL VALVE

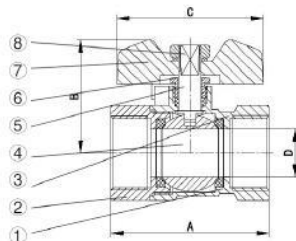

NO	PART	MATERIAL
1	BODY	BRASS
2	BONNET	BRASS
3	BALL SEAT	PTFE
4	BALL	BRASS
5	STEM	BRASS
6	PRESS NUT	BRASS
7	HANDLE	ALUMINUM HANDLE
8	NUT	STEEL

SIZE	1/4"	3/8"	1/2"	3/4"	1"	1*1/4"	1*1/2"	2"	2*1/2"	3"	4"
A	43	43	55	61.4	68						
B	41	41	43	47	51						
C	40	40	45	45	51.5						
D	8	10	13.5	17	22.5						
DN	8	10	15	20	25						

BT.1018 BRASS BALL VALVE

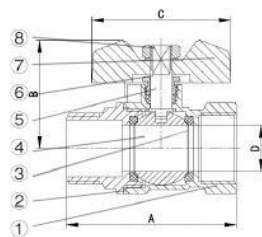

NO	PART	MATERIAL
1	BODY	BRASS
2	BONNET	BRASS
3	BALL SEAT	PTFE
4	BALL	BRASS
5	STEM	BRASS
6	PRESS NUT	BRASS
7	HANDLE	ALUMINUM
8	NUT	STEEL

SIZE	1/4"	3/8"	1/2"	3/4"	1"	1*1/4"	1*1/2"	2"	2*1/2"	3"	4"
A	43.5	52	57	62	73						
B	41	41	43	47	51						
C	40	40	45	45	51.5						
D	8	10	13.5	17	22.5						
DN	8	10	15	20	25						

BT.1019 BRASS BALL VALVE

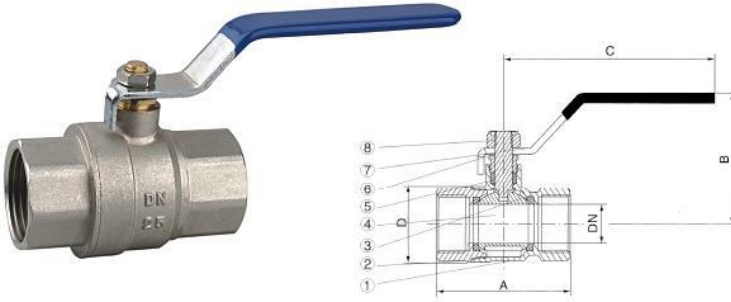

NO	PART	MATERIAL
1	BODY	BRASS
2	BONNET	BRASS
3	BALL SEAT	PTFE
4	BALL	BRASS
5	STEM	BRASS
6	PRESS NUT	BRASS
7	HANDLE	STEEL
8	NUT	STEEL

SIZE	1/4"	3/8"	1/2"	3/4"	1"	1*1/4	1*1/2	2"	2*1/2	3"	4"
A			52.5	60.5	69.5	78	91	104	123	155	178
B			46	49	58	69.5	76.5	84.5	115	132	148
C			87.5	87.5	104	136	150	150	210	210	290
D			15	20	25	32	37	47	57	68	84
DN			15	20	25	32	40	50	65	80	100

BT.1020 BRASS BALL VALVE

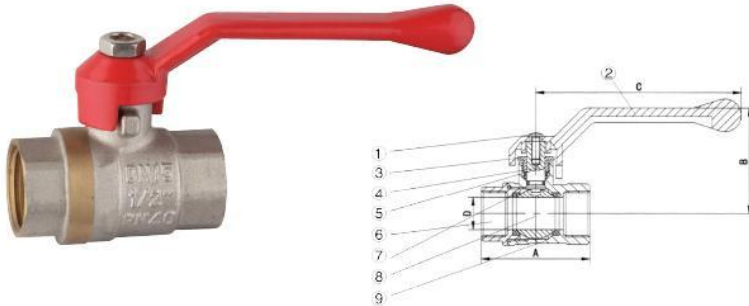

NO	PART	MATERIAL
1	NUT	STEEL
2	HANDLE	ALUMINUM
3	PRESS NUT	BRASS
4	STEM	BRASS
5	GASKET	PTFE
6	BONNET	BRASS
7	SEAT	PTFE
8	BALL	BRASS
9	BODY	BRASS

SIZE	1/4"	3/8"	1/2"	3/4"	1"	1*1/4	1*1/2	2"	2*1/2	3"	4"
A			47	55	64	75	88	100	120	148	171
B			45	48	56	70	75	87	113	130	145
C			85	85	103	120	120	150	215	215	295
D			14	19	23	30	38	47	57	69	85
DN			15	20	25	32	40	50	65	80	100

BT.1021 BRASS BALL VALVE

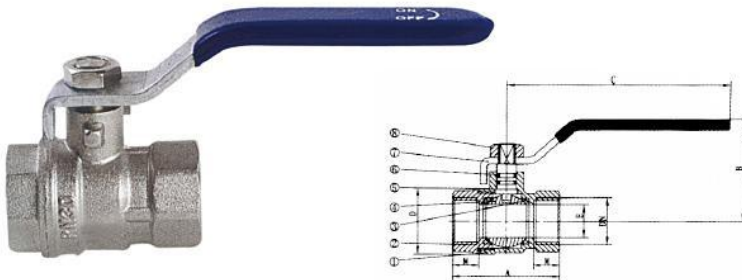

NO	PART	MATERIAL
1	BODY	BRASS
2	BONNET	BRASS
3	BALL SEAT	PTFE
4	BALL	BRASS
5	STEM	BRASS
6	*O*RING	NBR
7	HANDLE	STEEL
8	NUT	STEEL

SIZE	1/4"	3/8"	1/2"	3/4"	1"	1*1/4	1*1/2	2"	2*1/2	3"	4"
A	43	43	47	54	64	72	88.5	101	112	135	152
B	23	23	50	60	68	78	83	97	110	127	138
C	39.2	39.8	93	93	111.5	137	137	165	210	210	288
D	87	87	14	17	22	29	37	44	55	67	82
DN	9	10	15	20	25	32	40	50	65	80	100

BT.1022 BRASS BALL VALVE

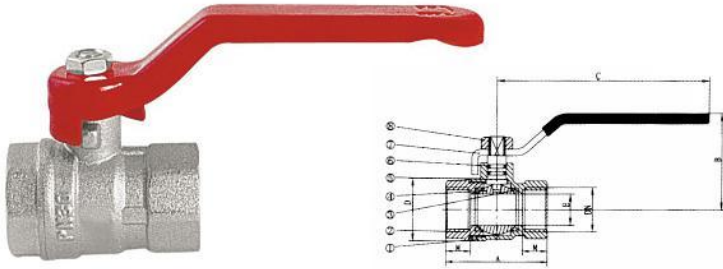

NO	PART	MATERIAL
1	BODY	BRASS
2	BONNET	BRASS
3	BALL SEAT	PTFE
4	BALL	BRASS
5	STEM	BRASS
6	*O*RING	NBR
7	HANDLE	STEEL
8	NUT	STEEL

SIZE	1/4"	3/8"	1/2"	3/4"	1"	1 1/4"	1 1/2"	2"	2 1/2"	3"	4"
A			47	54	64	72	88.5	101	112	135	152
B			50	60	68	78	83	97	110	127	138
C			93	93	111.5	137	137	165	210	210	288
D			14	17	22	29	37	44	55	67	82
DN			15	20	25	32	40	50	65	80	100

BT.1023 BRASS BALL VALVE

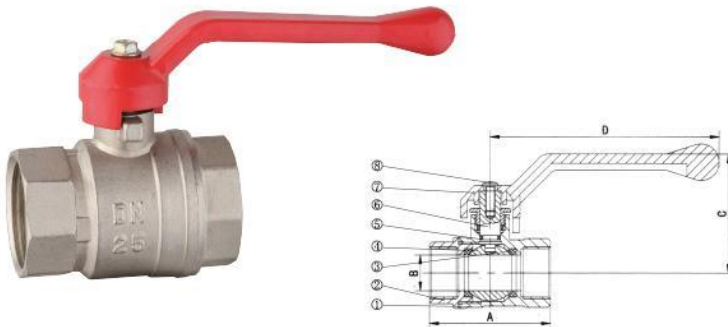

NO	PART	MATERIAL
1	BODY	BRASS
2	BONNET	BRASS
3	BALL SEAT	PTFE
4	BALL	BRASS
5	STEM	BRASS
6	*O*RING	NBR
7	HANDLE	ALUMINUM
8	NUT	STEEL

SIZE	1/4"	3/8"	1/2"	3/4"	1"	1 1/4"	1 1/2"	2"	2 1/2"	3"	4"
A			47	54	64	72	88.5	101	112	135	152
B			50	60	68	78	83	97	110	127	138
C			93	93	111.5	137	137	165	210	210	288
D			14	17	22	29	37	44	55	67	82
DN			15	20	25	32	40	50	65	80	100

BT.1024 BRASS BALL VALVE

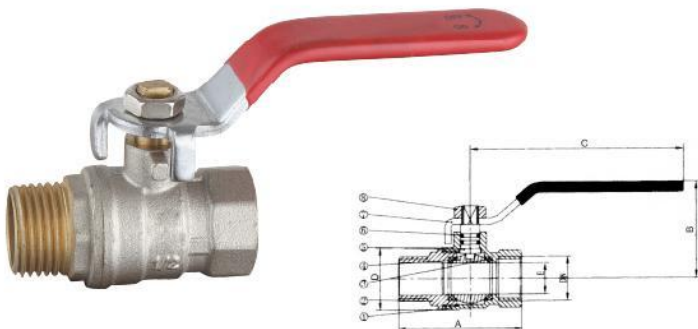

NO	PART	MATERIAL
1	BODY	BRASS
2	BONNET	BRASS
3	BALL SEAT	PTFE
4	BALL	BRASS
5	STEM	BRASS
6	*O*RING	NBR
7	HANDLE	STEEL
8	NUT	STEEL

SIZE	1/4"	3/8"	1/2"	3/4"	1"	1 1/4"	1 1/2"	2"	2 1/2"	3"	4"
A			55	65.5	70	78.5					
B			50	60	68	78					
C			93	93	111.5	130					
D			14	17	22	29					
DN			15	20	25	32					

BT.1025 BRASS BALL VALVE

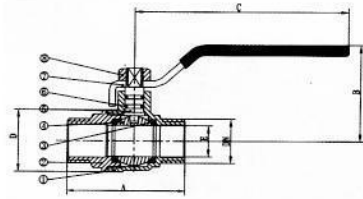

NO	PART	MATERIAL
1	BODY	BRASS
2	BONNET	BRASS
3	BALL SEAT	PTFE
4	BALL	BRASS
5	STEM	BRASS
6	*O*RING	NBR
7	HANDLE	STEEL
8	NUT	STEEL

SIZE	1/4"	3/8"	1/2"	3/4"	1"	1 1/4"	1 1/2"	2"	2 1/2"	3"	4"
A			55	60.5	70						
B			50	60	68						
C			93	93	111.5						
D			14	17	22						
DN			15	20	25						

BT.1026 BRASS BALL VALVE

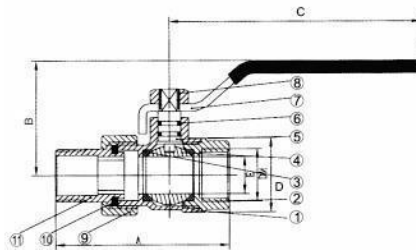

NO	PART	MATERIAL
1	BODY	BRASS
2	BONNET	BRASS
3	BALL SEAT	PTFE
4	BALL	BRASS
5	STEM	BRASS
6	"O" RING	NBR
7	HANDLE	STEEL
8	NUT	STEEL
9	RING	BRASS
10	GASKET	NBR
11	UNION	BRASS

SIZE	1/4"	3/8"	1/2"	3/4"	1"	1 1/4"	1 1/2"	2"	2 1/2"	3"	4"
A			72	85	101						
B			50	60	68						
C			93	93	111.5						
D			14	17	22						
DN			15	20	25						

BT.1027 BRASS BALL VALVE

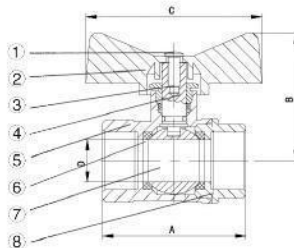

NO	PART	MATERIAL
1	NUT	STEEL
2	HANDLE	AL
3	STEM	BRASS
4	*O*RING	NBR
5	BONNET	BRASS
6	SEAT	PTFE
7	BALL	BRASS
8	BODY	BRASS

SIZE	1/4"	3/8"	1/2"	3/4"	1"	1 1/4"	1 1/2"	2"	2 1/2"	3"	4"
A			47	63	68						
B			42	45	54.5						
C			51	51	62						
D			14	17	22						
DN			15	20	25						

BT.1028 BRASS BALL VALVE

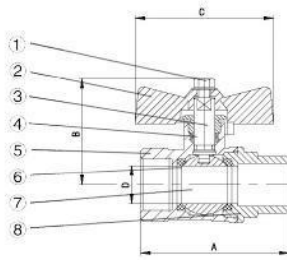

NO	PART	MATERIAL
1	NUT	STEEL
2	HANDLE	AL
3	STEM	BRASS
4	*O*RING	NBR
5	BONNET	BRASS
6	SEAT	PTFE
7	BALL	BRASS
8	BODY	BRASS

SIZE	1/4"	3/8"	1/2"	3/4"	1"	1 1/4"	1 1/2"	2"	2 1/2"	3"	4"
A			55	65.5	70						
B			39	42	54.5						
C			51	51	62						
D			14	17	22						
DN			15	20	25						

BT.1029 BRASS BALL VALVE

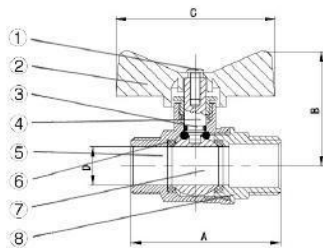

NO	PART	MATERIAL
1	NUT	STEEL
2	HANDLE	AL
3	STEM	BRASS
4	*O*RING	NBR
5	BONNET	BRASS
6	SEAT	PTFE
7	BALL	BRASS
8	BODY	BRASS

SIZE	1/4"	3/8"	1/2"	3/4"	1"	1 1/4"	1 1/2"	2"	2 1/2"	3"	4"
A			55	65.5	70						
B			42	44.5	53						
C			58	58	68						
D			14	17	22						
DN			15	20	25						

BT.1030 BRASS BALL VALVE

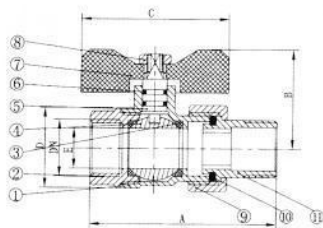

NO	PART	MATERIAL
1	BODY	BRASS
2	BONNET	BRASS
3	BALL SEAT	PTFE
4	BALL	BRASS
5	STEM	BRASS
6	*O*RING	NBR
7	BUTTERFLY HANDLE	ALUMINIUM
8	NUT	STEEL
9	RING	BRASS
10	GASKET	NBR
11	UNION	BRASS

SIZE	1/4"	3/8"	1/2"	3/4"	1"	1 1/4"	1 1/2"	2"	2 1/2"	3"	4"
A			72	85	101						
B			39	42	54.5						
C			51	51	62						
D			14	17	22						
DN			15	20	25						

BT.1031 BRASS BALL VALVE

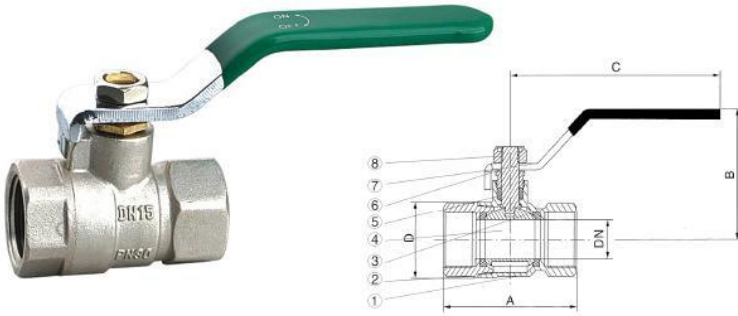

NO	PART	MATERIAL
1	BODY	BRASS
2	BONNET	BRASS
3	BALL SEAT	PTFE
4	BALL	BRASS
5	STEM	BRASS
6	PRESS NUT	BRASS
7	HANDLE	STEEL
8	NUT	STEEL

SIZE	1/4"	3/8"	1/2"	3/4"	1"	1 1/4"	1 1/2"	2"	2 1/2"	3"	4"
A	40	45	50.5	56	68	75	94.5	93.5	128	162	179
B	33	33	42	45.5	56.5	72	79	87	116	133	149
C	60	60	84.5	92	104.5	112	120	130	207	207	281
D	8	10	13.5	17	22.5	30	37	42	53	64	82
DN	8	10	15	20	25	32	40	50	65	80	100

BT.1032 BRASS BALL VALVE

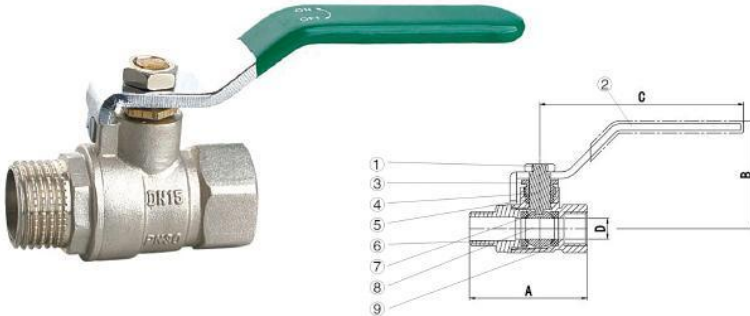

NO	PART	MATERIAL
1	NUT	STEEL
2	HANDLE	STEEL
3	PRESS NUT	BRASS
4	STEM	BRASS
5	GASKET	PTFE
6	BONNET	BRASS
7	SEAT	PTFE
8	BALL	BRASS
9	BODY	BRASS

SIZE	1/4"	3/8"	1/2"	3/4"	1"	1 1/4"	1 1/2"	2"	2 1/2"	3"	4"
A	43.5	52	57	62	73	80	98	104			
B	41.5	41.5	42	45.5	57	75	82	91			
C	78.5	78.5	84.5	92	104.5	112	120	130			
D	8	10	13.5	17	22.5	30	37	42			
DN	8	10	15	20	25	32	40	50			

BT.1033 BRASS BALL VALVE

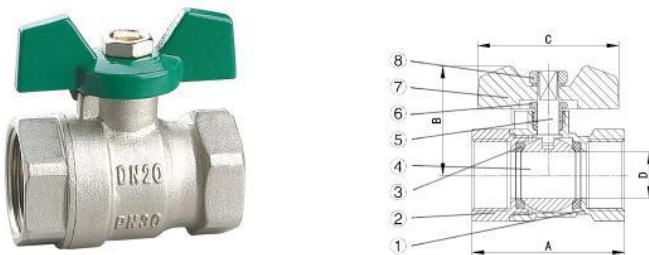

NO	PART	MATERIAL
1	BODY	BRASS
2	BONNET	BRASS
3	BALL SEAT	PTFE
4	BALL	BRASS
5	STEM	BRASS
6	PRESS NUT	BRASS
7	HANDLE	ALUMINIUM
8	NUT	STEEL

SIZE	1/4"	3/8"	1/2"	3/4"	1"	1 1/4"	1 1/2"	2"	2 1/2"	3"	4"
A	40	45	50.5	56	68						
B	41	41	43	47	51						
C	40	40	45	45	51.5						
D	8	10	13.5	17	22.5						
DN	8	10	15	20	25						

BT.1034 REDUCING BRASS VALVE

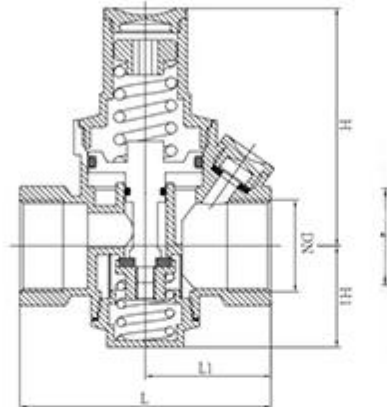

DN (mm)	SIZE (inch)	L (mm)	L1 (mm)	H (mm)
15	1/2"	66	33	67
20	3/4"	66	33	67
25	1"	79	39.5	72
32	1 1/4"	82	41	76
40	1 1/2"	100	50	98
50	2"	107	53.5	99

BT.1035 AIR BRASS VALVE

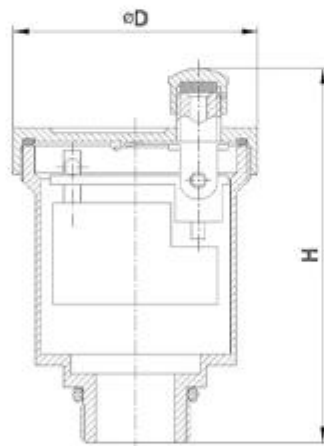

DN (mm)	SIZE (inch)	L (mm)	H (mm)
15	G1/2"	46	68

Description	Air Vent Valve
Model No.	1035
Material	Brass H57-3
Working Medium	Water
Working Temperature	5°C ≤ t ≤ 80°C
Normal Pressure	≤ 16bar
Connection Thread	ISO 228