

# Spinal Traumatic System

Operation manual

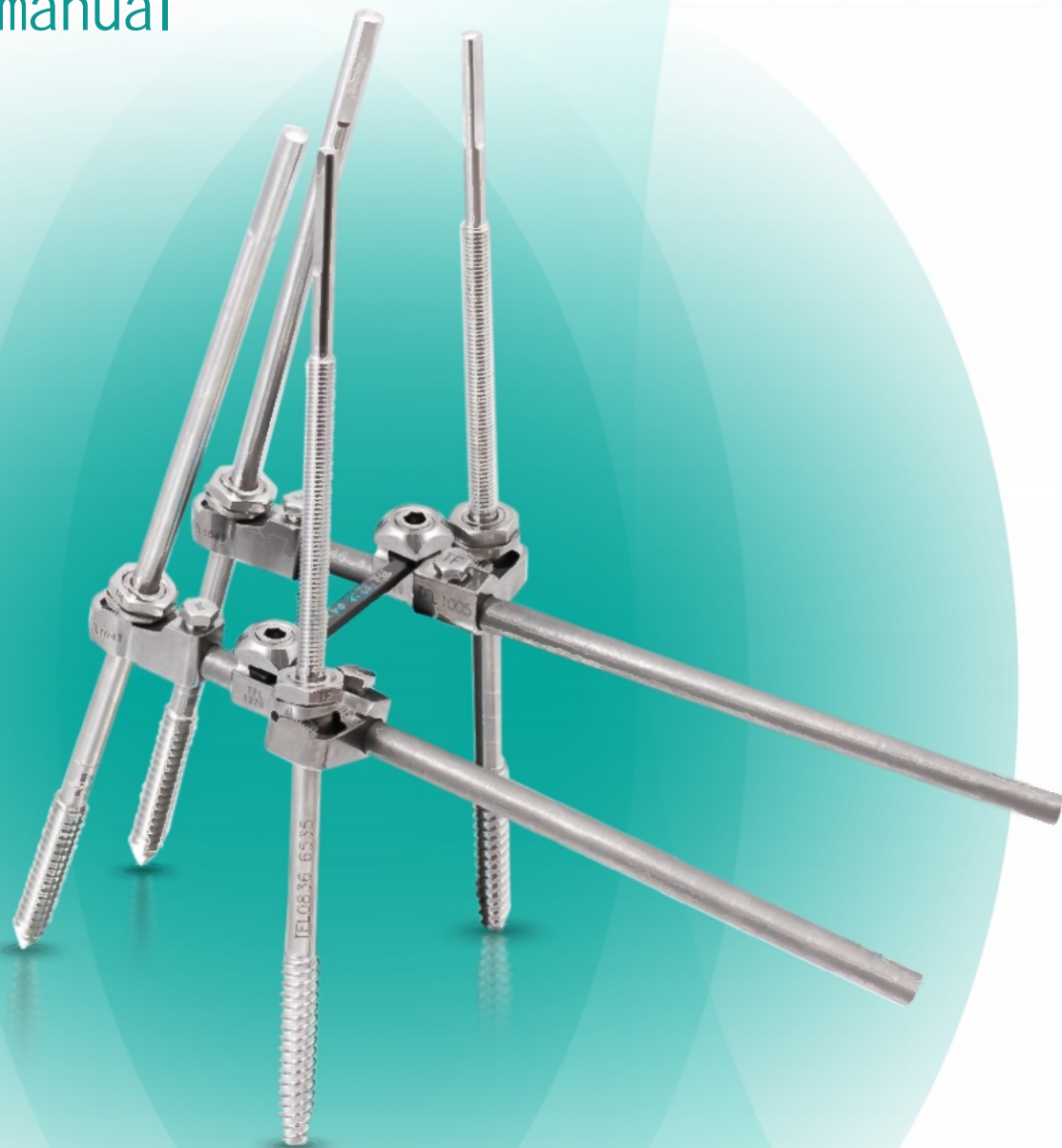

## Why choose Fule?

### Our Advantage

The company is a national high-tech enterprise integrating research and development, production and sales of medical devices, with full intelligent processing equipment production line.

Academician and expert studio was established to help Fule improve its R&D capabilities and further deepen production-study-research cooperation; Approved postdoctoral research station.

With complete hardware facilities, excellent research and development team, and close cooperation with clinical experts, we have obtained more than 100 domestic and foreign patents.

Based on the agent cooperation pattern, to establish a nationwide sales and service network, product supply nearly thousand 3 armour hospital in our country, are exported to more than 20 overseas countries.

# Content

Product advantage.....	01
Instructions for use.....	03
Surgical procedure.....	04
Product information.....	14
Instrument information.....	15



Beijing Fule Science&Technology Development Co.,Ltd

Post Code:101204

Sale hot line:010-60999861/2 Fax:010-60999863/8741

Tel:010-60999866/32/75/17 E-mail:YXSC@fulekejicom

Add:No.50, Mafan g West Industry Zone,Pnggu District,Beijing

## Product Advantage

- After the long tail is sheared, the residual incisure is low, and the stimulation of the surrounding soft tissues is small.
- Double-thread design, fast nail insertion, shorten the operation time.
- Long tail lift thread design, lift of vertebral body slippage effect is remarkable.
- It has a good stretching effect on the treatment of vertebral compression fractures.



Sleeve Chuck



Sleeve Chuck (End Part)



SCHANZ Pedicle Screw I



SCHANZ Pedicle Screw ( Double thread pedicle screw )

## Instructions for use

- **【indication】**  
Lumbar spondylolisthesis
- **【Contraindication】**  
No contraindications

## Surgical procedure

### 【Step1】 Prepare approach and nailing path

- Posterior midline incision, subperiosteal dissection joints between lamina and articular process.
- Using the conventional thoracolumbar pedicle approach, the entry point is prepared with an open drill, the hole is deepened to 3cm with a reentrant vertebra, a Kirschner wire is inserted into the screw hole, and the direction of the pedicle hole is examined by fluoroscopy (Fig. 1a).
- After fluoroscopy shows that the screw hole is in correct position, the hole is further enlarged with the retractor, tapped with a tap if necessary, and then a probe should be used to confirm that the walls of the screw path are bone tissue and that the pedicle wall is not penetrated (Fig.1b).

The following pictures are not from the art designers in the industry, only to illustrate the use of the product process and the matters needing attention, not as anatomical reference

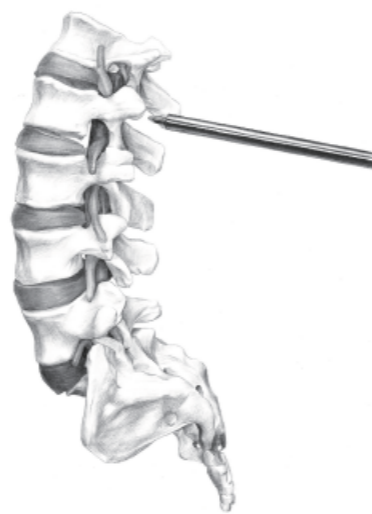

Fig. 1a



Fig.1b

## Surgical procedure

### 【Step 2】 Screw in the pedicle screws

- Use a triangular socket wrench to implant the SCHANZ Pedicle Screw I into the nail path to a depth of 2/3 of the vertebral body (Fig.2a).
- After placement of the four SCHANZ Pedicle Screws I, fluoroscopy is performed to ensure that the anterior cortical bone of the vertebral body has not been penetrated (Fig. 2b).

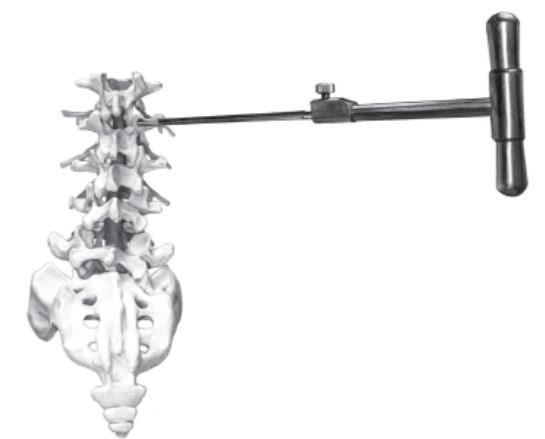

Fig.2a



Fig. 2b

## Surgical procedure

### 【Step 3】 Implant sleeve chuck and rods

- Assemble every two sleeve chucks with one rod. Be careful not to pretighten the sleeve chucks at this time, and keep the range of motion between the sleeve chuck and the rod to facilitate the next installation. (Fig.3a).



Fig.3a

- The assembled sleeve chuck and rod were inserted along the long caudal end of the SCHANZ Pedicle Screw I, noting that the direction of the rod should be close to the spinous process. (Fig.3b).

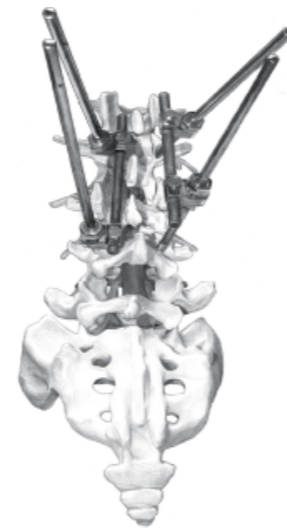

Fig.3b

## Surgical procedure

### 【Step 4】 Reduction of A1 and A2 type fractures

- First, two 11mm socket wrenches are inserted into the SCHANZ Pedicle Screw I at the tail end and tilted towards the tip to create lordosis in the spine, and then the 11mm nut of the sleeve chuck is locked. The same operation is done on the SCHANZ Pedicle Screw I at the head end, and the normal sagittal plane of the vertebral body can be reconstructed in these two steps. (Fig. 4a).

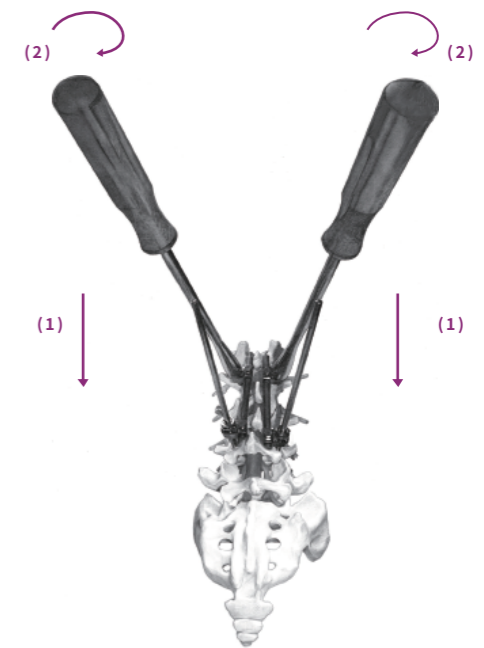

Fig. 4a

- First plate drive socket wrench to open the leading edge.
- the socket wrench clockwise to lock sleeve chucks.

- After anterior distraction is completed, a parallel distraction operation is performed in conjunction with the turn pliers to restore vertebral height and reduce pressure on the disc (Fig. 4b).

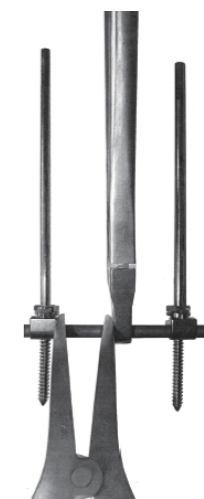

Fig.4b

## Surgical procedure

### 【Step5】 Reduction of the A3 fracture

- In this type of fracture, compression of the posterior arm of the vertebral body should be avoided because there is a theoretical situation in which the fracture fragment of the posterior arm of the vertebral body enters the spinal canal.
- On the two SCHANZ Pedicle Screws I on one side, first fix the two turn pliers at a distance of 5mm from the sleeve chuck (Fig.5a), or lock the 6mm nut directly (Fig.5b), and then set the two 11mm socket wrenches for unilateral distraction operation. After the distraction is in place, lock the 11mm nut.

Do the same on the other side.

If you need to recover the height of the vertebrae by spreading them parallel, see above.

- a, loose 6mm nut
- b, locked 6mm nut

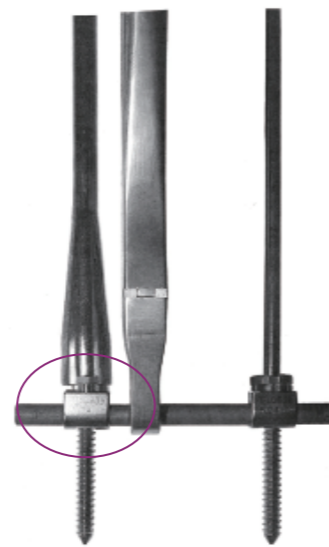

Fig.5a

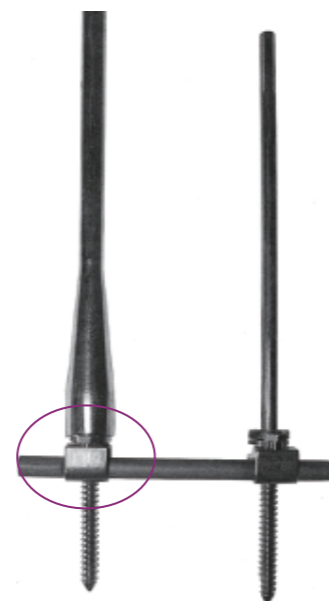

Fig.5b

## Surgical procedure

### 【Step 6】 Reduction of type B and type C fractures

- Type B fracture is the rear of the structure of the fractures or tension fracture, the effect of the implant inside to pure tension band, in according to the method of the reset, the need for open but with slight pressure.

The internal fixation of type C fractures is a neutralizing device, and the reduction technique is as described previously. In order to combat rotational and shear forces, it is necessary to install transverse connectors.

## Surgical procedure

### 【Step 7】 Final locking

- The 6mm nut was locked completely to secure the entire internal fixation structure while maintaining parallel distraction.

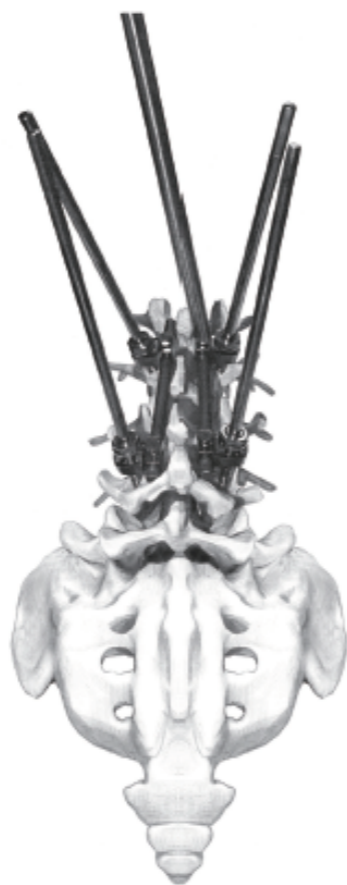

Fig.7a

## Surgical procedure

### 【Step 8】 Cut the long arm

- The long arm of the SCHANZ Pedicle Screw I is cut off using a system-specific turn pliers.



Fig.8c

## Surgical procedure-annotation

### 【Step 1】 SCHANZ pedicle screw for treatment of spondylolisthesis

#### 1、Preparation of the dowel

#### 2、Insertion of nails

-Two SCHANZ Pedicle Screws are inserted into the slippage vertebra, and two additional SCHANZ Pedicle Screws or two common fixation screws are inserted into the vertebra below them as fulcrums for lifting.

#### 3、Screw in the lifting sleeve

-Screw the pull sleeve into the long tail of the pedicle screw until the top reaches the sleeve chuck (Fig. 1a).

- (1) Screw the lifting sleeve into the long tail of SCHANZ pedicle screw.
- (2) Pull the sleeve and screw in

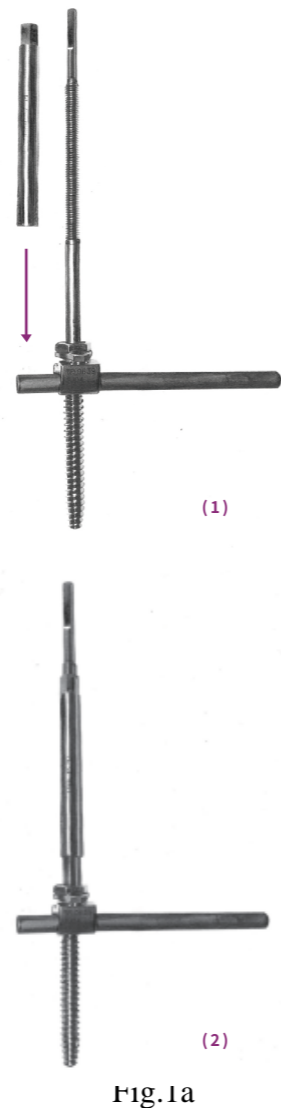

Fig.1a

## Surgical procedure-annotation

### 【Step 2】 SCHANZ pedicle screw for treatment of spondylolisthesis

#### 4、Pulling

- The lifting nut is placed in the hexagonal mouth of the lifting sleeve, and then the nut is turned clockwise to realize the upward movement of the SCHANZ pedicle screw with respect to the sleeve chuck and rod, and at the same time, the sliding vertebral body is driven upward to realize the lifting (Fig. 2a).

- (1) Turn the lifting nut clockwise.
- (2) The sleeve chuck and rod are pressed downward.
- (3) SCHANZ pedicle screw drive slippage vertebral body lift up.

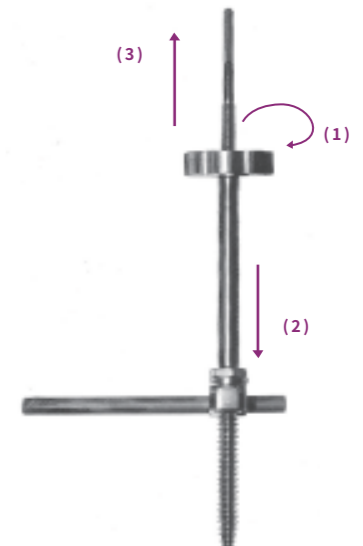

Fig. 2a

#### 5、Locking

-When the lifting is complete, remove the lifting nut, tighten the 1mm nut with a socket wrench, and remove the lifting sleeve (Fig. 2b).

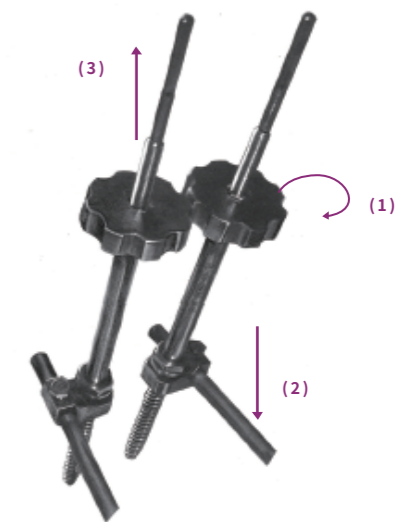

Fig.2b

## Product information

### ● 【SCHANZ Pedicle Screw I】

		Screw length (mm)				
		30	35	40	45	50
Screw diameter (mm)	5.0	*	*			
	5.5		*	*	*	
	6.0		*	*	*	*
	6.5		*	*	*	*



### ● 【SCHANZ Pedicle Screw】

		Screw length (mm)				
		30	35	40	45	50
Screw diameter (mm)	5.0	*	*			
	5.5		*	*	*	
	6.0			*	*	*
	6.5			*	*	*



### ● 【Sleeve Chuck】

Product Code	Remark
040301000	Hexagonal SW6.0



### ● 【Sleeve Chuck ( End Part )】

Product Code	Remark
040801000	Hexagonal SW6.0



## Instrument information



● 106-010  
Wrench (socket triangle)



● 121-030/031/032  
Temper (φ5/φ5.5/φ6)



● 121-040  
Wrench (socket) S=6



● 121-050  
Wrench (socket) S=11



● 106-061  
Screw remove pliers



● 106-050  
Wrench (adjust rod)

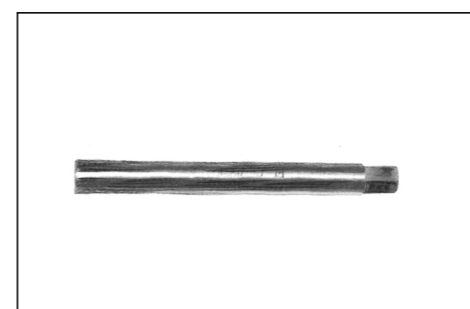

● 106-051  
Wrench (adjusting sleeve)

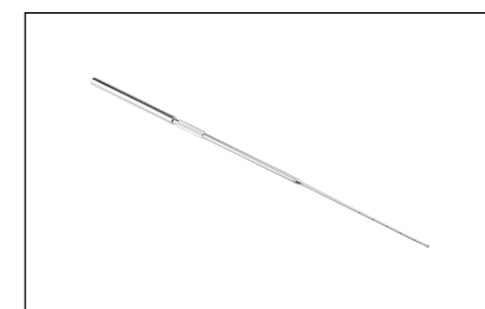

● 101-022  
Probe (adjusting sleeve)

## Instrument information



● 101-501  
Screwdriver (hex) S=3.5



● 113-220  
Holding hook forceps



● 113-210  
Holding forceps

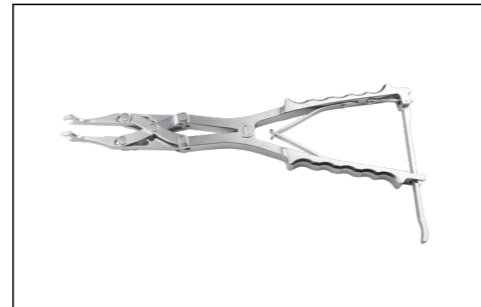

● 113-230  
Distractor

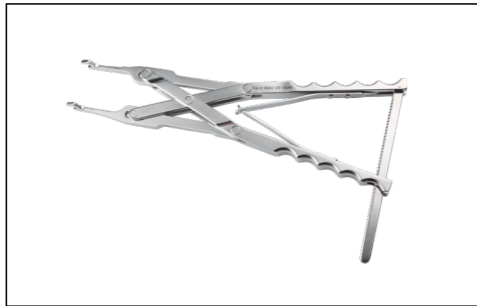

● 113-240  
Compression forceps



● 101-104  
Bending Forceps



● 101-123  
Rod Rotation Clamp

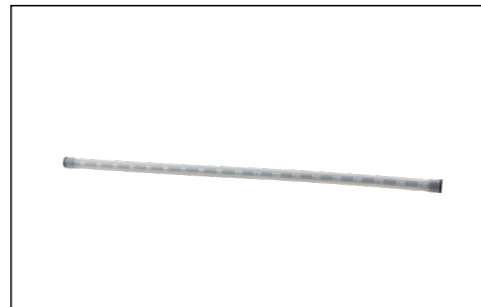

● 101-130/131  
Template

## Instrument information



● 113-160  
Bone positioning Pin(box)

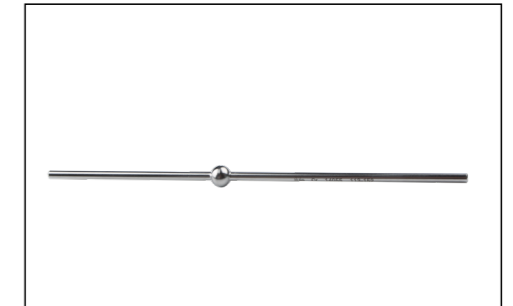

● 113-152  
Bone positioning Pin(ball head)

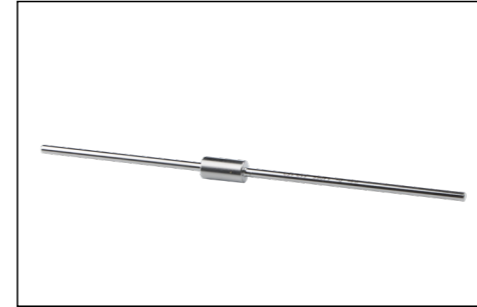

● 113-153  
Bone positioning Pin(stigma)



● 101-208  
Open Drill



● 111-052  
Expanding Awl



● 104-081  
Rod Cutter

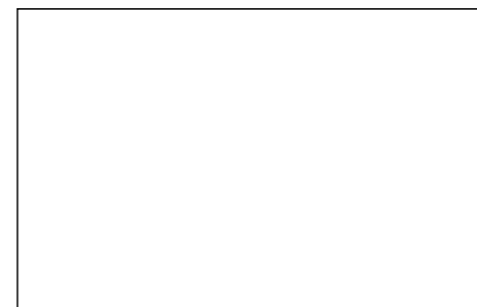

● 121-010/011  
Bone grafting instrument (funnel)φ6/φ8



● 121-020/021  
Bone grafting instrument (ramming rod) φ5/φ7

## Instrument information

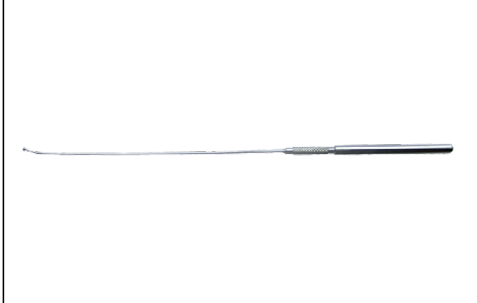

● 101-023  
Bone probe (bend)

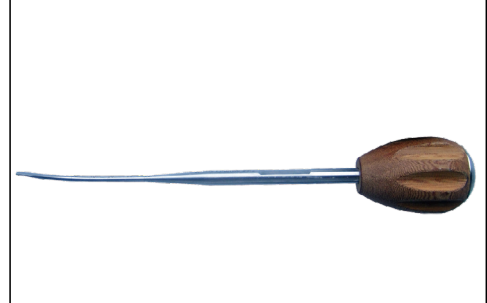

● 101-209  
Reamers (bend)

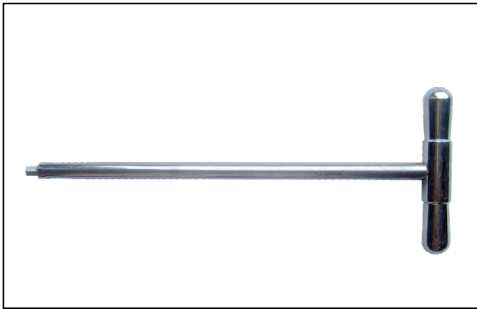

● 101-260  
Screwdriver (hexagon T type) S=4