

ZMJ100PR Density Monitor



ZMJ100PR Density Monitor

Description

ZMJ100PR Density Monitor is used to monitor the density of SF₆ gas in the sealed gas tanks, which can locally display the gas density on-site, and send alarm signals when the density reaches the set values. Furthermore, it can transmit the real-time SF₆ gas density data remotely, to achieve online remote monitoring function. Ideally suited for the high voltage systems. It can be used in the new substation building and the renovation and upgrading of existing substation.

Application

- SF₆ Gas Insulated Switchgear (GIS)
- SF₆ Insulated Circuit Breaker
- SF₆ Insulated Pole-Mounted Switch
- SF₆ Insulated Transformer
- SF₆ Insulation Current Transformers or Voltage Transformers
- SF₆ Insulated Bus System

Options

- Withstand voltage: 2.5kV, 50/60 Hz 1min
- Oil filled or not
- Can detect SF₆, Air, N₂, SF₆+N₂ and other gases
- Communication: 4-20mA(Two wire)
- Wider temperature range: optional -40°C ~ +60°C or -60°C ~ +60°C
- Optional measurement accuracy: ±1.6%FS (+20±1°C) , ±2.4%FS (-20°C~ +60°C) (gas phase)

Features

- With temperature compensation, ensuring higher measuring accuracy.
- Mechatronics design, has precision mechanical structure, and has real-time remote transmission function of electronic signals and on-site display and control. RS485 bus interface, easy to do the system expansion, and to achieve telemetry, remote control functions. Strong EMC capability. Suited for different indoor and outdoor installation requirements.
- AISI 304 hermetically sealed stainless steel case.
- The connecting parts are made of AISI 316 stainless steel.
- The field display value and output signal are not affected by the external environment such as altitude. Up to sets of contacts, can achieve a variety of double options such as alarm and double lock for safer and more reliable monitoring.

Technical parameters	
Case diameter	100mm
Scale range	-0.1 ~ 0.9MPa(customizable)
Accuracy	±1.0%FS (+20±1°C) , ±1.8%FS (-20°C~ +60°C) (gas)
Degree of protection	IP65
Ambient condition	-20°C ~ +60°C relative humidity ≤ 95%
Leakage rate	≤ 1×10 ⁻⁹ Pa·m ³ /s (Helium leakage inspection)
Process connection	M20 x 1.5 (customizable)
Installation method	Radial or axial
Electrical connection	Pluggable connector, wire diameter 1~ 2.5 mm ² (1.5mm ² recommended)
Insulation property	Insulation resistance: >100MΩ (DC500V) Power frequency with stand voltage: 2kV, 50/60Hz, 1min
Contact type	Magnetic snap-action switch (80% Ag, 20% Ni, 10μm gold plated)
Impact rating	50g(Oil-filled), 30 g(Non-oil-filled)
Contact electrical parameters	30W/ 50VA, 1A. max. 220VDC/ 380V 50/ 60Hz max.
Watch glass	Laminated safety glass
Weight	≈ 1.2kg
Pressure element	Bourdon tube

Dimensions

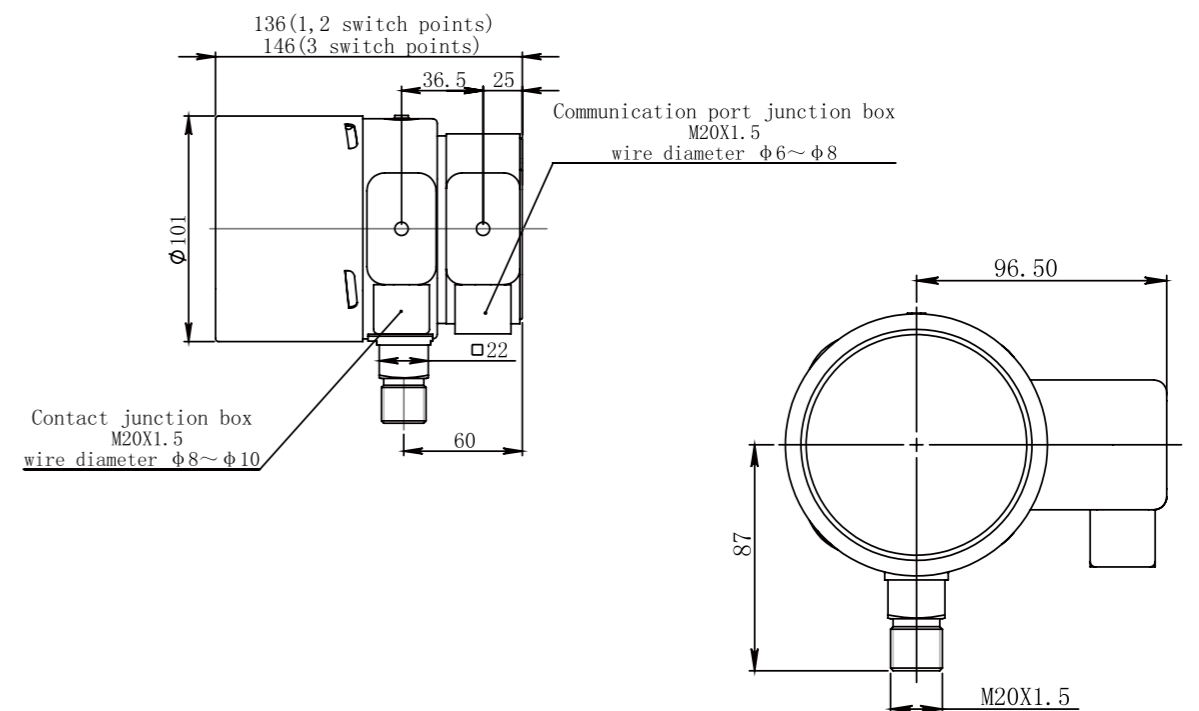

Technical Parameters for Remote Module

Operating voltage	10~30VDC	EMC tests	IEC61000-4-2: Level 4
Power consumption	<0.5W		IEC61000-4-3: Level 3
Communication mode	RS485		IEC61000-4-4: Level 4
Communication protocol	Modbus RTU		IEC61000-4-5: Level 3
Baud rate	9600bps		IEC61000-4-6: Level 3
			IEC61000-4-8: Level 5