

Contents

1. Introduction.....	1
2. Curriculum.....	4
3. Activities.....	10
3.1 Movable long nose.....	10
3.2 Wipers.....	18
3.3 Drilling machine.....	26
3.4 Night expert.....	34
3.5 Gate.....	42
3.6 Elevator.....	50
3.7 Juicer.....	58
3.8 Sluice.....	66
3.9 Beneficial Insects and Pests.....	74
3.10 Dutch windmill.....	82
3.11 Longevity Star.....	90
3.12 Rotating Flying Chair.....	98

Introduction

Nashenbot is a cutting-edge company dedicated to the research and development of educational robots powered by artificial intelligence. We are delighted to offer programming kits to teachers, allowing young students in lower grades to progressively grasp programming concepts through our comprehensive curriculum.

Who is it for?

This material is tailored for teachers of kindergarten senior classes and primary school lower grades. It enables students to enjoy the excitement and acquire knowledge of AI programming without requiring access to a computer or tablet.

What is it for?

Programming education integrates physical hardware and software programming, where students learn to sequence actions for robots to accomplish specific tasks by engaging in design, construction, assembly, and programming. This educational approach fosters scientific enlightenment by sparking children's interest in learning, observation, thinking, exploration, hands-on practice, and collaboration. It is an educational methodology aimed at nurturing children's comprehensive abilities while blending education with entertainment.

What is it?

The programming kit boasts a specialized storage box housing the controller, a closed-loop motor, a red light, an infrared obstacle avoidance sensor, and several other electronic parts. These components empower students to program and manage the robot they construct. Furthermore, the kit incorporates a user manual detailing the basic functionalities and a comprehensive part list, ensuring enhanced usability of the product.



How to use?

Building instructions

The 12 building instructions offer detailed, step-by-step guidance on constructing each model, facilitating the process for students. However, transitioning from 2D instructions to building a 3D model can be challenging, and some students may require assistance and encouragement from their teachers. Therefore, we advise students to follow the instructions on the card precisely to ensure the model functions correctly during activities. These building instructions not only aid in construction but also contribute to expanding and deepening technical knowledge.

Teacher's Guide

In the Teacher's Guide, you will discover 12 engaging activities that incorporate stories, inquiries, and additional ideas for exploration, complete with all necessary classroom materials prepared for teachers. Each activity is tightly aligned with the overarching goals of the science, design, and technology curriculum. Prior to each activity, we outline the relevant knowledge points, the objectives for fostering student abilities, and the required material preparations. The shared outcomes of all activities are summarized in the "Curriculum Focus" section. Furthermore, we detail the specific key vocabulary and additional materials needed for each individual activity.

Connect

Introduce Jack and Lilia through a short story to engage students in identifying a problem and researching how to devise an effective solution. Teachers can read this story aloud to the students or retell it in their own words, encouraging students to empathize with Jack and Lilia and identify the problem they face. Based on their personal experiences and the scenes depicted in any animations provided, teachers can create relevant scenarios for students to immerse themselves in.

Construction

Students utilize the provided building instructions to construct the model, with the model's structure serving as a tangible representation of the key learning points and related concepts. Throughout this learning session, detailed steps for model building are outlined to guarantee that students can successfully assemble the model, enhancing their understanding and retention of the material.



Problem Solving Activities

Each of the four problem-solving activities is introduced through an engaging, illustrated short story that presents a problem to be solved. The design brief accompanying each activity outlines the criteria students must adhere to while building their model to find a solution. The "Fair Testing and Fun" questions and sample answers ensure that the models remain focused on meeting the design brief criteria and support the testing situation effectively.

The provided sample model solution serves as a helpful guide for teachers to offer insights and guidance to students. However, it's important to note that this is not the only solution to the problem. Teachers should always inspire students to build upon the given problem and discover their own unique solutions.

If feasible, teachers can capture photos of students and their model solutions, and ask them to explain their thought process and solution approach. These photos can serve as a source of inspiration for future students, fostering a collaborative and innovative learning environment.

How much time do teachers need?

Each activity is designed to be completed within a single class period, although two class periods provide an optimal environment for a more thorough exploration of the learning focus and allow students to unleash their creativity fully. When dealing with open-ended problem-solving activities, students may require additional time to construct and articulate their models effectively. This additional time is crucial for fostering deep learning, encouraging innovation, and refining their problem-solving skills. By allocating sufficient time, teachers can ensure that students have the opportunity to engage fully with the material and produce high-quality work.



What are the curriculum highlights?

Students acquire a diverse array of skills, knowledge, and comprehension through active construction, exploration, investigation, inquiry, and interaction. For a comprehensive understanding, please refer to the curriculum provided on the following page. Below is a brief summary:

Science

Students engage in studying how energy, force, speed, and friction interact, read and interpret scales, conduct fair experiments, make predictions and measurements, gather data, and articulate their findings.

Design and Technology

Explore the functionality of gears, wheels, axles, levers, and pulleys; tailor solutions to meet specific needs and choose suitable materials; design, construct, and assess prototypes; create three-dimensional models based on two-dimensional instructions; collaborate in teams; and provide evaluations.

Math

Take both non-standard and standard measurements of distance, time, weight (mass), and interpret scales. Engage in counting, calculation, shaping objects, and solving problems.

Micro Brain programming

Micro-brain programming offers a straightforward, user-friendly, and efficient approach to coding. Its modular structure and visual programming interface facilitate ease of use, making it an ideal option for beginners and non-technical individuals.

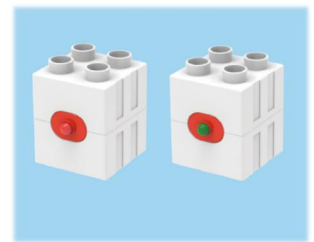

What are the curriculum highlights?

	Main science courses	Main Design and Technology courses	Programming
	Scientific exploration entails studying how variables influence the properties of simple machines, predicting and estimating their characteristics, conducting meticulous observations, and accurately describing and presenting the findings.	Develop expertise and understanding by working with a variety of mechanical and structural components. Evaluate products against technical standards and improve design capabilities.	By arranging and combining different program blocks to achieve different effects, we can cultivate logical thinking ability. Deal with problems in a structured and analytical way and seek solutions through systematic reasoning.
1. Movable long nose	<ul style="list-style-type: none"> ● Research perspective ● Interlocking structure 	<ul style="list-style-type: none"> ● Material properties ● Design 	<ul style="list-style-type: none"> ● Real-time control ● Motor direction
2. Wipers	<ul style="list-style-type: none"> ● Turbine structure ● Graphics 	<ul style="list-style-type: none"> ● Mechanism: turbine 	<ul style="list-style-type: none"> ● Obstacle avoidance module ● Motor direction
3. Drilling machine	<ul style="list-style-type: none"> ● Gear transmission ● Luminous flux 	<ul style="list-style-type: none"> ● Design mechanical toys ● Structure and stability 	<ul style="list-style-type: none"> ● Real-time control ● Speed module
4. Night expert	<ul style="list-style-type: none"> ● Rotation around an axis ● Circular motion 	<ul style="list-style-type: none"> ● Rotation around an axis ● Design mechanical toys 	<ul style="list-style-type: none"> ● Speed module ● Loop module
5. Gate	<ul style="list-style-type: none"> ● Crank structure 	<ul style="list-style-type: none"> ● Mechanism: crank structure 	<ul style="list-style-type: none"> ● Motor direction / Obstacle avoidance module
6. Elevator	<ul style="list-style-type: none"> ● Crank connecting rod 	<ul style="list-style-type: none"> ● Mechanism: crank connecting rod 	<ul style="list-style-type: none"> ● Motor direction ● Motor speed
7. Juicer	<ul style="list-style-type: none"> ● Read scale to measure water level ● Application of pulley 	<ul style="list-style-type: none"> ● Mechanism: pulley 	<ul style="list-style-type: none"> ● Stop module ● Obstacle avoidance module
8. Sluice	<ul style="list-style-type: none"> ● Gear reduction ● Study of connecting rod 	<ul style="list-style-type: none"> ● Mechanism: connecting rod 	<ul style="list-style-type: none"> ● Loop module ● Speed module
9. Beneficial Insects and Pests	<ul style="list-style-type: none"> ● Reciprocating motion ● Circular motion 	<ul style="list-style-type: none"> ● Mechanism: crank connecting rod 	<ul style="list-style-type: none"> ● Obstacle avoidance module ● Motion module
10. Dutch windmill	<ul style="list-style-type: none"> ● Wind generation ● Two-point fixation 	<ul style="list-style-type: none"> ● Gear drive 	<ul style="list-style-type: none"> ● Lighting module ● Real-time control
11. Longevity Star	<ul style="list-style-type: none"> ● Follow-up programming ● Gear rotation 	<ul style="list-style-type: none"> ● Mechanism: crank connecting rod 	<ul style="list-style-type: none"> ● Real-time control ● Obstacle avoidance module
12. Rotating Flying Chair	<ul style="list-style-type: none"> ● Centrifugal force ● Motion trajectory 	<ul style="list-style-type: none"> ● Mechanism: central axis drive 	<ul style="list-style-type: none"> ● Lighting module ● Obstacle avoidance module

Curriculum

Early Science and Technology Learning Forms

	Elephant	Owl	washing Machine	Gate	Wipers	Sluice	Rotating flying chair	Sea Turtles	Dutch Windmill	Juicer	Elevator	Caterpillar
Science												
Scientific Exploration												
Conduct simple research												
Collect information using simple equipment and tools												
Communicate about research and explanations												
Fair Testing												
Material properties												
Describing location and direction												
Describe the activity												
Gear acceleration and deceleration												
Observe												
Reasoning												
Sharing research findings												
Teamwork												
Technology												
Conduct design conception and put ideas into practice												
Problem solving through Design												
Build and test												
Improve												
Explore how it works												
Structure												
Use tools with purpose												
Express your ideas to others												
Project												
Identify the need or problem												
Testing and Evaluation												
Redesign												
Meeting design constraints												
Math												
Integer relations												
Using standard and non-standard units												
Add and subtract integers												
Estimate												

1. Movable long nose

We can learn about the living habits and morphological characteristics of elephants through courses; In terms of programming, we mainly learn about the main controller, motor, direction, etc., and learn how to operate the main controller to control the up and down swing of the nose.



2. Wipers

We can learn the role of windshield wipers through the course and explore the instability of quadrilaterals.; In terms of programming, we can use the direction and speed modules to control the wiper to work better.



3. Drilling machine

Through this course, we can learn about the structure and function of the drilling machine, complete the vertical meshing of two gears using the crown gear the large gear, and get familiar with the obstacle avoidance sensor in the programming section, enabling the drilling machine to start working upon contact with the target



4. Night expert

Through the course, we can learn about the living habits and morphological characteristics of owls and understand the characteristics of multi-gear structures. In terms of programming, we can control the motor to make the owl's eyes move, and we can also try the sound module to make different sounds.



5. Gate

Through this course, we can learn about the functions and types of barriers, explore the characteristics of quadrilaterals, and know the instability of quadrilaterals. ; In terms of programming, we mainly understand clockwise and counterclockwise rotation to control the rise and fall of the gate.



6. Elevator

Through the course, we can learn the composition and structure of elevators and understand how to deal with unexpected situations in elevators; In terms of programming, we control the up and down movement of the elevator by direction, and use the controller to make the elevator run automatically.



7. Juicer

We can learn the structure and function of the juicer through the course, and understand the crown gear and large gear;In terms of programming, we use the speed module to control the speed of the juicer, and the light module can be used to display the status of the juicer.



8. Sluice

We can learn how to prevent floods and understand the hazards of floods through courses, and understand the role of sluice gates.; In terms of programming, we learned about obstacle avoidance sensors, which are used to judge the rise and fall of water levels to decide whether to close or open the sluice gate.



9. Beneficial Insects and Pests

Through the course, we can learn the transformation process of the caterpillar, understand the application of the rack, and convert the circular motion of the gear into the linear motion of the gear; In terms of programming, the speed of the caterpillar is controlled through real-time manipulation.



10. Dutch windmill

Through the course, we can learn the structure and components of the Dutch windmill, build the fan blade part using the two-point fixed principle, and learn about gear transmission and belt transmission. In the programming part, we learned the loop module and used it to make the windmill work continuously.



11. Longevity Star

We can learn about the living habits and mental characteristics of turtles through the course, and understand the crank structure ; In terms of programming, you can try real-time control, controlling the speed of the turtle, and using obstacle avoidance sensors to detect whether there are any obstacles ahead.



12. Rotating Flying chair

We can learn the running track and the principle of rotating the flying chair through the course. In terms of programming, you can use the direction and speed modules to control the operation of the rotating flying chair, and the use of colored lights can make the rotating flying chair more beautiful.



1. Movable long nose

Science

- Ascending and descending
- Center of gravity
- Contact area
- Rotation

Design and technology

- Parts inspection
- Assemble the model
- Test

Vocabulary

- Nose
- Angle
- Drop
- Length

Programming

- Main controller
- Real-time control
- Direction module

Connect

During a school trip to the zoo, Jack and Lilia saw a fascinating scene: a group of elephants playing in the water, spraying each other with water using their extremely flexible trunks. Inspired by the elephants' trunks, Lilia and Jack decided to make their own elephant model.

Back home, they began to experiment with various trunk designs, both long and short, aiming to achieve the most realistic and effective effect.

Lilia successfully made her elephant model, but despite Jack's best efforts, he had a hard time getting the elephant's trunk to move. Can you help Jack and Lilia make an elephant with a dynamic trunk? Let's embark on this creative journey together.



Build

Follow the step-by-step building instructions to build the elephant:

- Ensure consistent angles: Keep the angle of the trunk equal to the ground to maintain balance.
- Thick legs: The elephant's legs should be designed to be relatively thick to increase the contact area with the ground and achieve stability of the model.
- Adjust the height of the legs: If the model seems to lean to one side after construction, it means that the model is built too high, causing its center of gravity to rise. To solve this problem, try reducing the length of the legs, which will lower the center of gravity of the model so that the model can stand more stably on the ground.



WARNING!

Motors can pose risks, so it is important to ensure that children are careful when programming with motors.

Movable long nose

We adjusted the initial state of the elephant's trunk so that it was in different positions. Next, we programmed the elephant to lift and lower its trunk and record the time it took to do so.

First, predict how long it would take the model to lift and lower its trunk and record your predictions using the worksheet provided.







Then, test how long it would take the elephant's trunk to lift and lower and record your observations using the worksheet.

The model was able to lift and lower its trunk by programming the motor to rotate forward or backward.

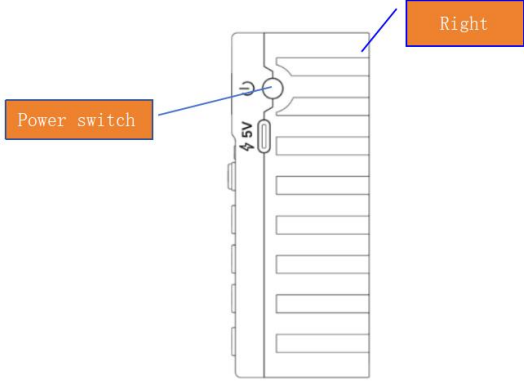
To ensure a fair test, think about the following questions:

- What did you predict would happen and why?
- Describe what actually happened.
- How would you ensure a fair test? Consider whether the difference in the trunk state was visually obvious, whether the initial angle between the elephant's trunk and the ground was consistent, and whether the motor speed and timing were set the same when programming the code.
- Explain how the model works.
- What do you think are the most important factors in making a good elephant model? Trunk length, initial angle, movement performance, etc.

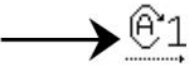
Programming

<p>Understanding the controller</p>	 <p>The power switch is on the right side of the controller. Press and hold it once to turn on the controller, and press and hold it again to turn off the controller.</p>
<p>Support three modes</p>	 <p>Real-time control Programming mode Bluetooth model</p>
<p>Motor and electronics interface</p>	 <p>Connection notes: When programming, the selected buttons should correspond one to one with the port connections.</p>
<p>Mode selection</p>	 <p>In real-time mode, we only need to connect the controller to the motor and press the corresponding button to control the model to respond.</p>
<p>Program Example</p>	<p>1.  X1 →  2.  X1 → </p>

Expand

Can you imagine making a new type of trunk for your elephant? Use your creativity to design your own trunk! Try different trunk shapes and decorate them on your elephant model. Think about which shape would be the most beautiful. Draw the shape of the trunk you think would be the most beautiful on the worksheet.

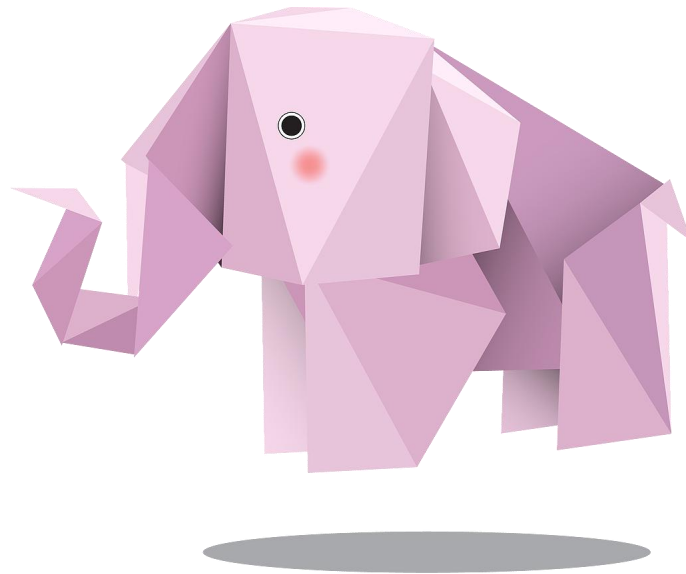

Expand

Can you design a novel nose?

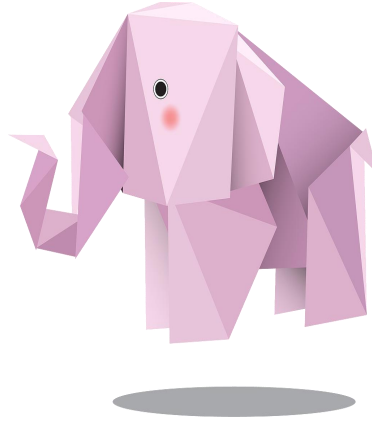

Design different trunk shapes for your elephant and trace them below!

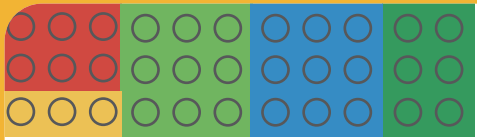

Movable long nose - Elephant

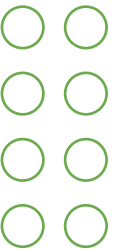
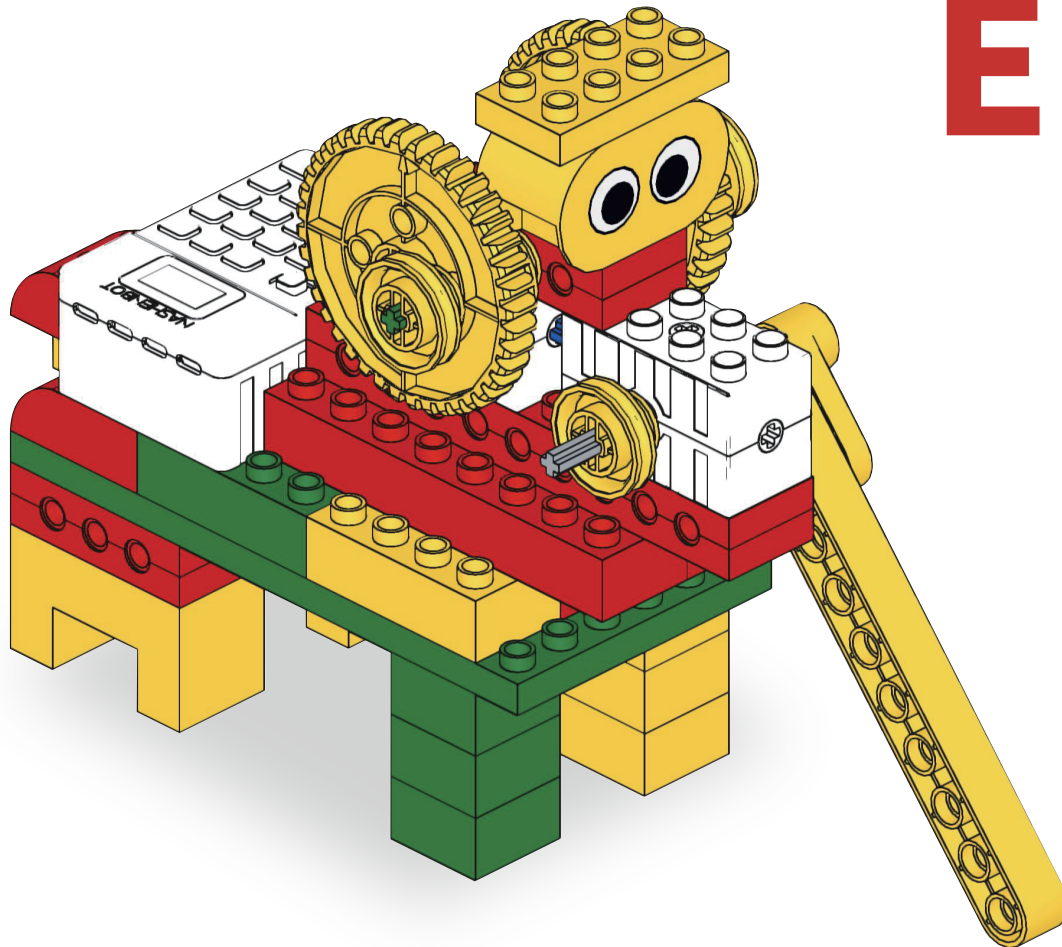

Building Manual

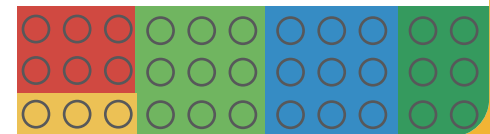

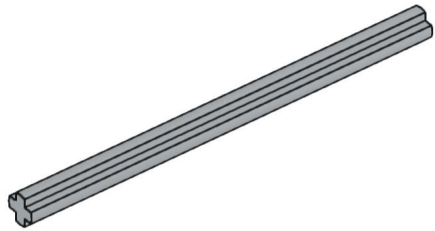

1x

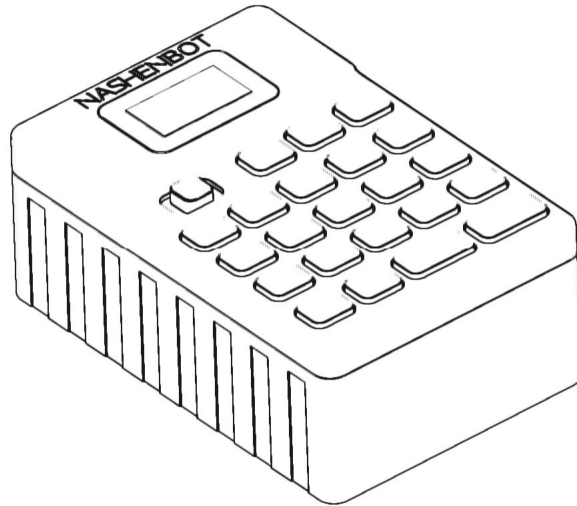

1x

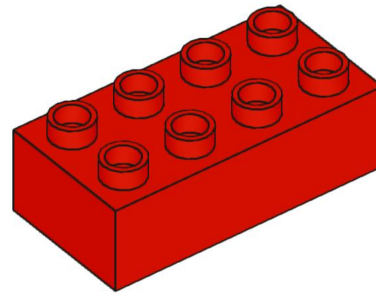

1x

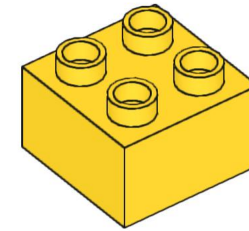

3x

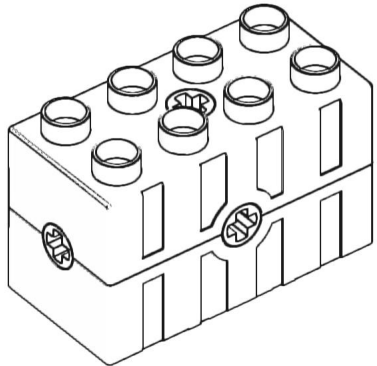

1x

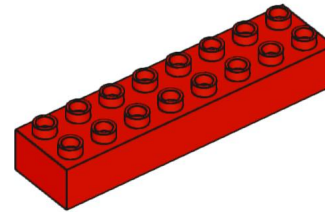

2x



1x

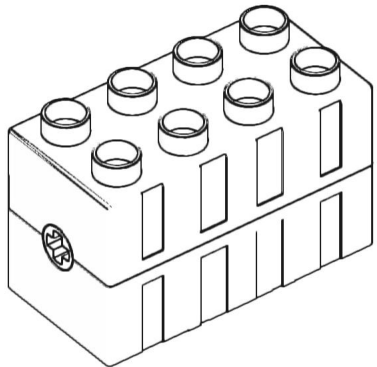

1x

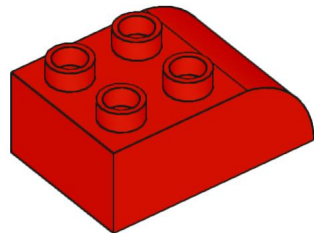

3x

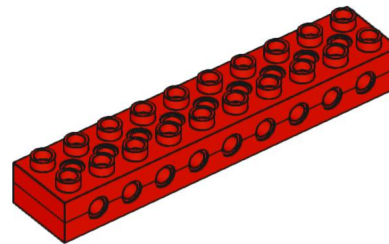

1x

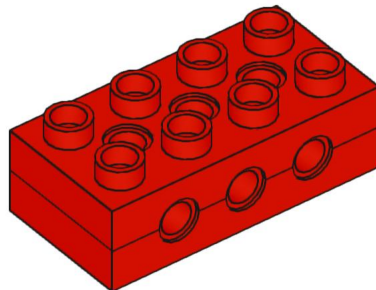

3x

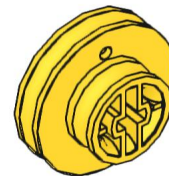

5x

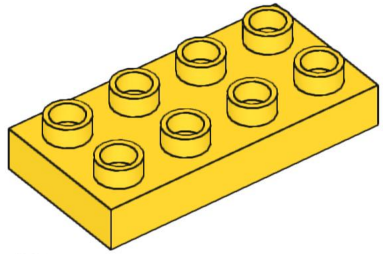

2x

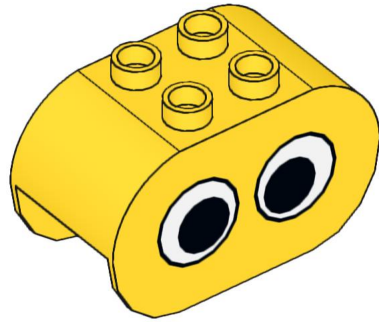

1x

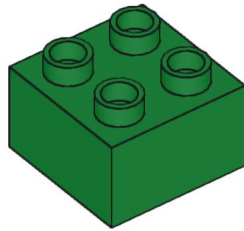

3x

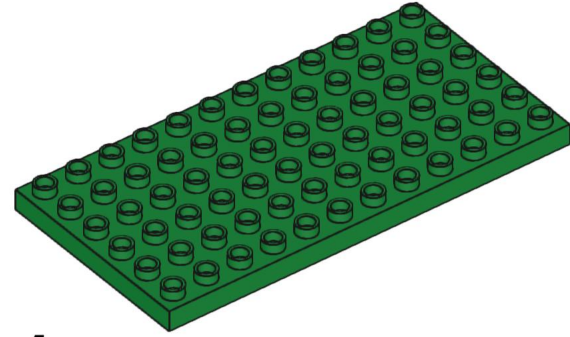

1x

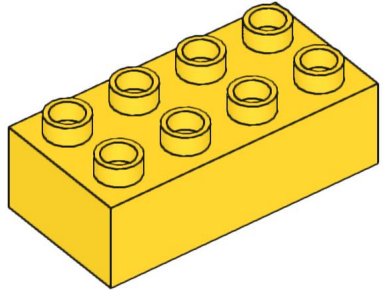

2x

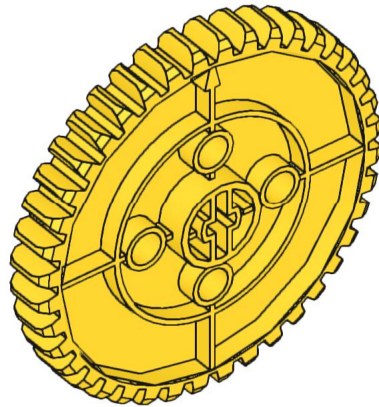

2x

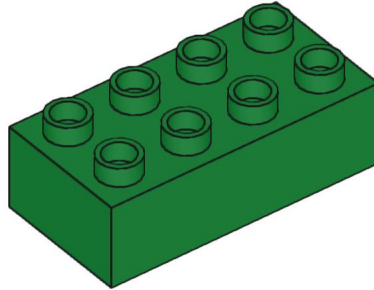

3x



1x

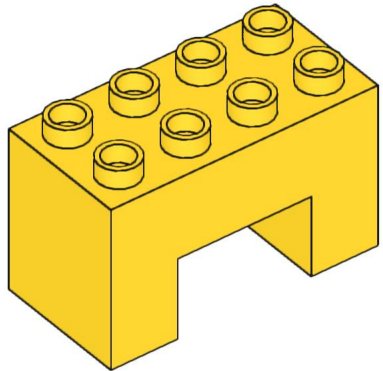

2x

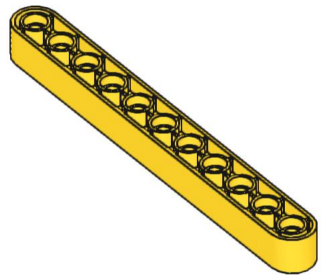

1x



1x

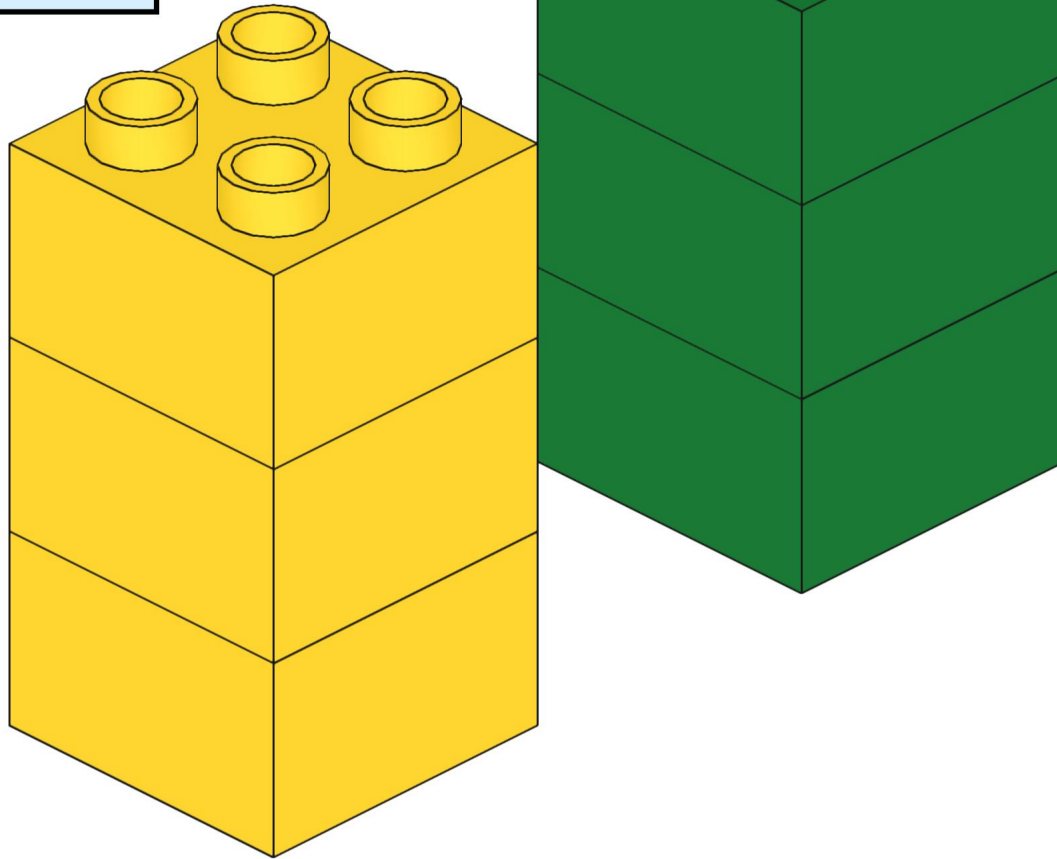
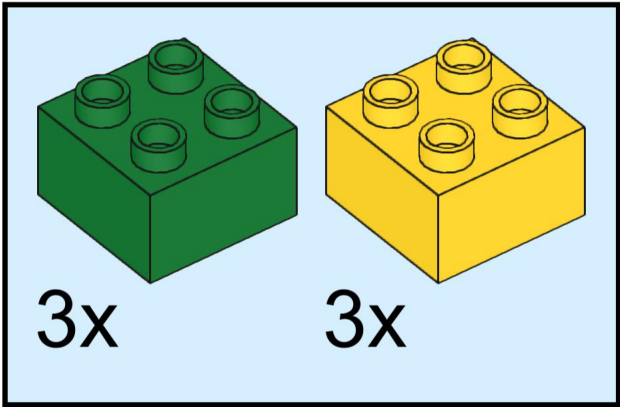

1

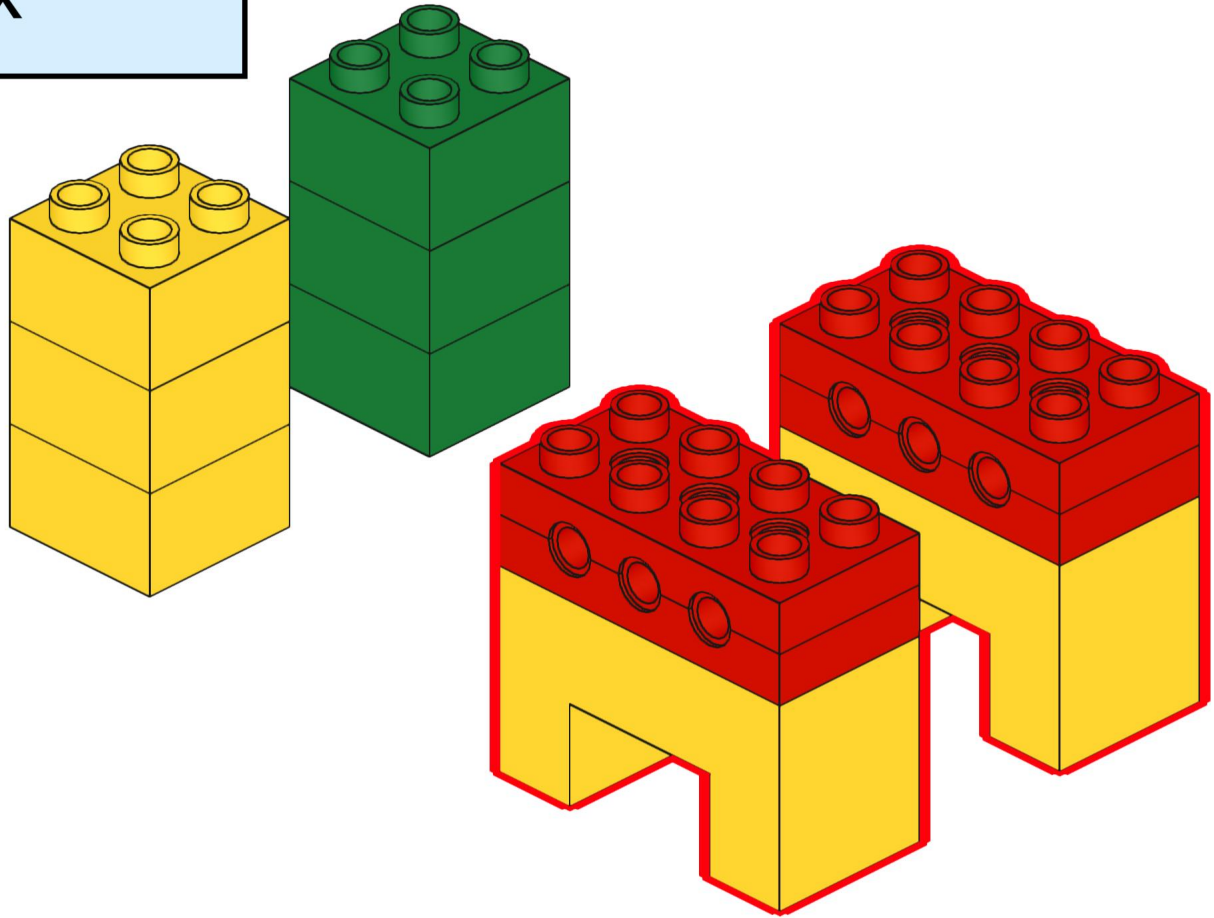
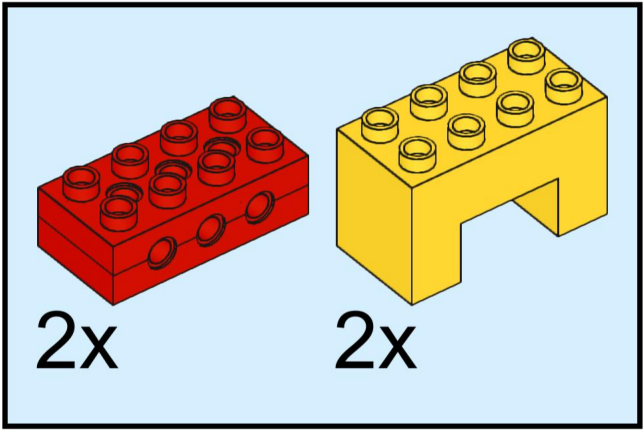

2

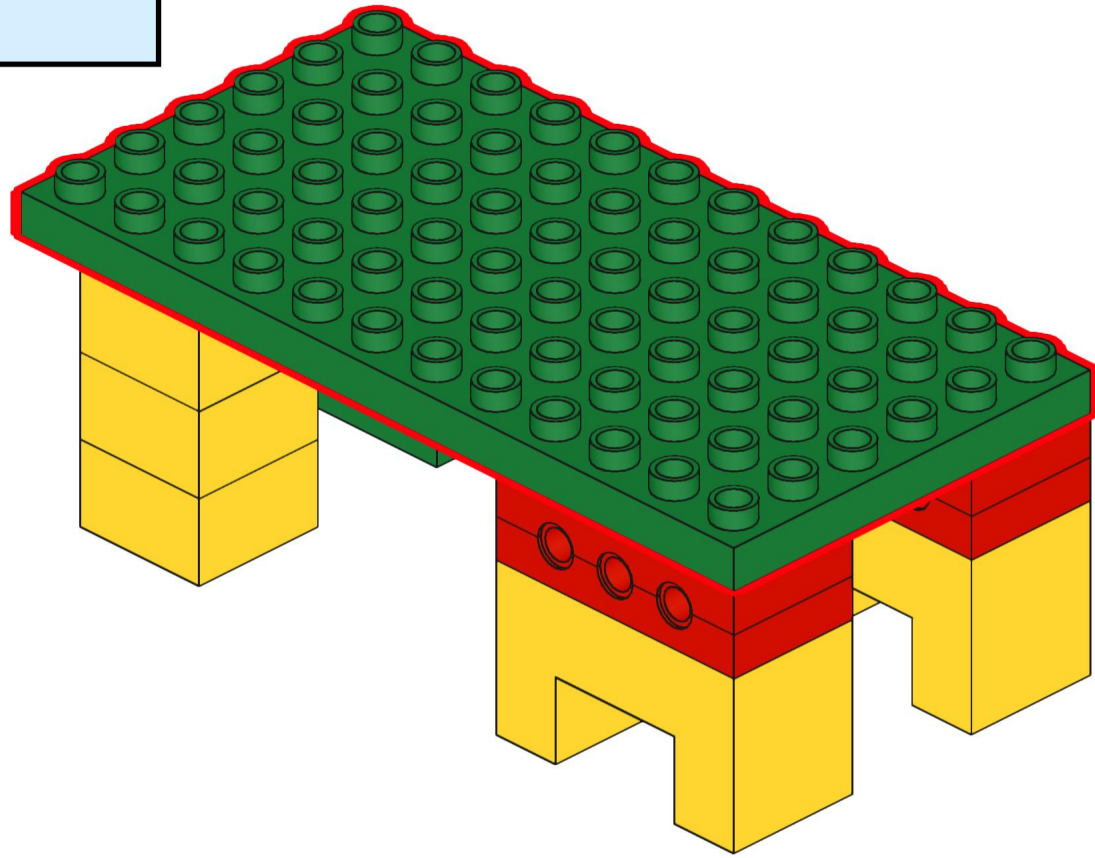
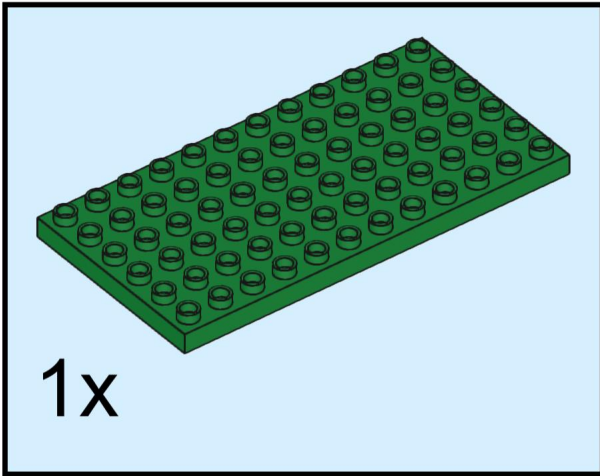

3

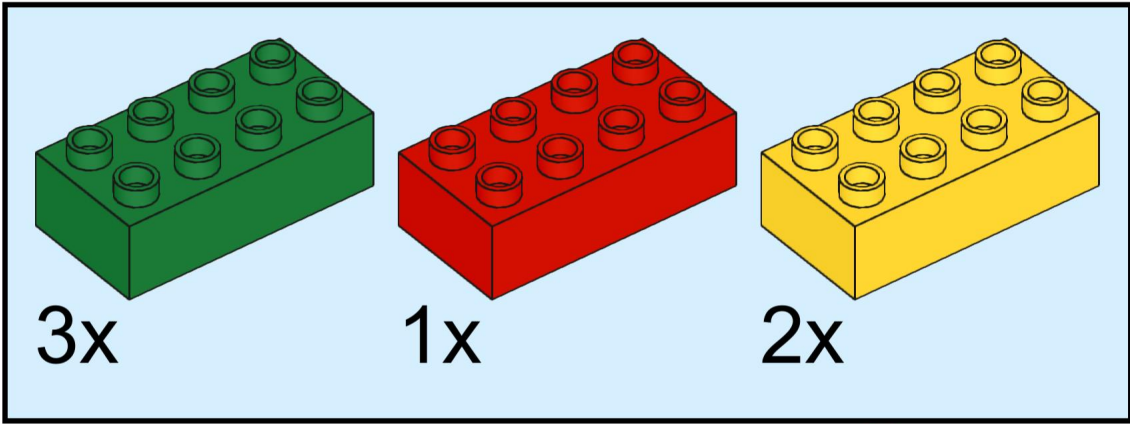

4

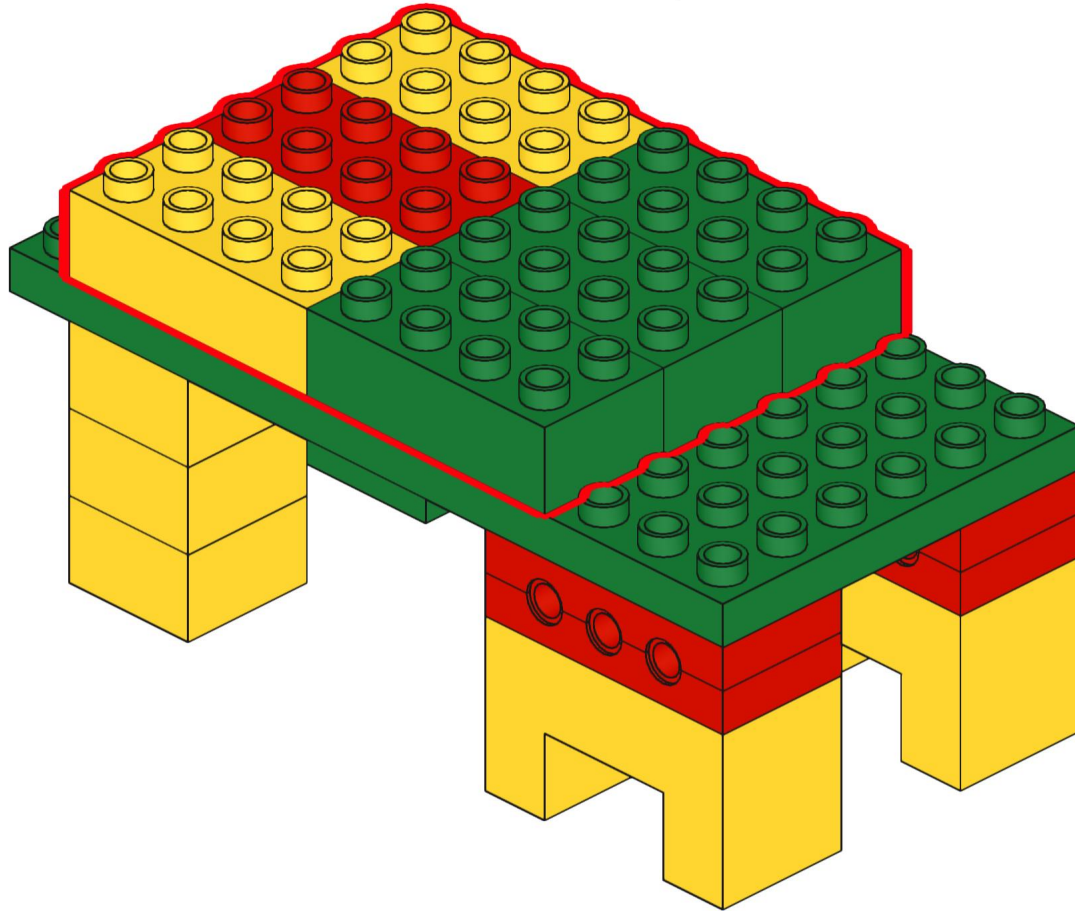

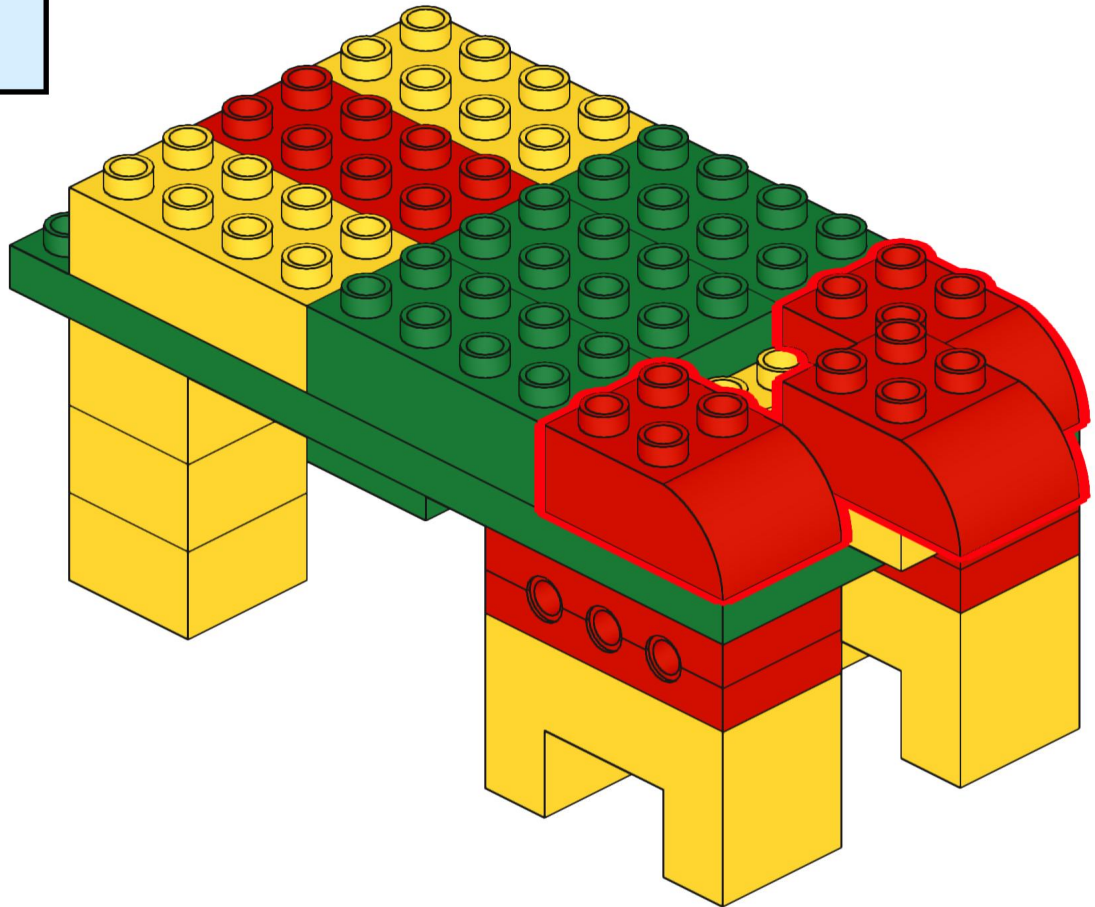
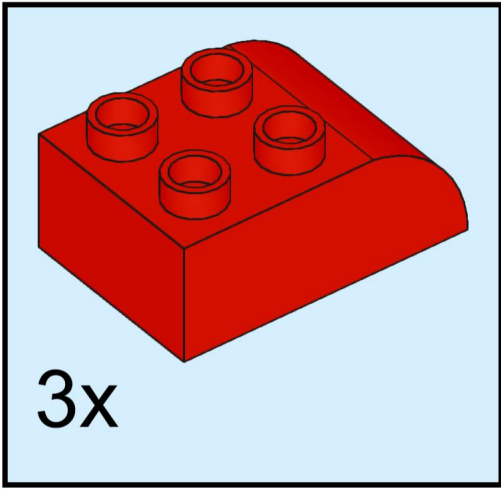

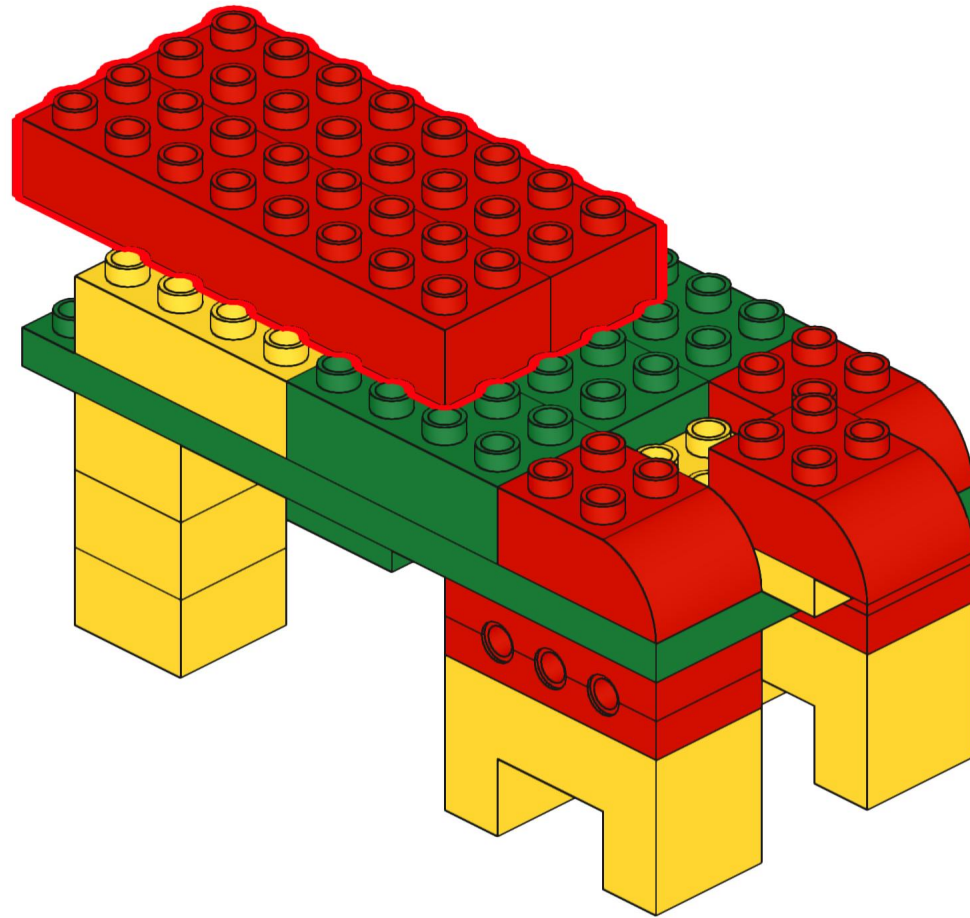
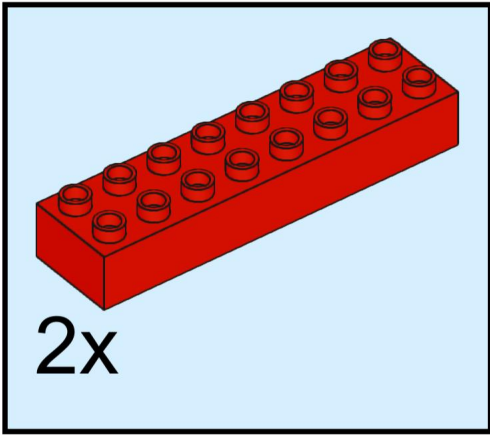

7

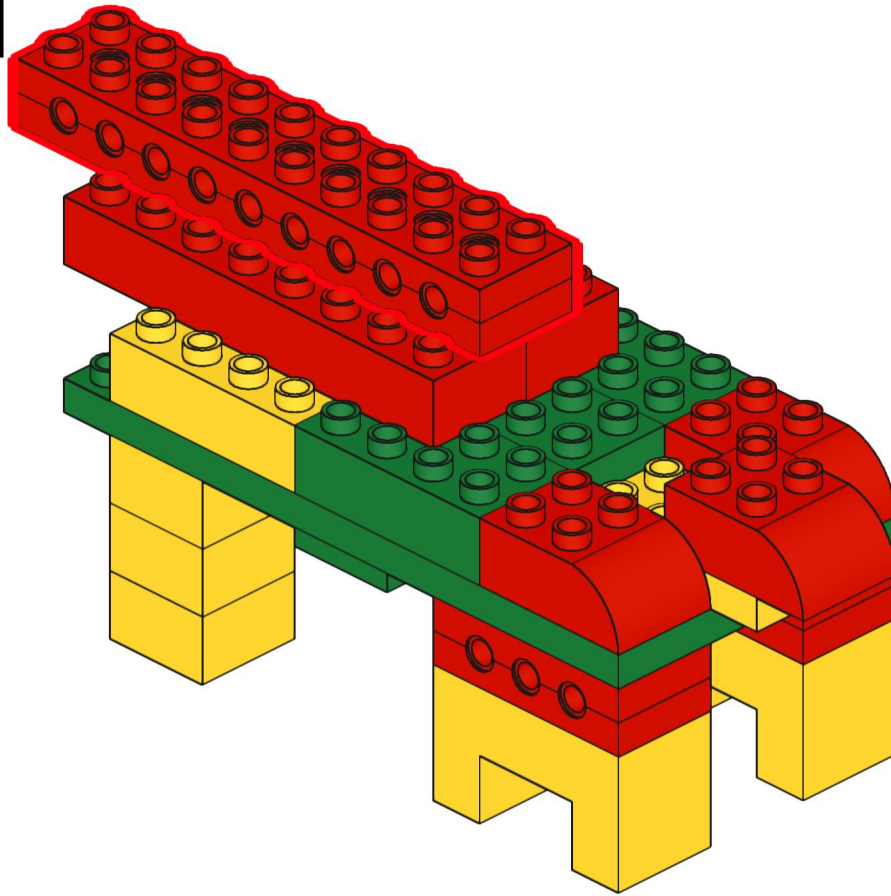
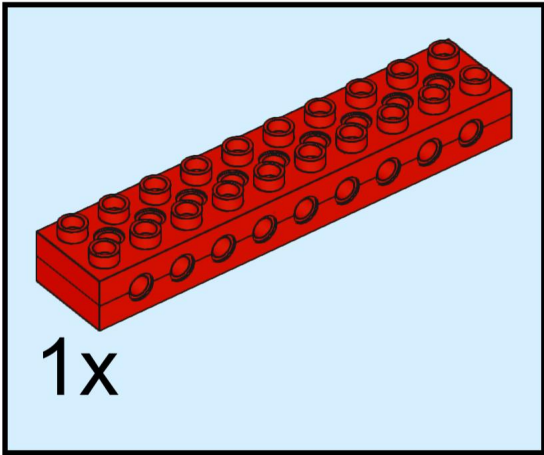

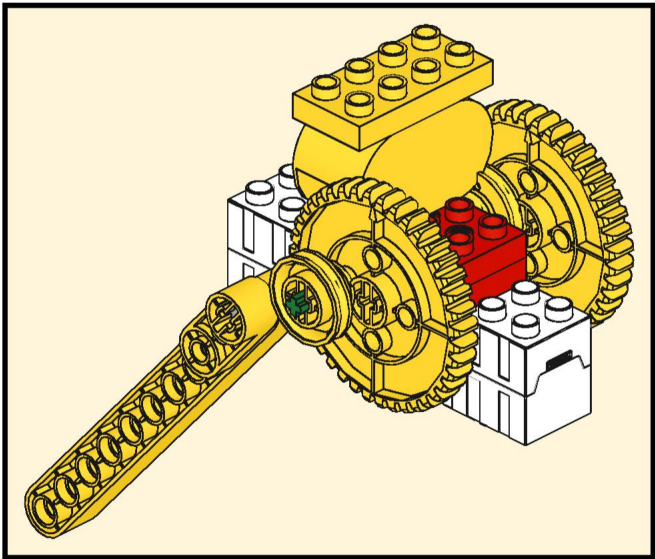
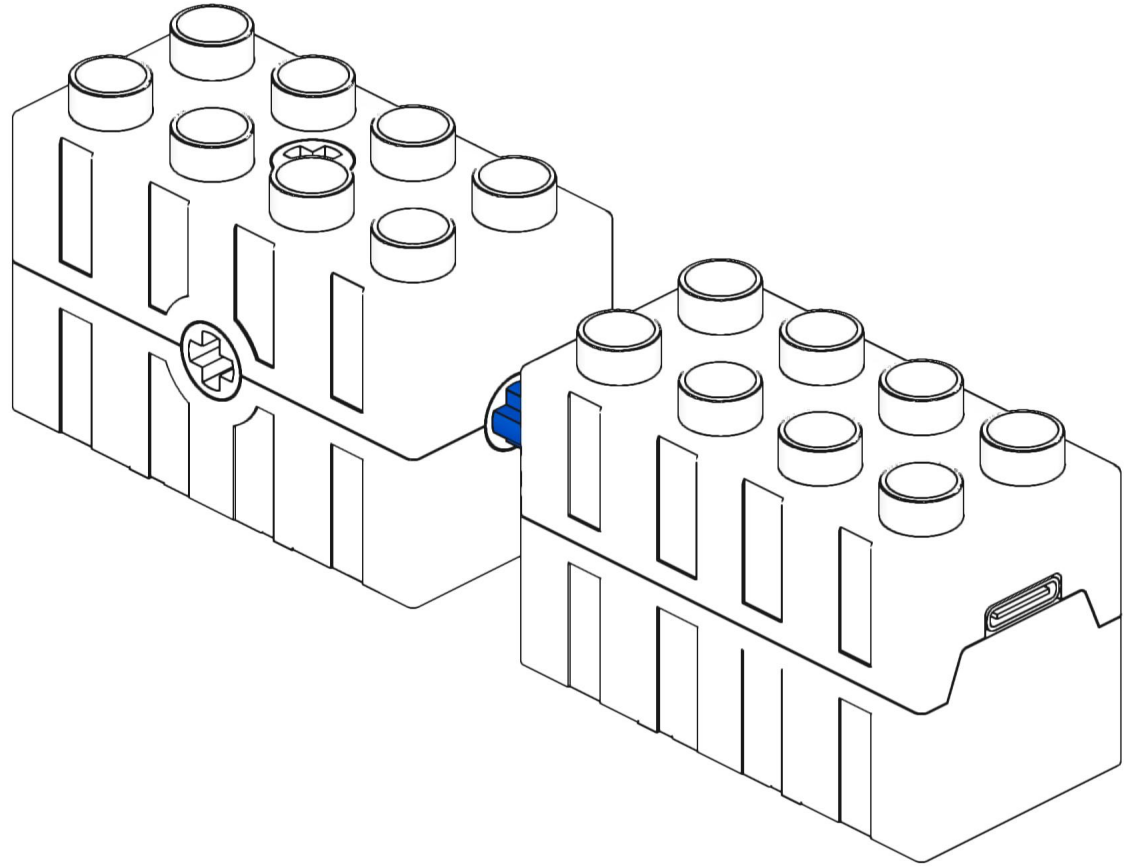
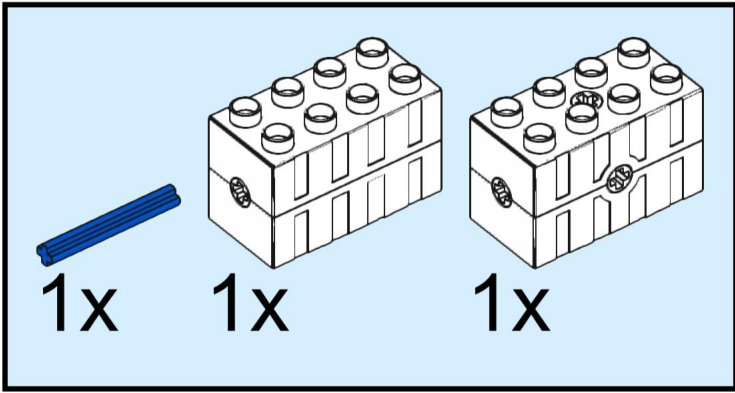

10

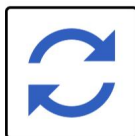
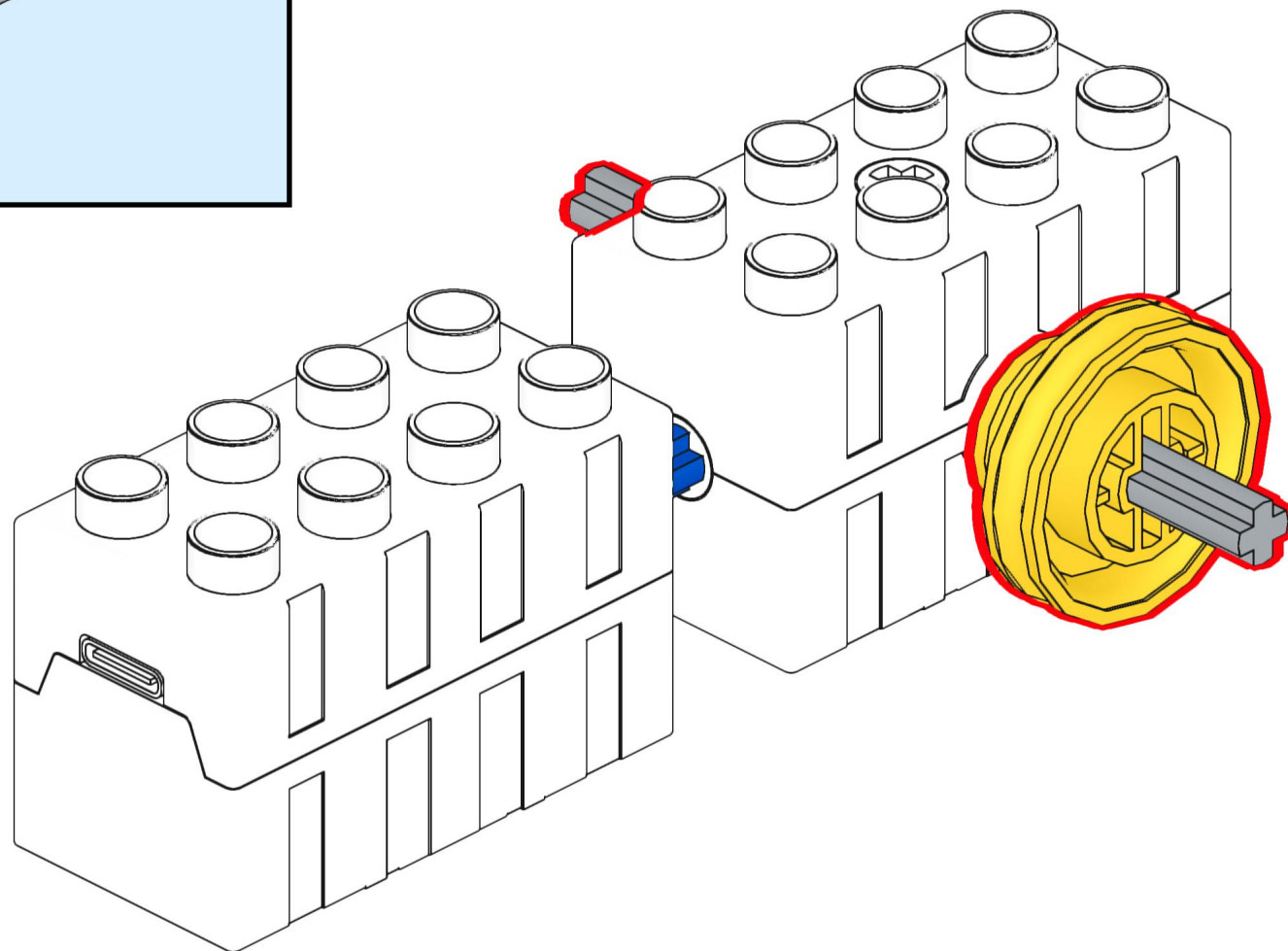
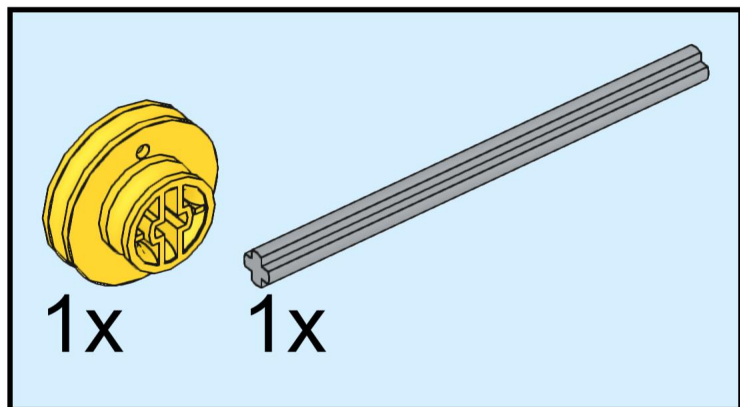

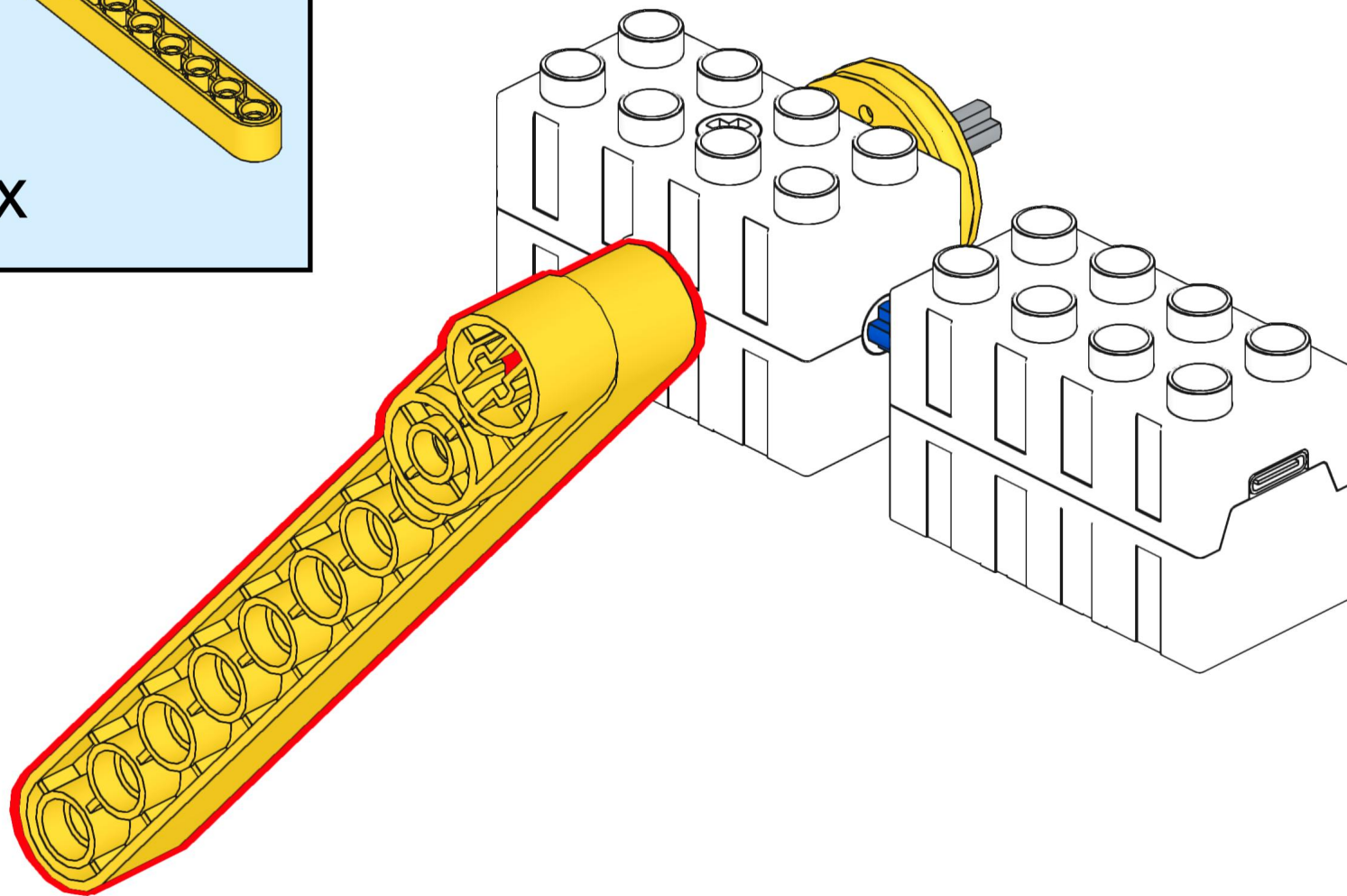
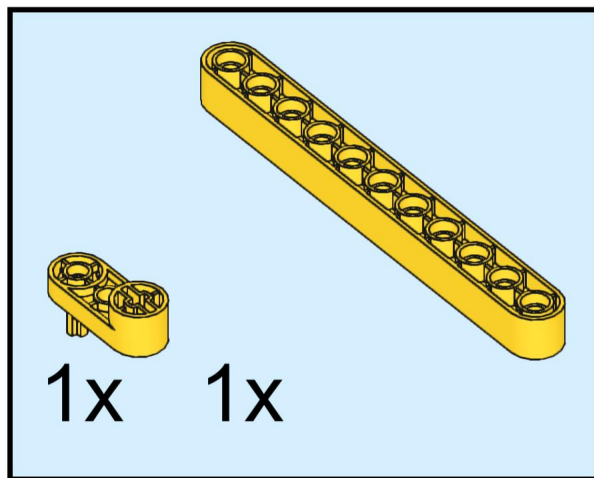

12

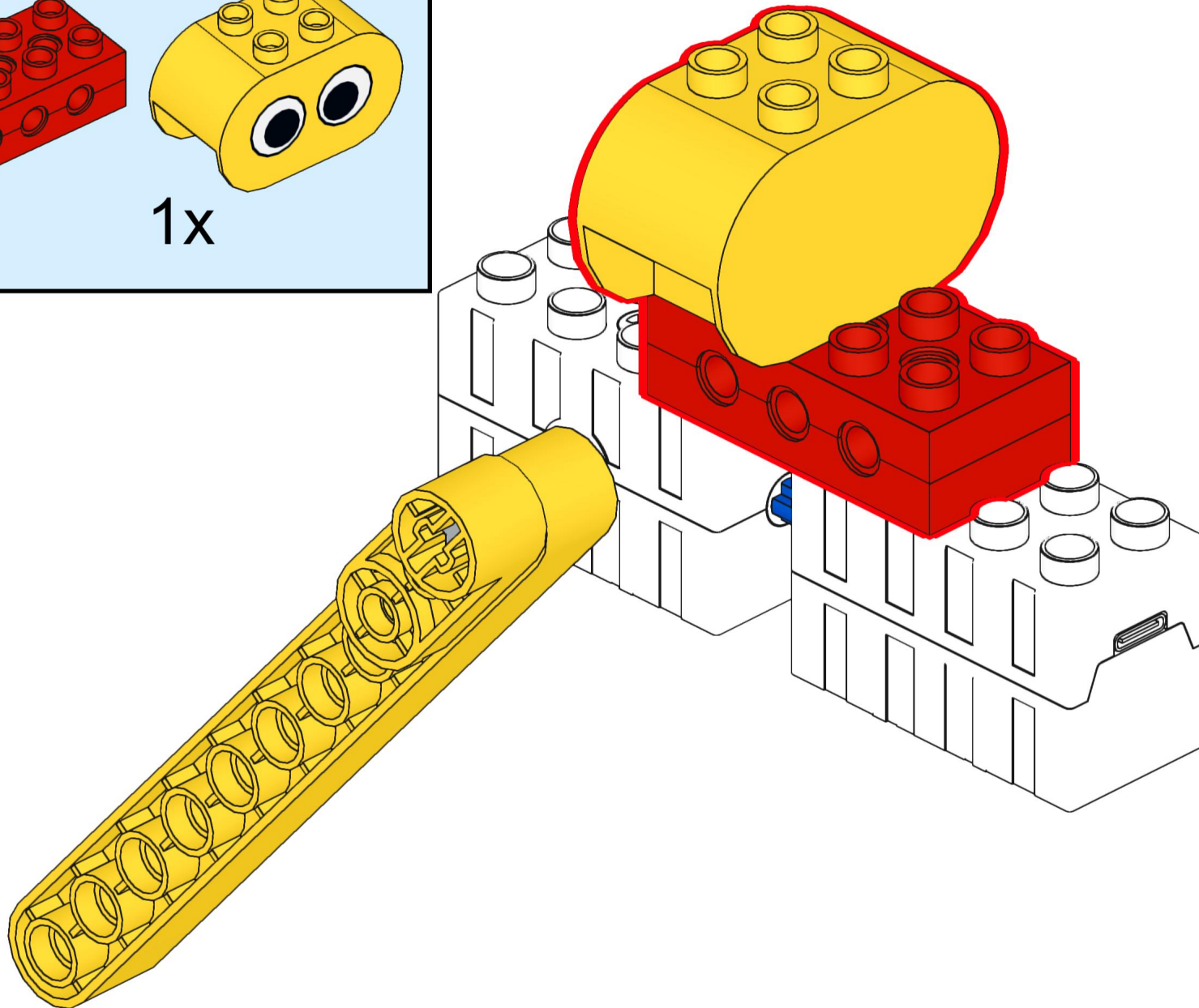
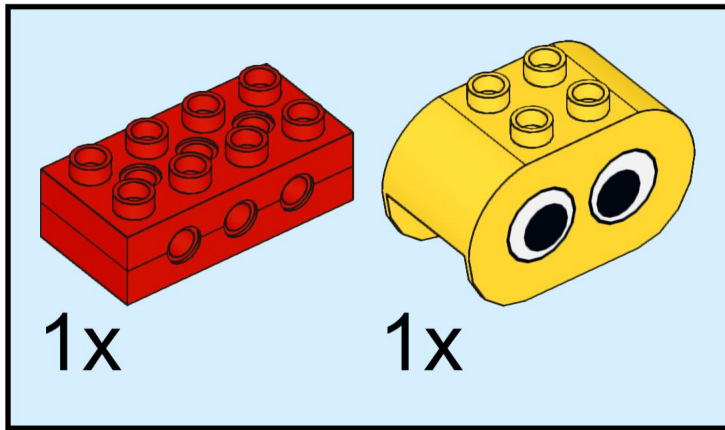

13

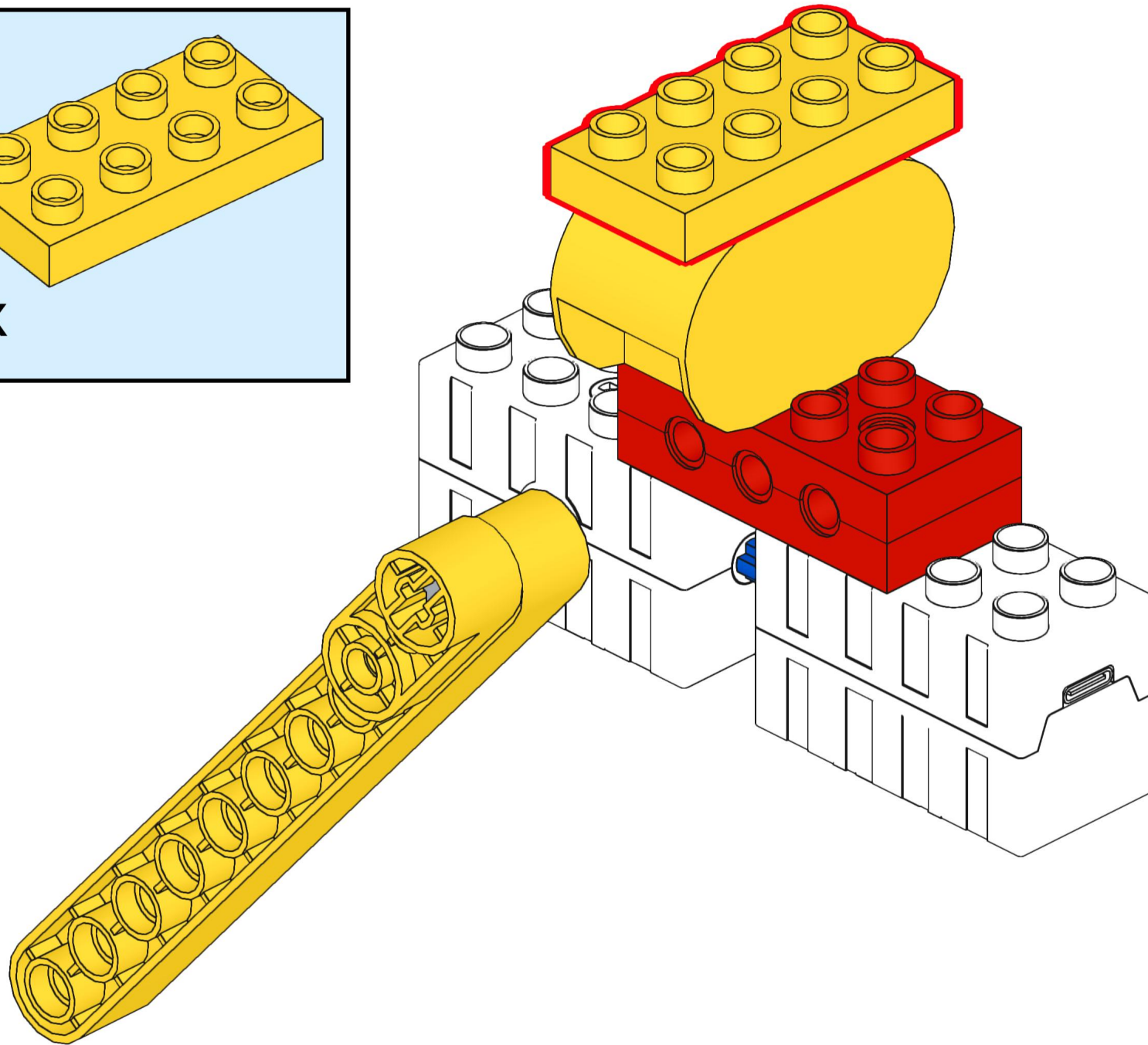
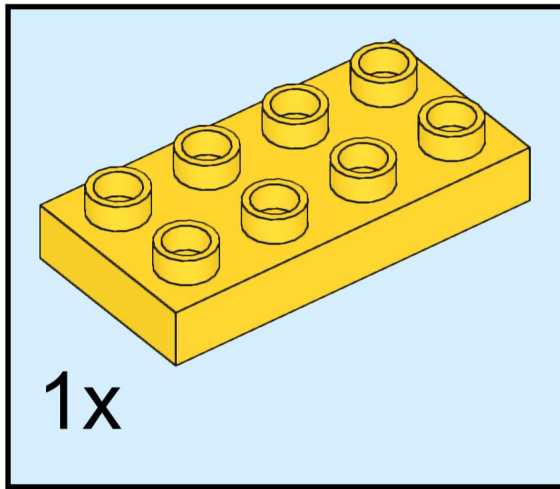

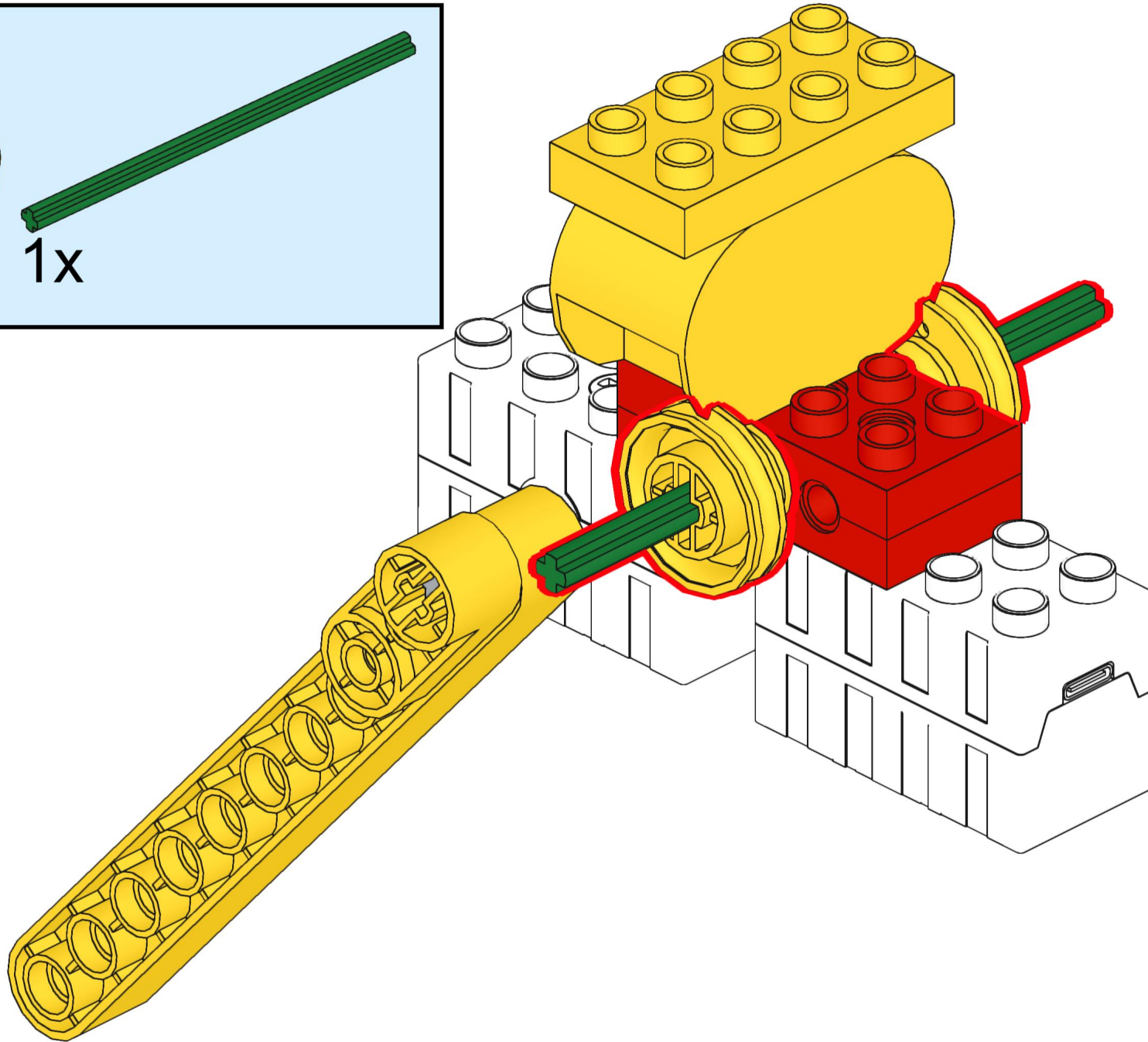
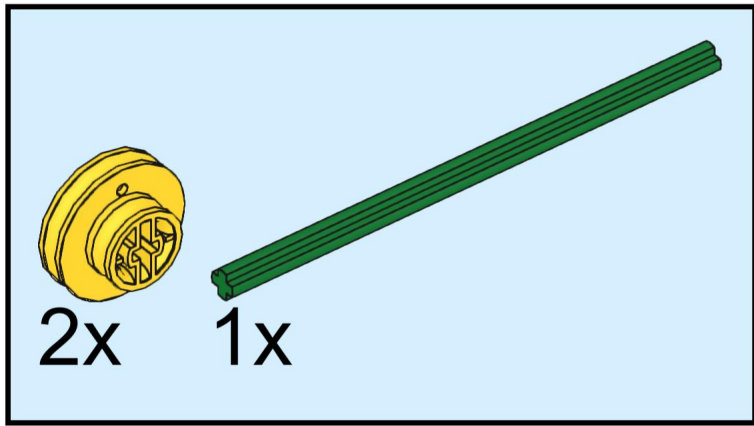

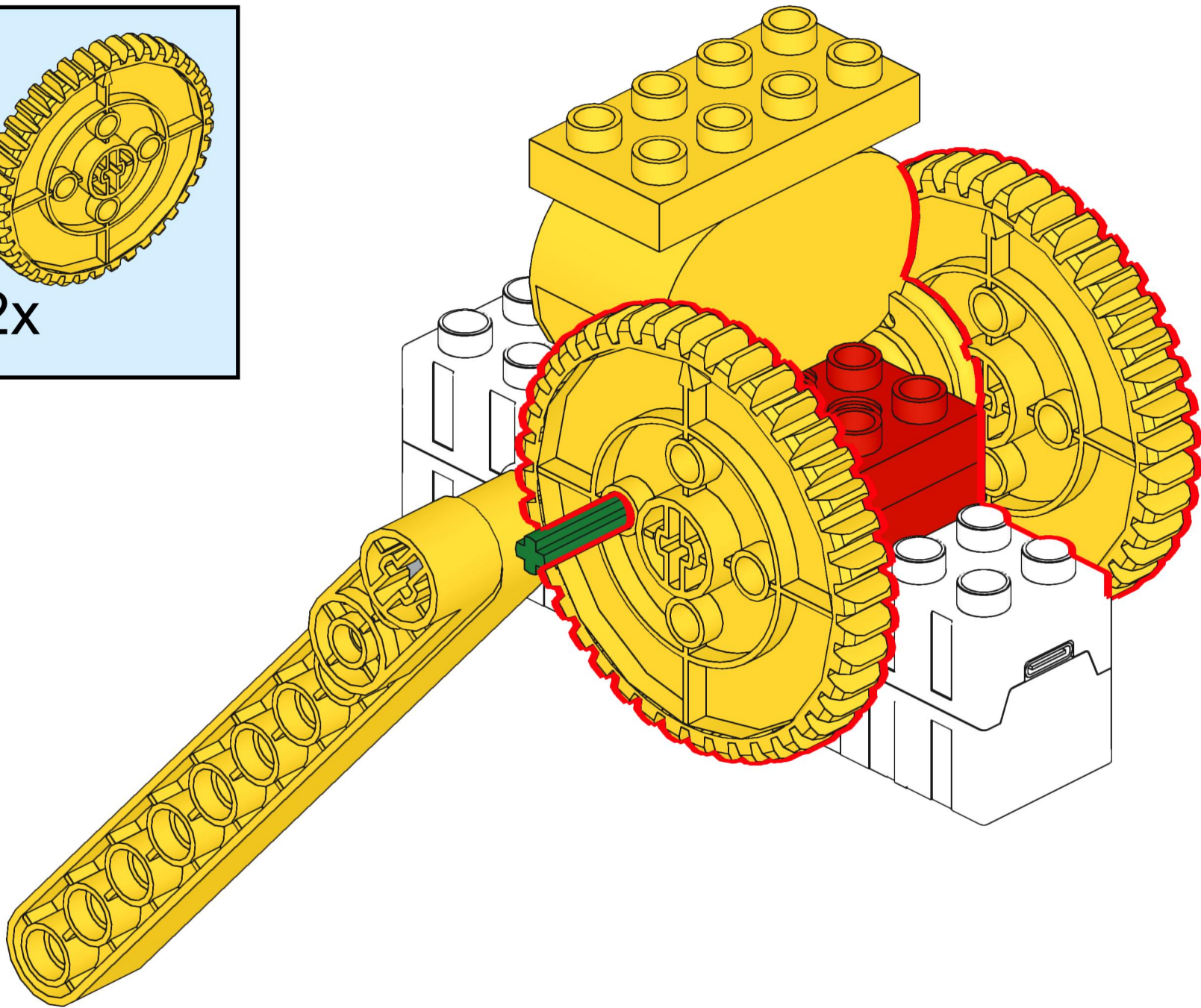
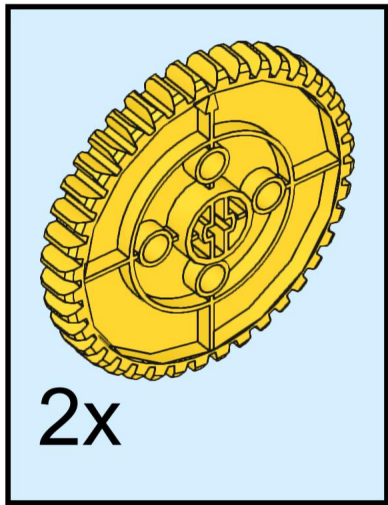

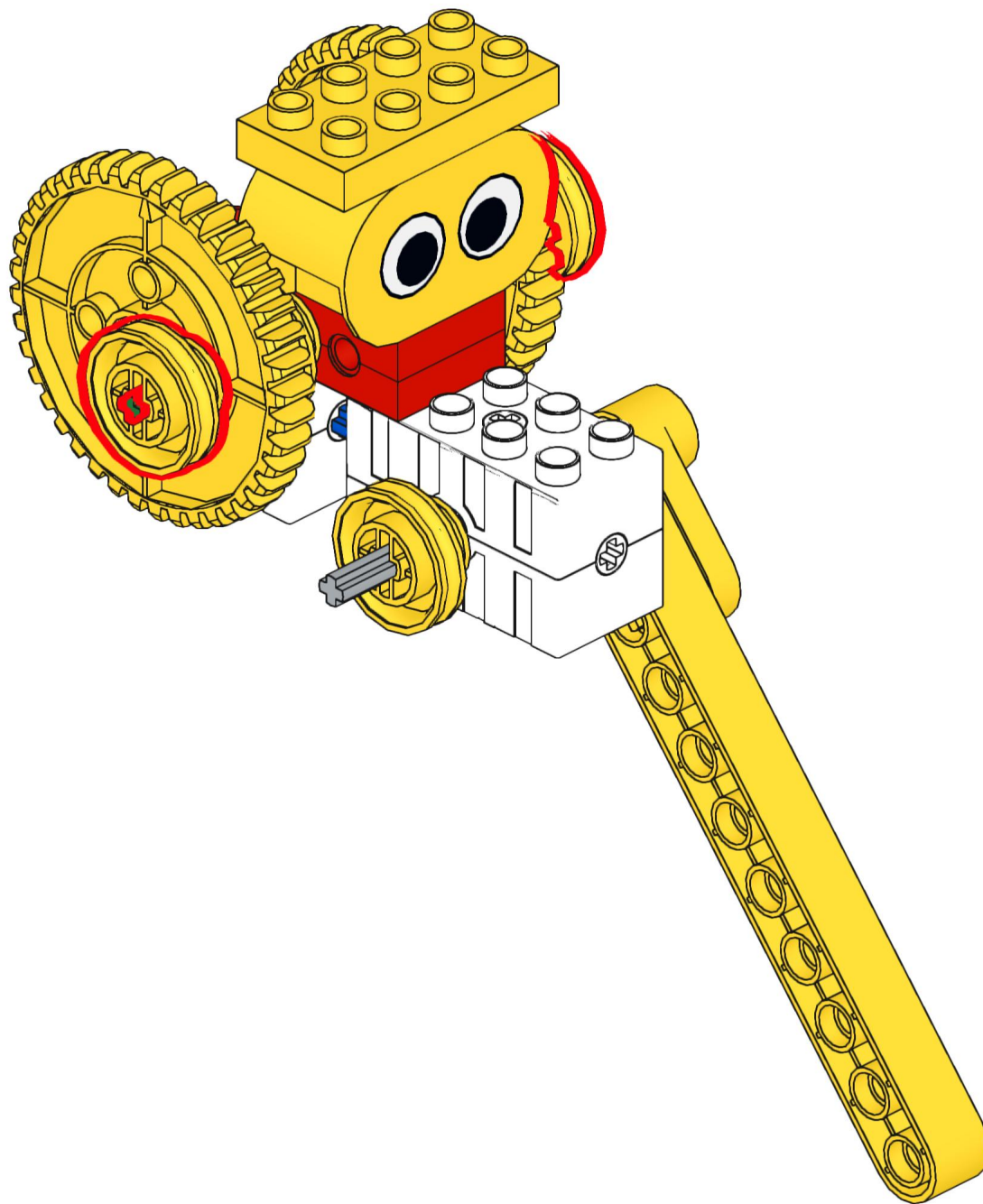
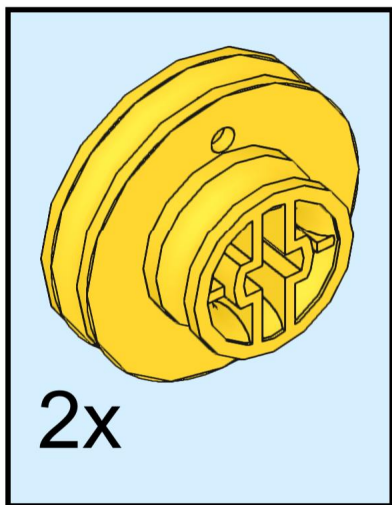

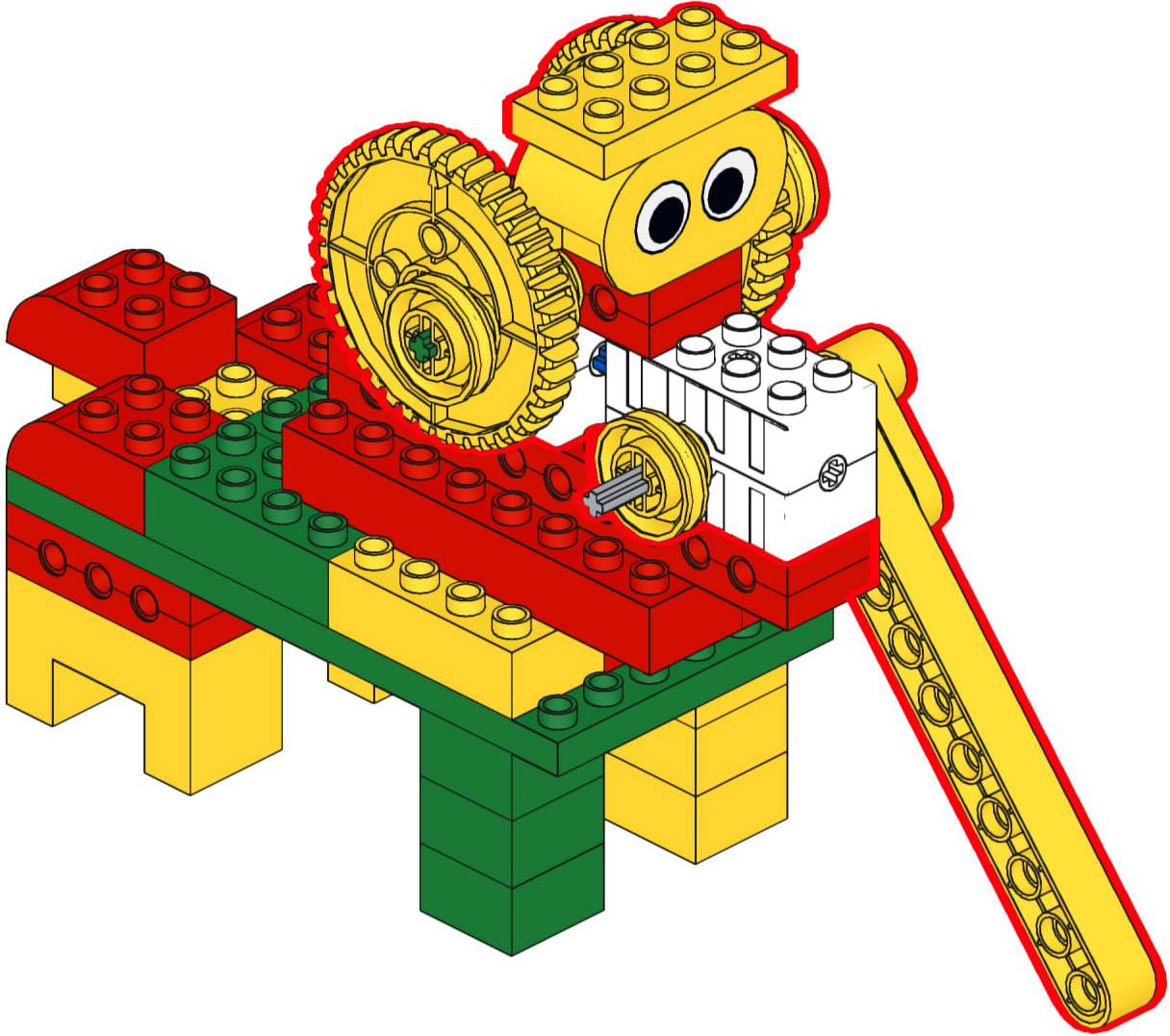

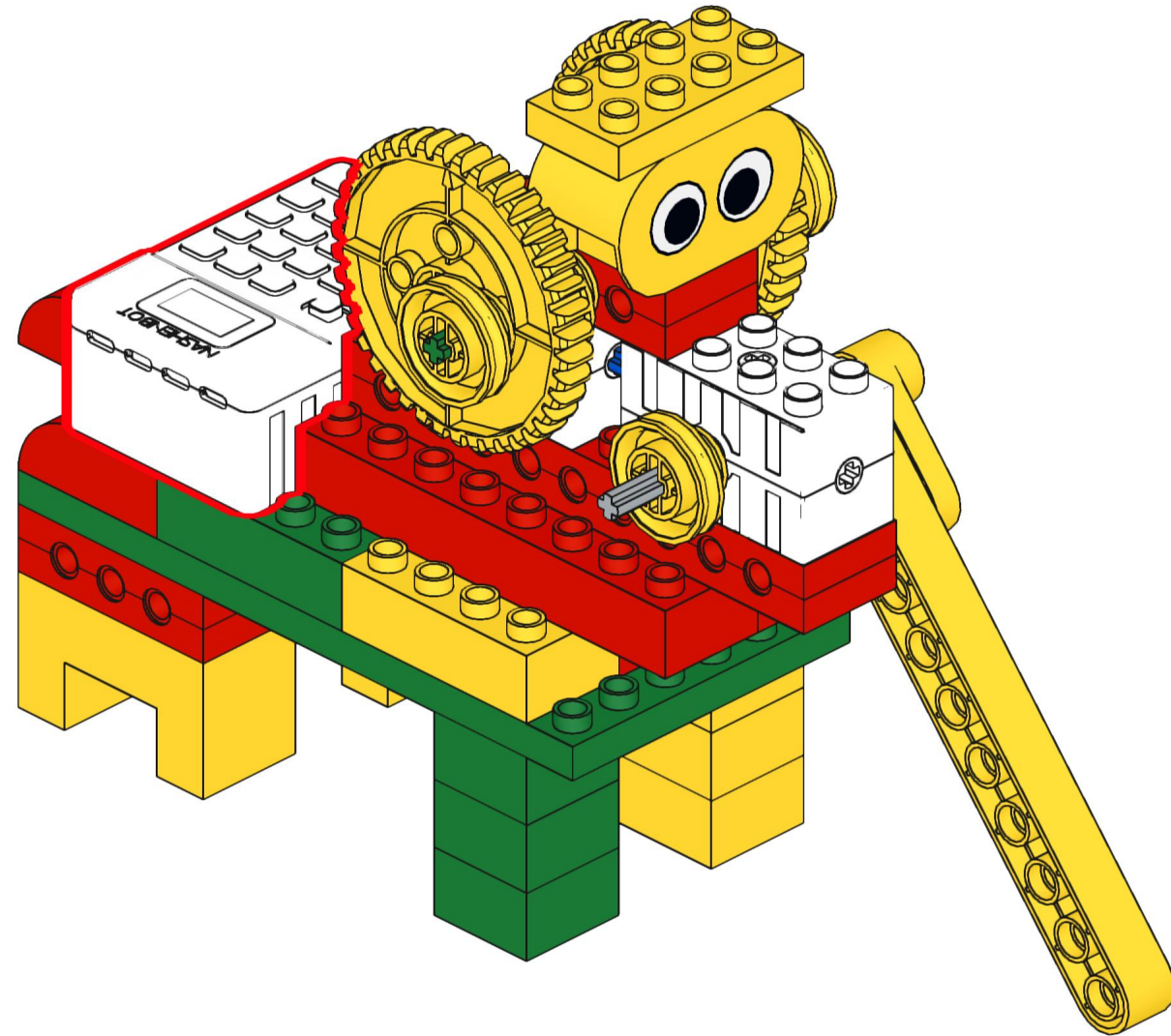
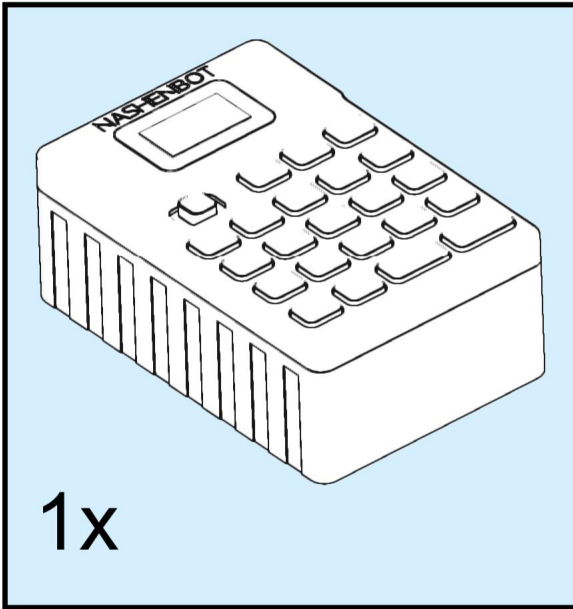

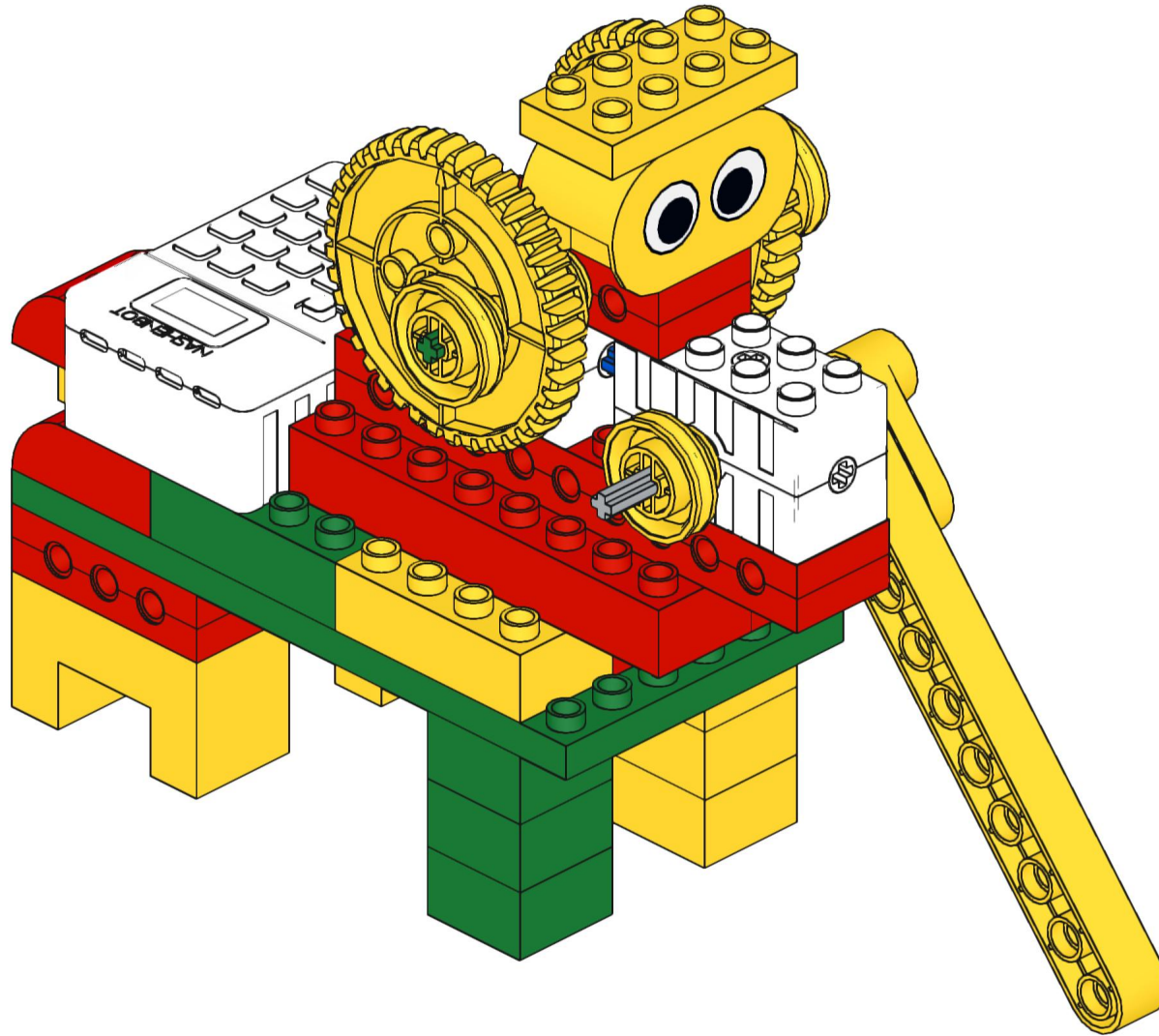

Website: www.nashenbot.com

E-mail: info@nashenbot.com

