



Principle structure

The diffused silicon sensor is used for differential pressure measurement. The signal is processed by a post-processing circuit and converted into a standard industrial electrical signal. The all-metal casing design, with a highlighted LED digital display, enables the product line to be used in a variety of industrial applications. The three-button design and menu make the product more convenient to use, and a variety of connection methods can fully meet various specific installation needs. The device, which can rotate at 330°, guarantees the best viewing Angle in different mounting modes.

Technical parameter

<ul style="list-style-type: none"> Supply voltage: 12... 30Vdc No-load current consumption: maximum 40mA, 24Vdc power supply Switch output: Output type: PNP/NPN can be switched, normally open/normally closed can be set Switching load: < 200mA /24VDC Response time: 0.01~2s (factory default) Switching accuracy: $\leq \pm 0.5\%$ range Current type analog output: $\leq \pm 0.5\%$ range Output type: 4-20mA/1-5V/0-10V Configurable Load RA: $\leq 500\Omega$ Linearity: $\leq 0.5\%$ range Communication output: IO-Link/RS485 Wiring protection: reverse phase, overload, short circuit protection Display: Design: Red 4-bit 12mm high brightness LED Display range: -1999... 9999 Accuracy: $\leq \pm 0.5\%$ range 	<ul style="list-style-type: none"> Stability (annual drift) : $\leq \pm 0.3\%$ range Temperature: Medium temperature: -20... 85°C Ambient temperature: -20... 80°C Storage temperature: -30... 80°C Overload capacity: unilateral overload full scale *2.5 times Bilateral synchronous pressure < 10MPa Material: Watch head housing: engineering plastic Flame retardant class: UL-94 V-0 Housing: stainless steel 304 Medium contact part: stainless steel 304 Protection grade: IP67 Outlet: M12x1 connector
---	---

Panel diagram

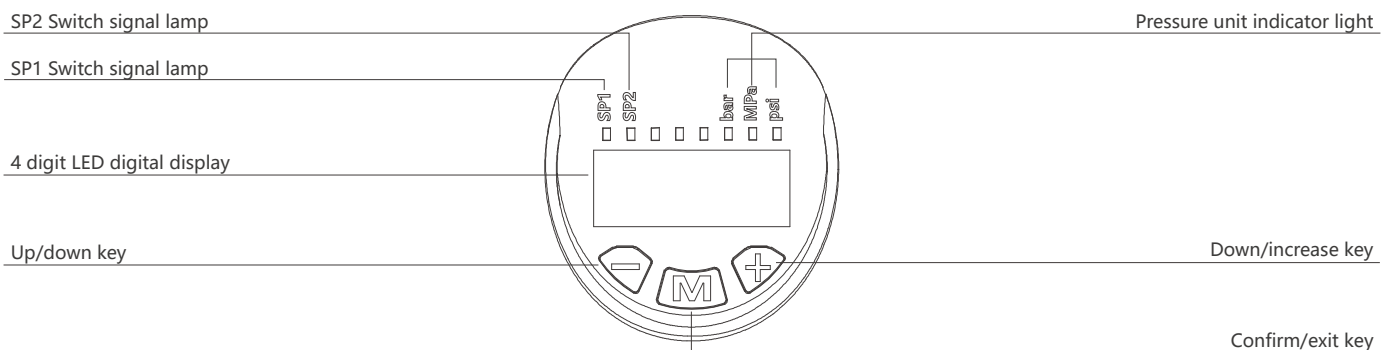

Wiring diagram

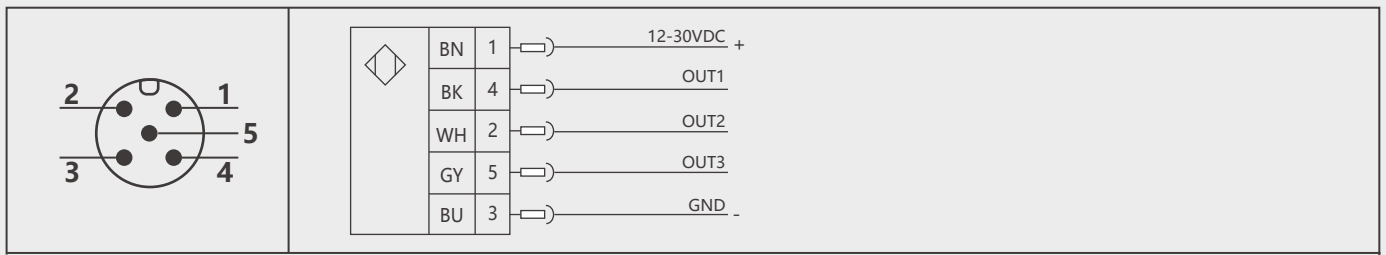

A3: Two way switch + one way analog

color	stitch	Instructions	color	stitch	Instructions	color	stitch	Instructions
BN	1	power supply (+)	BU	3	power supply (-)	GY	5 (OUT3)	4-20mA (Factory default) 1-5V 0-10V
BK	4 (OUT1)	SP1 switch PNP (Factory default) SP1 switch NPN	WH	2 (OUT2)	SP2 switch PNP (Factory default) SP2 switch NPN			

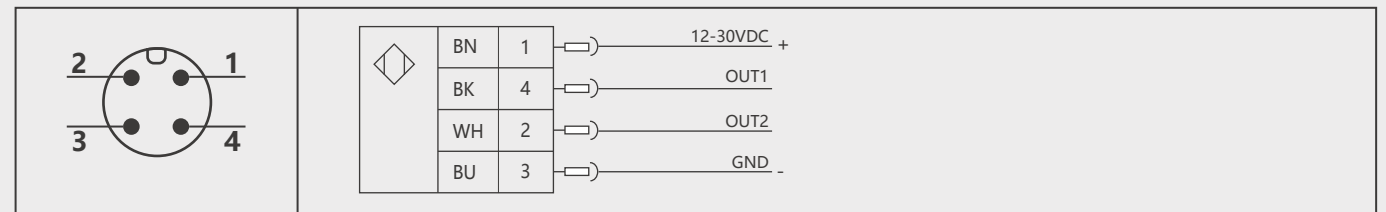

S2: Two-way switch/IO-Link

color	stitch	Instructions	color	stitch	Instructions
BN	1	power supply (+)	BU	3	power supply (-)
BK	4 (OUT1)	SP1 switch PNP (Factory default) SP1 switch NPN IO-Link	WH	2 (OUT2)	SP2 switch PNP (Factory default) SP2 switch NPN

SA: One switch /IO-Link + analog

color	stitch	Instructions	color	stitch	Instructions
BN	1	power supply (+)	BU	3	power supply (-)
BK	4 (OUT1)	SP1 switch PNP (Factory default) SP1 switch NPN IO-Link	WH	2 (OUT2)	4-20mA (Factory default) 1-5V 0-10V

RS: RS485

color	stitch	Instructions	color	stitch	Instructions
BN	1	power supply (+)	BU	3	power supply (-)
BK	4 (OUT1)	RS485(B)	WH	2 (OUT2)	RS485(A)

Dimensional drawing (mm)

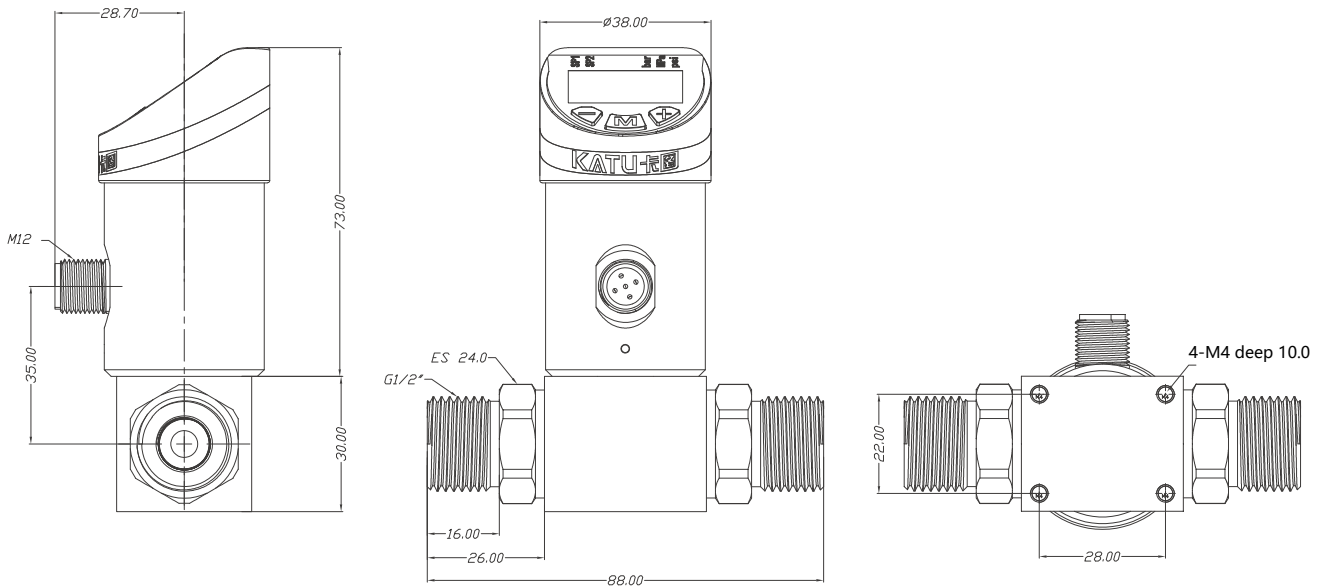

Selection table

PS510-	001	G14K	G14K	S2	expatiate
PS510					PS510 series electronic digital differential pressure sensor
	001				Setting range: 0... 0.1 bar
	002				Setting range: 0... 0.2 bar
	005				Setting range: 0... 0.5 bar
	010				Setting range: 0... 1bar
	050				Setting range: 0... 5bar
	060				Setting range: 0... 6bar
	100				Setting range: 0... 10bar
	160				Setting range: 0... 16bar
	250				Setting range: 0... 25bar
		G14K			H High voltage end interface thread: G1/4 internal thread
		G14M			H High voltage end interface thread: G1/4 external thread
		G12M			H High voltage end interface thread: G1/2 external thread
		M20M			H High voltage end interface thread: M20*1.5 external thread
			G14K		L Low pressure end interface thread: G1/4 internal thread
			G14M		L Low pressure end interface thread: G1/4 external thread
			G12M		L Low pressure end interface thread: G1/2 external thread
			M20M		L Low pressure end interface thread: M20*1.5 external thread
				S2	Output signal: Two switch output/IO-link (4-core cable)
				SA	Output signal: One switch output /IO-link + analog output (4-core cable)
				A3	Output signal: two switch output + analog output (5-core cable)
				RS	Output signal: RS485 communication (4-core cable)

Optional accessories - Electrical accessories (M12-5Pin: Factory default ZL05-PC02G)

name	Outline drawing/dimension drawing (unit :mm)	material	Model number	Shielded wire	M12*1-4Pin/5Pin self-connector/Dimensions (Unit:mm)	Model number		
M12*1-5Pin (2m cable)		PUR	ZL05-PU02G	-P		GL04 (4 Pin connector)		
M12*1-5Pin (5m cable)			ZL05-PU05G			GL05 (4 Pin connector)		
M12*1-5Pin (10m cable)			ZL05-PU010G					
M12*1-5Pin (2m cable)		PVC	ZL05-PC02G				WL04 (4 Pin connector)	
M12*1-5Pin (5m cable)			ZL05-PC05G					WL05 (5 Pin connector)
M12*1-5Pin (10m cable)			ZL05-PC010G					
M12*1-5Pin (2m cable)		PUR	ZL05-PU02W		-P			WL04 (4 Pin connector)
M12*1-5Pin (5m cable)			ZL05-PU05W					
M12*1-5Pin (10m cable)			ZL05-PU010W					
M12*1-5Pin (2m cable)		PVC	ZL05-PC02W					WL04 (4 Pin connector)
M12*1-5Pin (5m cable)			ZL05-PC05W	WL05 (5 Pin connector)				
M12*1-5Pin (10m cable)			ZL05-PC010W					

Optional accessories - Electrical accessories (M12-4Pin: Factory default ZL04-PC02G)

name	Outline drawing/dimension drawing (unit :mm)	material	Model number	Shielded wire		
M12*1-4Pin (2m cable)		PUR	ZL04-PU02G	-P		
M12*1-4Pin (5m cable)			ZL04-PU05G			
M12*1-4Pin (10m cable)			ZL04-PU010G			
M12*1-4Pin (2m cable)		PVC	ZL04-PC02G			
M12*1-4Pin (5m cable)			ZL04-PC05G			WL04 (4 Pin connector)
M12*1-4Pin (10m cable)			ZL04-PC010G			
M12*1-4Pin (2m cable)		PUR	ZL04-PU02W			-P
M12*1-4Pin (5m cable)			ZL04-PU05W			
M12*1-4Pin (10m cable)			ZL04-PU010W			
M12*1-4Pin (2m cable)		PVC	ZL04-PC02W			
M12*1-4Pin (5m cable)			ZL04-PC05W	WL04 (4 Pin connector)		
M12*1-4Pin (10m cable)			ZL04-PC010W			

Optional accessories - Protective cover

500 Series(sensor) Sensor protection cover

Order number: KTCS33662

—— Sensor and controller ——

- Flow
- pressure
- temperature
- level
- position

KATU 卡图

Operation instruction

Electronic pressure sensor

500 series

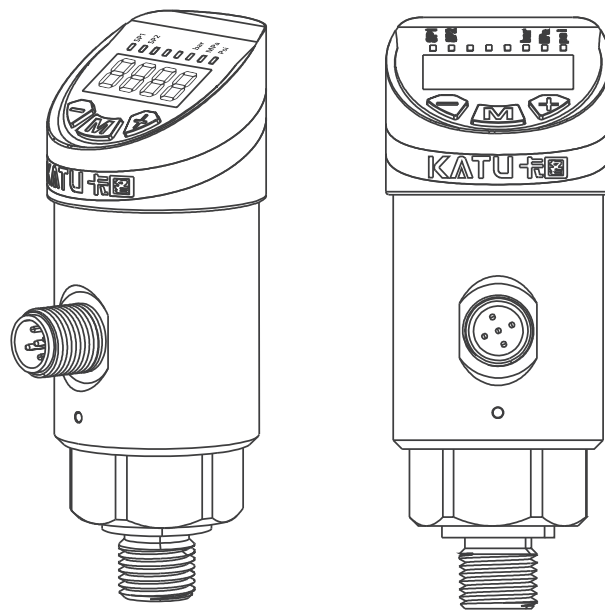

Purpose of product application

The 500 Series sensor (switch) has two switch outputs and one analog output.



danger

The sensor (switch) can only be used in the specified application range.

The temperature range must be within the permissible range. Do not exceed the rated pressure and power load value.

Assembly, commissioning and operation must be carried out in accordance with applicable national and local safety instructions.

The switch is designed to be used as a safety device for pressurizing the system in accordance with "Pressure Equipment Directive 97/23 / EC(PED)".

Standard

The standards applied during development, manufacturing and configuration are listed in the CE Compliance and manufacturer declarations.

Quality assurance

Our scope of delivery and service is subject to legal warranties and warranty periods.

Warranty clause

We guarantee that the functions and materials of the dual pressure switch meet the statutory requirements under normal operation and maintenance conditions.

Security of loss

Such as:

- Incorrect use,
- Incorrect installation
- Incorrect operation or operation in violation of the provisions of this operation manual.

No liability shall be assumed for any damage resulting therefrom or consequential.

Safety instruction

Safety instructions are intended to protect users from dangerous situations and /or prevent material damage.

In the operating instructions, the severity of the potential risk can be indicated by the following signal words:



danger

An imminent danger to the user. Failure to comply may result in fatal injury.



warning

An identifiable hazard.

Failure to comply may result in fatal injury and damage to equipment or plant parts.



caution

It means a danger.

Non-compliance may result in minor injury and material damage to the sensor (switch) and/or plant.



important

Information that is important to the user.



Deal with

Sensors (switches) must be handled correctly in accordance with national or local regulations for electrical/electronic equipment.

Sensors (switches) cannot be disposed of with household waste!

Product characteristics

The all-metal casing design, with a highlighted LED digital display, enables the product line to be used in a variety of industrial applications. The three-button design and menu make the product more convenient to use, and a variety of connection methods can fully meet various specific installation needs. The device, which can rotate at 330°, guarantees the best viewing Angle in different mounting modes.

Switching function

If the switch is higher or lower than the set switching limit (SP, rP), its switching state is changed. The following switch functions can be selected:

- Hysteresis function normally open: = [Hno] (→ Figure 1)
- Hysteresis function normally closed: = [Hnc] (→ Figure 1)

First set the switch point: (SP), Then set the reset point: (rP).

If SP changes again, the hysteresis will change with it.

- Window function usually open: = [Fno] (→ Figure 2)
- Window function normally closed: = [Fnc] (→ Figure 2)

The width of the window can be set by the difference between SP and rP.

SP = Upper limit value, rP = Lower limit value.

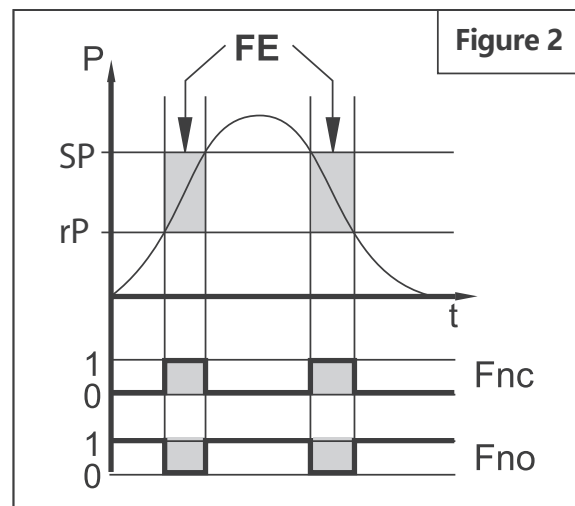
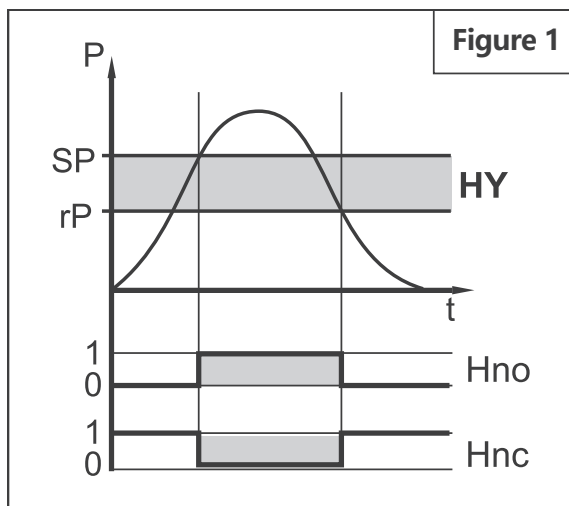

P = System pressure; HY = lag; FE = window

Install

Safety instructions are intended to protect users from dangerous situations and/or prevent material damage. In the operating instructions, the severity of the potential risk can be indicated by the following signal words:



caution

Vibration and violent vibration must be avoided during transportation. Even if the sensor (switch) housing is not damaged, Internal components can also break down and cause failure.



danger

Sensors (switches) should only be installed in systems that do not exceed the maximum pressure P_{max} (see type label).
Install sensors (switches) only when power is off (electric, hydraulic/pneumatic).

! Ensure that the system is under any pressure before installing or removing the sensor.

- Connect the sensor device to the selected process port
- Fully tighten, recommended tightening torque range: 25 to 35Nm
- In critical applications (such as violent vibrations or shocks), the pressure pipe joint can be mechanically decoupled via a miniature hose.

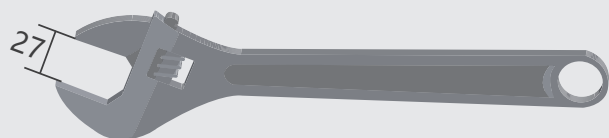
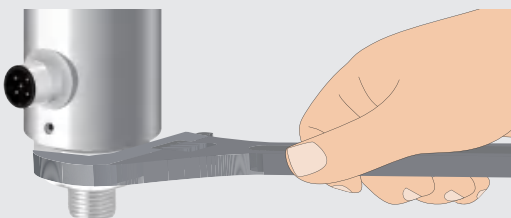

Panel description

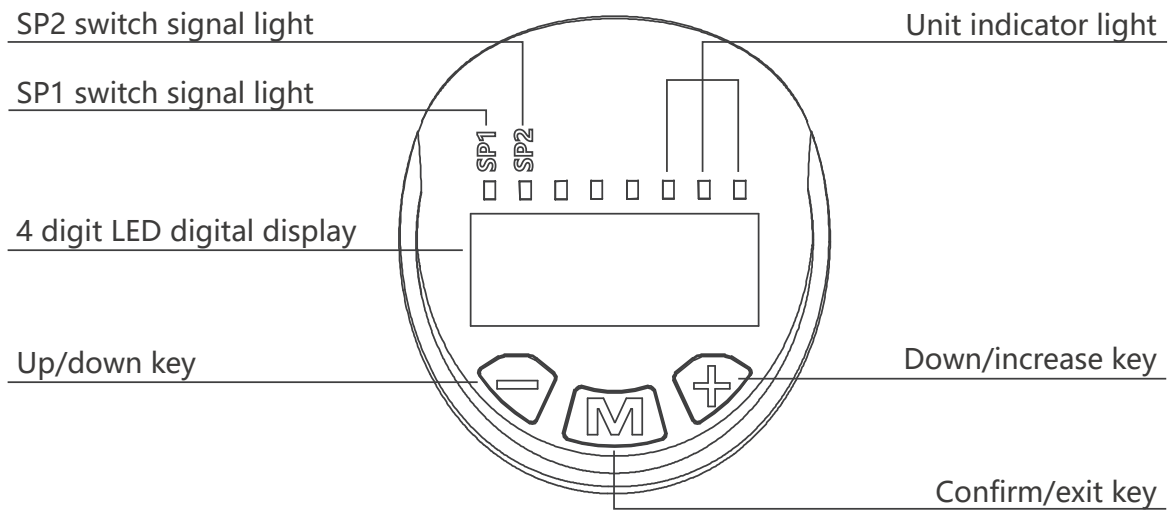

Electrical connection (Standard type)

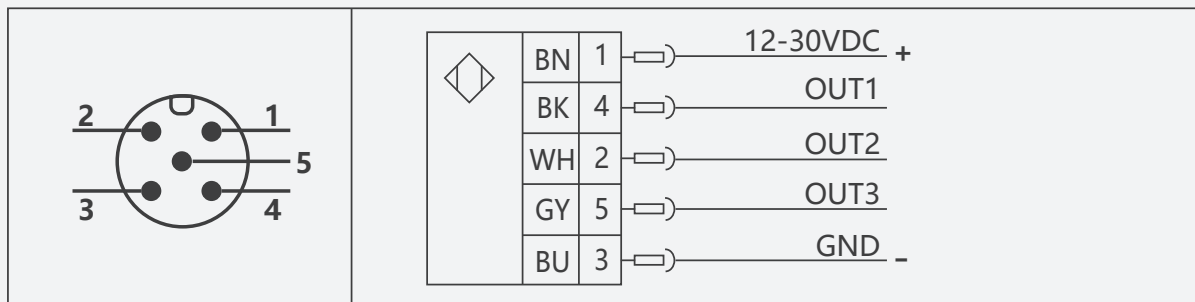

A3: Two-way switch + one-way analog

color	stitch	Instructions
BN	1	power supply (+)
BU	3	power supply (-)
BK	4 (OUT1)	SP1 Switch PNP (factory default) SP1 Switch NPN
WH	2 (OUT2)	SP2 Switch PNP (factory default) SP2 Switch NPN
GY	5 (OUT3)	4-20mA (factory default) 1-5V 0-10V

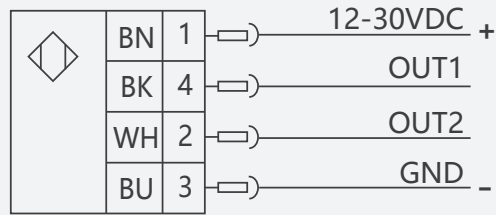
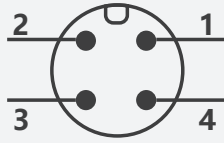

S2: Two way switch/IO-Link

color	stitch	Instructions
BN	1	power supply (+)
BU	3	power supply (-)
BK	4 (OUT1)	SP1 Switch PNP (factory default) SP1 Switch NPN IO-Link
WH	2 (OUT2)	SP2 Switch PNP (factory default) SP2 Switch NPN

SA: One switch /IO-Link + one analog

color	stitch	Instructions
BN	1	power supply (+)
BU	3	power supply (-)
BK	4 (OUT1)	SP1 Switch PNP (factory default) SP1 Switch NPN IO-Link
WH	2 (OUT2)	4-20mA (factory default) 1-5v 0-10v

Debugging/operation

Sensors can only be debugged and operated by authorized personnel.



caution

Do not put the switch into operation when the sensor itself or the connecting cable is damaged.

Do not use any sharp, hard objects to make entries. The key may be damaged by something sharp and hard.



warning

Note that the casing surface may become very hot if the operating temperature is high!

Level 1 menu		
	Alarm value of Switch 1 (Factory default value is 0.2 of the range)	
sp1	Hold down [+] or [-] for at least 1s. After 1 second: The setting value can be changed: At the press of a button, the value increases; Hold the button down and the value will keep changing.	
	Switch 1 Reset value (factory default is SP1-0.5)	
rp1	Hold down [+] or [-] for at least 1s. After 1 second: The setting value can be changed: At the press of a button, the value increases; Hold the button down and the value will keep changing.	
	Switch 2 alarm value (factory default value is 0.8 of the range)	One switch None of this.
sp2	Hold down [+] or [-] for at least 1s. After 1 second: The setting value can be changed: At the press of a button, the value increases; Hold the button down and the value will keep	
	Switch 2 Reset value (Factory default value is SP2-0.5)	factory data reset Range reference value
rp2	Hold down [+] or [-] for at least 1s. After 1 second: The setting value can be changed: At the press of a button, the value increases; Hold the button down and the value will keep	
	Lower range limit (factory default is lower range limit)	factory data reset Range reference value
asp	Hold down [+] or [-] for at least 1s. After 1 second: The setting value can be changed: At the press of a button, the value increases; Hold the button down and the value will keep changing.	
	Range upper limit (Factory default is range upper limit)	factory data reset Range reference value
aep	Hold down [+] or [-] for at least 1s. After 1 second: The setting value can be changed: At the press of a button, the value increases; Hold the button down and the value will keep changing.	
	Expand functionality/Open the Level 2 menu	
EF	Press the [M] key to enter the Extended 2 level menu Press [+] to exit.	

Level 2 menu		
res	factory data reset	
	Hold down [+] to restore factory Settings	
ou1	Switch 1 signal: (Factory default is HNO) Hysteresis function: HNO (normally open) /HNC (normally closed) Window function: FNO (normally open) /FNC (normally closed) IO-Link: (Only S2/SA signal output)	
	Hold down [+] or [-] for at least 1s. After 1 second: The setting value can be changed:At the press of a button, the value increases; Hold the button down and the value will keep changing.	
ou2	Switch 2 signal: (Factory default HNC) Hysteresis function: HNO (normally open) /HNC (normally closed) Window function: FNO (normally open) /FNC (normally closed)	One switch None of this.
	Hold down [+] or [-] for at least 1s. After 1 second: The setting value can be changed:At the press of a button, the value increases; Hold the button down and the value will keep changing.	
ds1	The opening delay of OUT1. (The factory default is 0s)	
	Hold down [+] or [-] for at least 1s. After 1 second: The setting value can be changed:At the press of a button, the value increases; Hold the button down and the value will keep changing.	
dr1	OUT1 shutdown delay. (The factory default is 0s)	
	Hold + or [-] for at least 1s. After 1 second: The setting value can be changed:At the press of a button, the value increases; Hold the button down and the value will keep changing.	
ds2	OUT2's opening delay. (The factory default is 0s)	One switch None of this.
	Hold down [+] or [-] for at least 1s. After 1 second: The setting value can be changed:At the press of a button, the value increases; Hold the button down and the value will keep changing.	
dr2	OUT2 shutdown delay. (The factory default is 0s)	
	Hold down [+] or [-] for at least 1s. After 1 second: The setting value can be changed:At the press of a button, the value increases; Hold the button down and the value will keep changing.	

	System standard unit of measurement (display)
uni	Hold down [+] or [-] for at least 1s. After 1 second: The setting value can be changed: At the press of a button, the value increases; Hold the button down and the value will keep changing.
	Modify the number of decimal points
-dp-	Hold down [+] or [-] for at least 1s. After 1 second: The setting value can be changed: At the press of a button, the value increases; Hold the button down and the value will keep changing.
	PNP/NPN switch (Factory default is PNP)
p-n	Hold down [+] or [-] for at least 1s. After 1 second: The setting value can be changed: At the press of a button, the value increases; Hold the button down and the value will keep changing.
	System measurement history minimum.
LO	Hold down [+] or [-] for at least 1s. After 1 second: The setting value can be changed: At the press of a button, the value increases; Hold the button down and the value will keep changing.
	The maximum value of system measurement history
HO	Hold down [+] or [-] for at least 1s. After 1 second: The setting value can be changed: At the press of a button, the value increases; Hold the button down and the value will keep changing.
	Switch point damping/process data flow (IO-Link communication) and display. (Factory default: 0.06)
dap	Hold down [+] or [-] for at least 1s. After 1 second: The setting value can be changed: At the press of a button, the value increases; Hold the button down and the value will keep changing.
	Update rate and direction of the display (d1 by default)
dis	Hold down [+] or [-] for at least 1s. After 1 second: The setting value can be changed: At the press of a button, the value increases; If you hold the button down, the value will keep changing. [d1] : The measured value is updated every 10ms [d2] : The measurement is updated every 100ms [d3] : Update measurement every 600ms

zeao	Zero excision value (full scale %) (factory default is 0.5)		
	Hold down [+] or [-] for at least 1s. After 1 second: The setting value can be changed: At the press of a button, the value increases; Hold the button down and the value will keep changing.		
daa	Display refresh time: analog 0.1s (factory default is 0.01)		
	Hold down [+] or [-] for at least 1s. After 1 second: The setting value can be changed: At the press of a button, the value increases; Hold the button down and the value will keep changing.		
iout	Output analog switch: Current type: 4-20: (4-20mA) 0-20: (0-20mA) 20-4: (20-4mA) 20-0: (20-0mA) 5V voltage type: 1-5F: (1-5V) 0-5F: (0-5V) 10V voltage type: 210F: (2-10V) 110F: (1-10V) 010F: (0-10V)		No analog quantity None of this.
	Hold down [+] or [-] for at least 1s. After 1 second: The setting value can be changed:At the press of a button, the value increases; Hold the button down and the value will keep changing.		
EF	Expand functionality/Open the Level 2 menu		
	Press the [M] key to enter the Extended 2 level menu Press [+] to exit.		

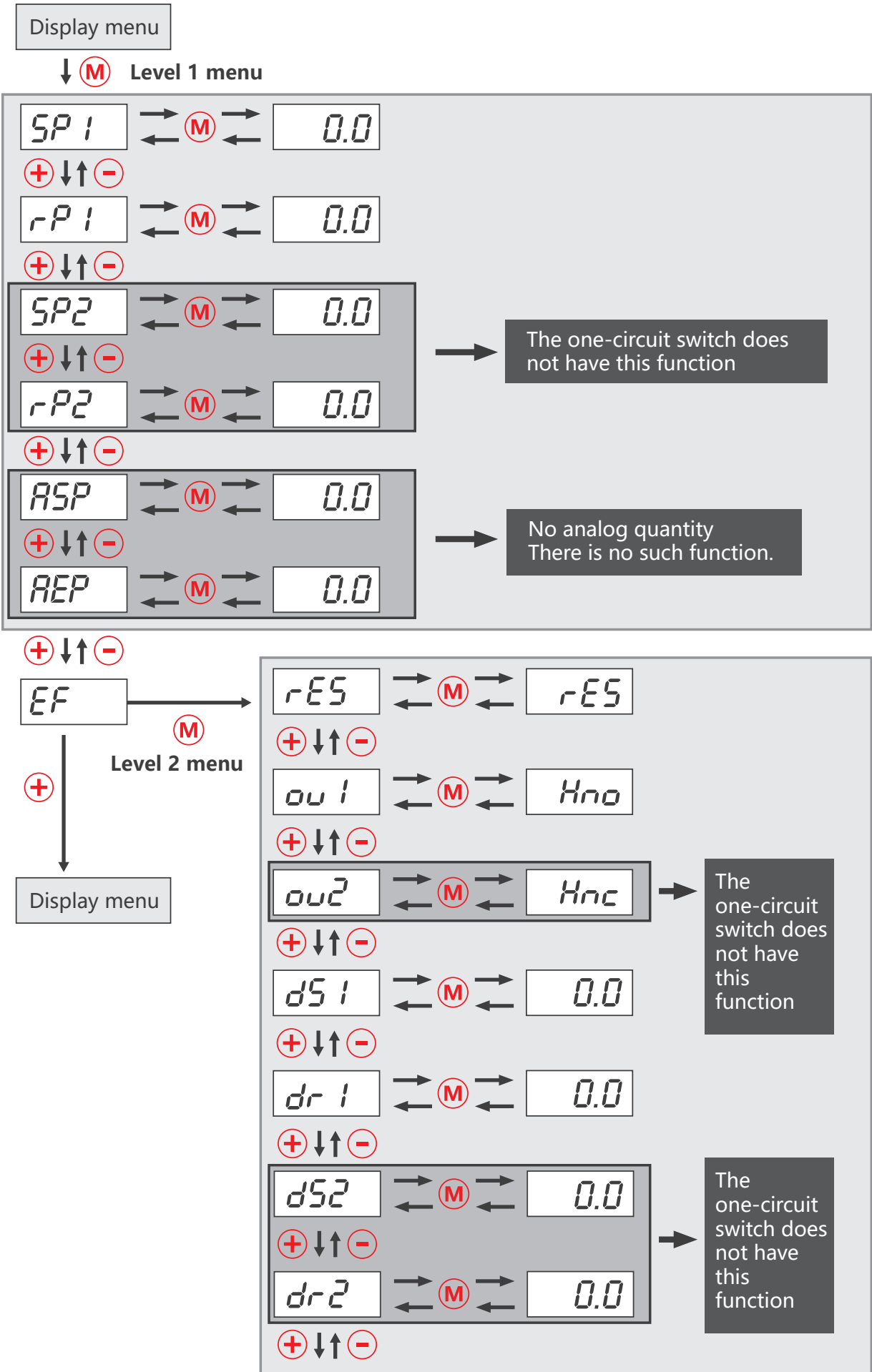

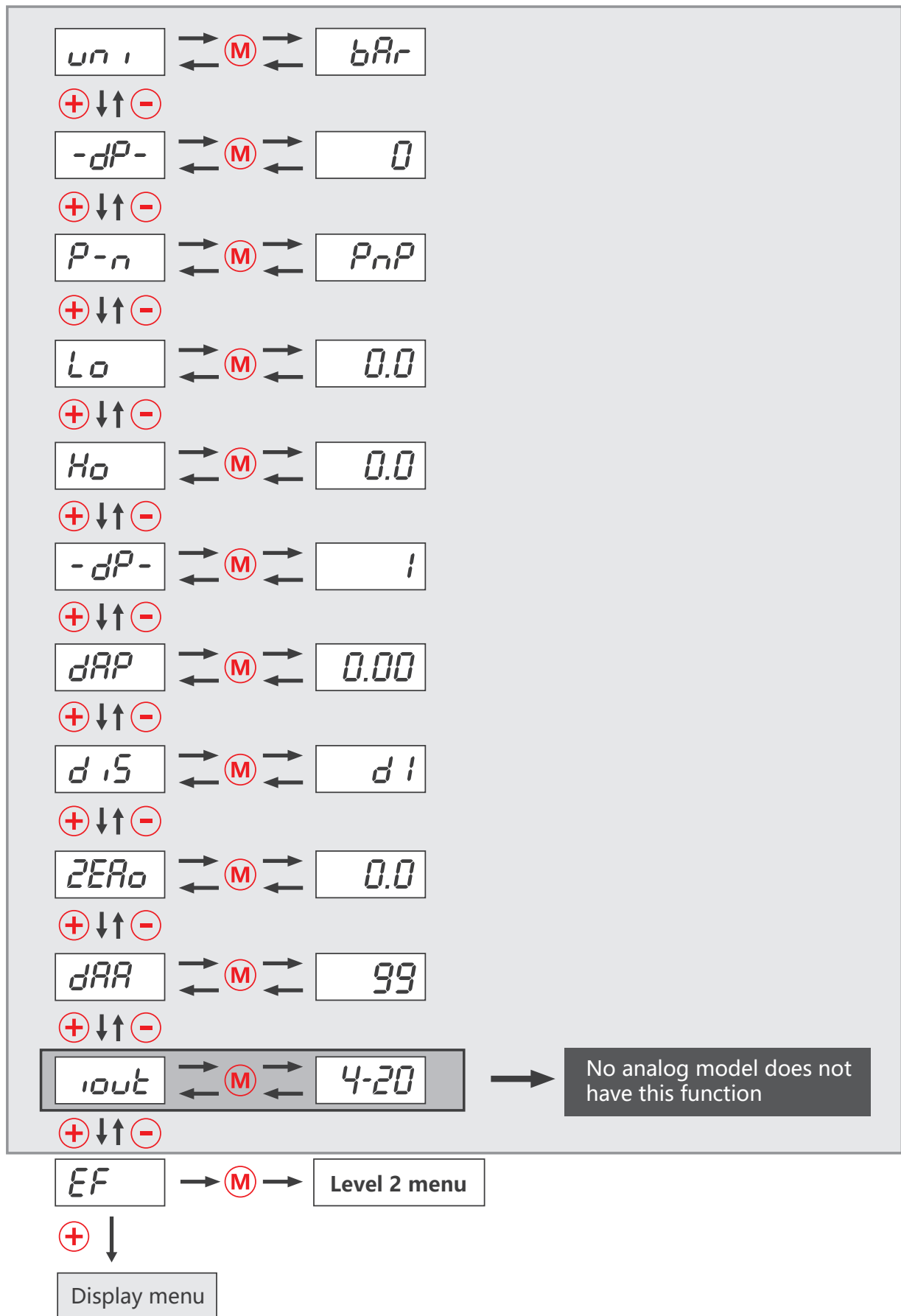

Electrical connection (RS485 communication)

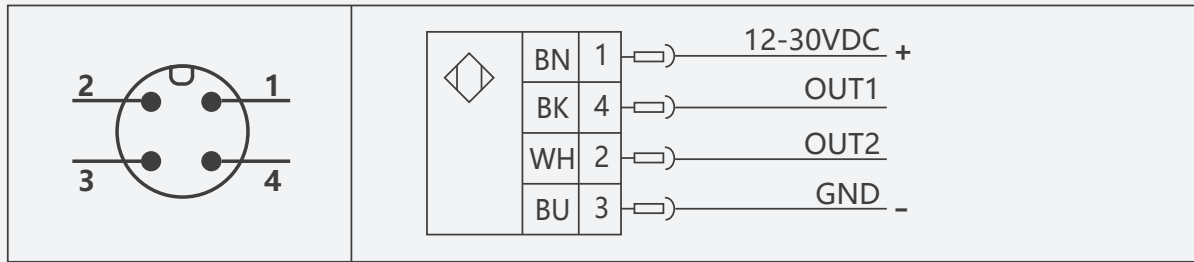

RS485		
color	stitch	Instructions
BN	1	power supply (+)
BU	3	power supply (-)
BK	4 (OUT1)	RS485(B)
WH	2 (OUT2)	RS485(A)

Debugging/operation

Level 1 menu	
id	Address (system default is 1)
	Press and hold [+] or [-] for at least 1s. After 1 second: The setting value can be changed: At the press of a button, the value increases; Press and hold the button while the value continues to change.
baud	Baud rate setting (System default is 2)
	Press and hold [+] or [-] for at least 1s. After 1 second: The setting value can be changed: At the press of a button, the value increases; Press and hold the button while the value continues to change.
EF	Expand functionality/Open the Level 2 menu
	Press the [M] key to enter the Extended level 2 menu Press the [+] key to exit

Level 2 menu	
res	factory data reset
	Press and hold [+] to restore factory Settings
uni	Standard unit of measurement for system pressure (display) : [bar]/[MPa]/[psi]
	Hold [+] or [-] for at least 1s. After 1 second: The setting value can be changed: At the press of a button, the value increases; Press and hold the button while the value continues to change.
L0	Historical minimum system pressure.
	Hold [+] or [-] for at least 1s. After 1 second: The setting value can be changed: At the press of a button, the value increases; Press and hold the button while the value continues to change.
H0	Historical maximum system pressure
	Hold [+] or [-] for at least 1s. After 1 second: The setting value can be changed: At the press of a button, the value increases; Press and hold the button while the value continues to change.
dap	Switch point damping/process data flow (IO-Link communication) and display.
	Hold [+] or [-] for at least 1s. After 1 second: The setting value can be changed: At the press of a button, the value increases; Press and hold the button while the value continues to change.

	Update rate and direction of the display. (Factory default is d1)
dis	<p>Hold [+] or [-] for at least 1s. After 1 second: The setting value can be changed:</p> <p>At the press of a button, the value increases; Press and hold the button while the value continues to change.</p> <p>[d1] : The measurement value is updated every 10ms [d2] : The measurement is updated every 100ms [d3] : Update the measurement every 600ms</p>
	Zero excision value (full scale %) (factory default is 0.5)
zeao	<p>Hold [+] or [-] for at least 1s. After 1 second: The setting value can be changed:</p> <p>At the press of a button, the value increases; Press and hold the button while the value continues to change.</p>
	Expand functionality/Open the Level 2 menu
EF	<p>Press the [M] key to enter the Extended Level 2 menu</p> <p>Press the [+] key to exit.</p>

Display menu

↓ (M) Level 1 menu

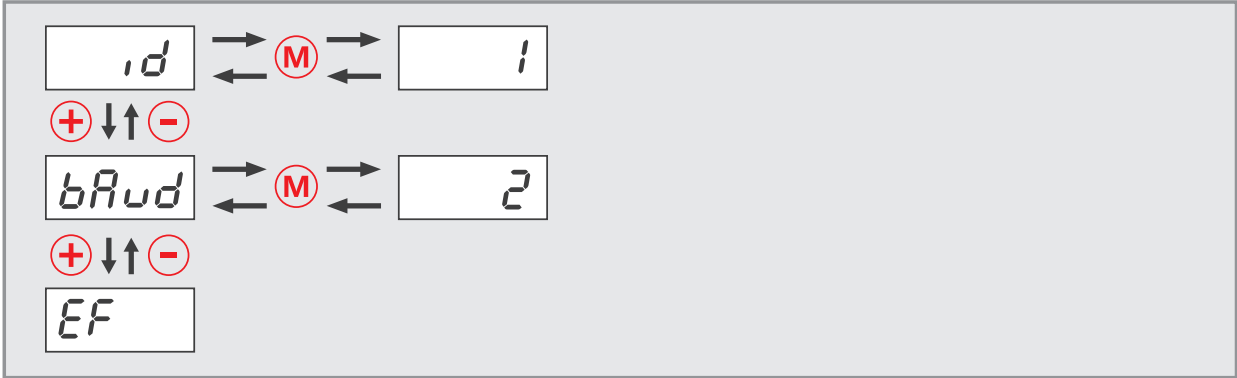

(+) (M) Level 2 menu
Display menu

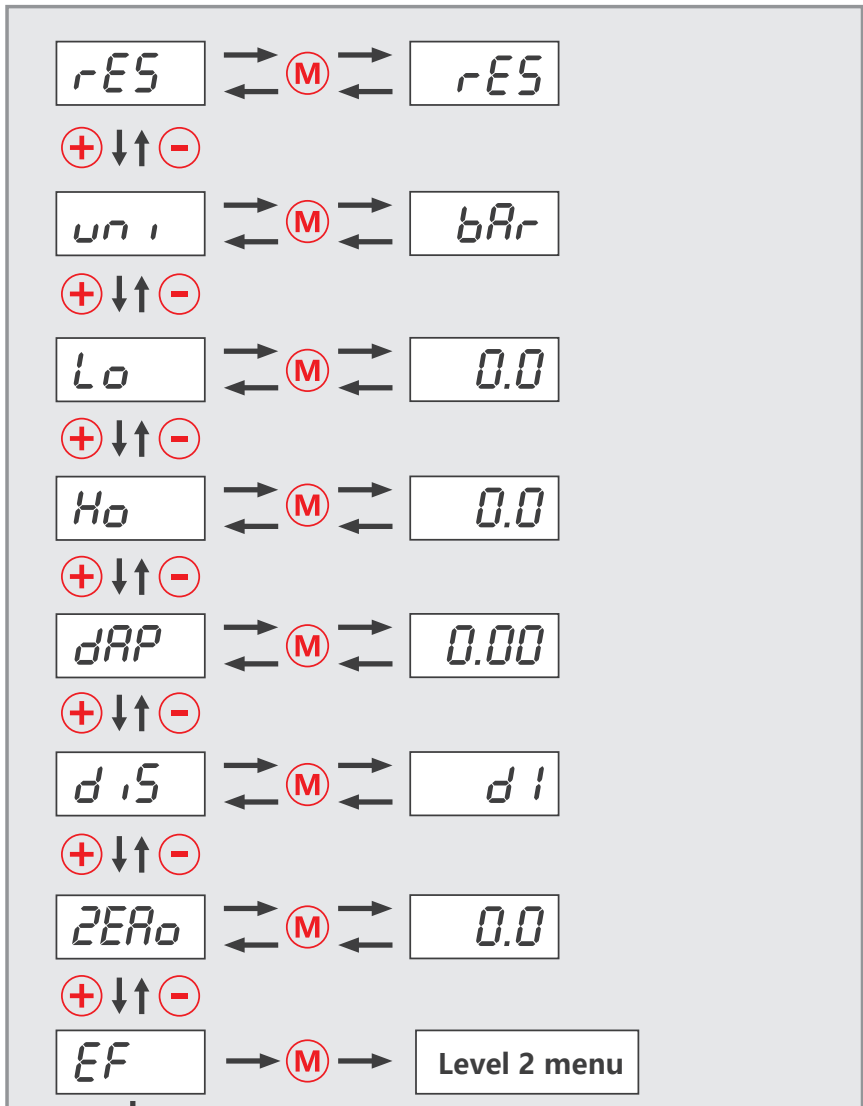

(+) Display menu

Maintenance/cleaning

Sensors (switches) do not require maintenance.



warning

Periodically check whether the switch is working properly.

If the switch does not work properly, stop the operation immediately.



caution

Use of improper cleaning agent may damage the switch.

The following cleaning agents can be used to clean polycarbonate: mild soap or detergent Isopropyl alcohol

Immediately after cleaning, rinse with water. Do not leave cleaner on the surface of the product. Do not clean products in high heat or direct sunlight.

The following cleaning agents are known to affect the integrity of polycarbonate components and should not be used: ZEP Fast 505, Pinesol, Formula 409

Halogenated solvents (benzene, gasoline, acetone or carbon tetrachloride)

Strong alkalinity

Methyl ethyl ketone

Abrasive substance

disassemble



danger

Only remove the switch in case of power failure (electrical, hydraulic/pneumatic).

Switch disconnection from pressure and power supply must be performed by trained or directed personnel in accordance with the most advanced standards.



warning

Be aware that the surface of the shell may become very hot if the operating temperature is higher!

**PS500-RS485
communication protocol (MODBUS-RTU)**

1. RTU Data format explanation

1.1 communication mode

This instrument uses MODBUS RTU format. The protocol is used for master-slave query mode data communication.

1.2 data format

In RTU mode, the format of each byte (10 bits) is as follows: The encoding system uses 8-bit binary. Each byte consists of 1 start bit, 8 data bits (transmitting the least significant bit first), and 1 stop bit. The baud rate options are: 2400, 4800, 9600, 19200, and 115200.

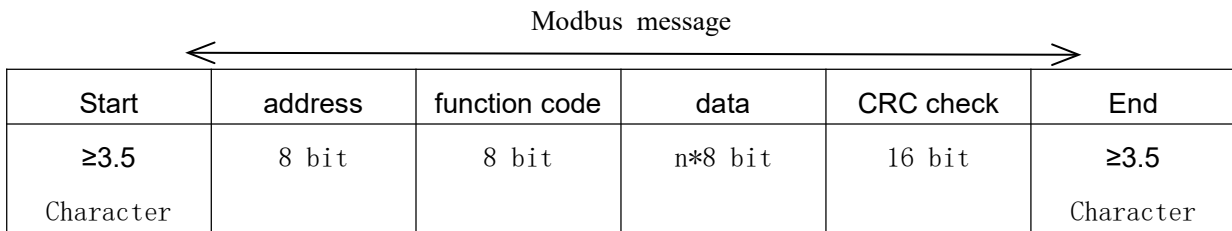

Note:

- 1) In RTU mode, idle intervals of at least 3.5 character times separate message frames.
- 2) (2) The entire message frame must be sent as a continuous stream of characters.
- 3) (3) The idle interval between two characters should not exceed 1.5 character times.

1.3 address

The agreement specifies that the instrument's address is '0-255', where the '0' address is used for broadcasting. This protocol does not support broadcasting, and the remaining addresses are reserved.

2 . Configuration instructions

500 series pressure sensor, no parity check, 8 data bits, 1 stop bit

500 series pressure sensor		
parity check	/	Fixed and unchangeable
bit	8	Fixed and unchangeable
stop bit	1	Fixed and unchangeable

display code	Parameter definition	Scope	explain
id	Sensor address code (default 1)	1-250	Sensor address cannot conflict with other sensor addresses.
baud	Sensor baud rate (default 2)	0-5	0: Baud rate is 2400 bps 1: Baud rate is 4800 bps 2: Baud rate is 9600 bps 3: Baud rate is 19200 bps 4: Baud rate is 115200 bps

3. instruction explanation

03H (Read the instructions)

send data: 01 03 00 00 00 03 05 CB (16 Octal)

Instruction	01	03	00	00	00	03	05	CB
explain	sensor address	Read the instructions	The high-order starting address of the register	The lower part of the starting address of the register	Read high-order quantity	Read the lower digit of the quantity	CRCL	CRCH

Explain: Send a read command to the 01 sensor, start reading from register 0000, and read 0003 registers.

Return data: 01 03 06 00 00 01 23 00 01 10 83 (16 Octal)

Instr uction	01	03	06	00	00	01	23	00	01	10	83
explain	sensor address	Read the instructions	Return six data points.	Register 1 high bit	Register 1 low bit	Register 2 high bit	Register 2 low bit	Register 3 high bit	Register 3 low bit	CRCL	CRCH



Explanation: 01 sensor responds to the read command, returning 6 data points
 00 00: 0000H, which is decimal 0, indicating that the pressure sign is 0, i.e., it is positive pressure;
 01 23: 0123H, which is decimal 291, indicating that the pressure value is 291;
 00 01: 0001H, which is decimal 1, indicating that the pressure has one decimal place;
 The pressure value is 29.1.

4. Address (register) and its meaning

Decimal, hexadecimal, and Modbus registers represent the same parameter but in different formats. Different upper-level machine software may use different formats; if one format is not recognized, you can try the other two.

decimal address	Hexadecimal address	MODBUS Register	Parameter definition	Explanation
0	0	40001	Positive or negative pressure	Positive and negative (0 is positive, 1 is negative)
1	1	40002	Pressure value	Read the value (units displayed on the same screen)
2	2	40003	Decimal places of the pressure value	1 is one decimal point (the number is displayed on the same screen)

Katu Electronic (Kunshan) Co.,Ltd.

-  telephone: 400-150-8815
-  Website: www.katusensor.com
-  Factory: Building 27B, Jingdong Intelligent Industrial Park,
No.9 Jinjie Road, Huaqiao Economic Development Zone,
Kunshan City, Suzhou