

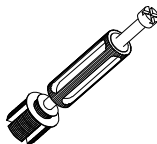

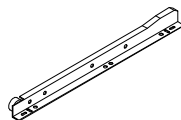

<p>A</p>  <p>20PCS</p>	<p>G</p> <p>300MM</p>  <p>1PCS</p>	<p>M</p> <p>φ 60</p>  <p>2PCS</p>
<p>B</p>  <p>20PCS</p>	<p>H</p> <p>3.5*14</p>  <p>8PCS</p>	<p>N</p> <p>φ 80</p>  <p>1PCS</p>
<p>C</p> <p>8*40</p>  <p>14PCS</p>	<p>I</p> <p>3.5*25</p>  <p>4PCS</p>	<p>O</p> <p>4*50</p>  <p>4PCS</p>
<p>D</p> <p>300MM</p>  <p>1PCS</p>	<p>J</p> <p>3.5*35</p>  <p>4PCS</p>	<p>P</p>  <p>4PCS</p>
<p>E</p> <p>300MM</p>  <p>1PCS</p>	<p>K</p> <p>128MM</p>  <p>1PCS</p>	<p>Q</p>  <p>2PCS</p>
<p>F</p> <p>300MM</p>  <p>1PCS</p>	<p>L</p> <p>4*20</p>  <p>2PCS</p>	<p>R</p>  <p>2PCS</p>

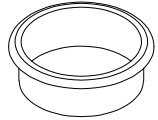

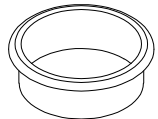
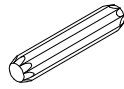
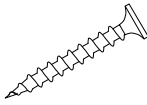
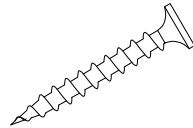
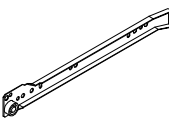
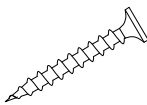
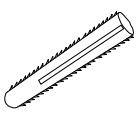
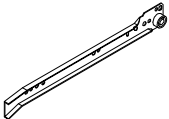
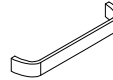
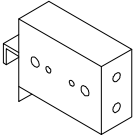
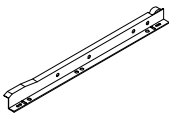

Hardware installation demonstration

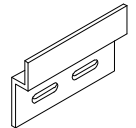
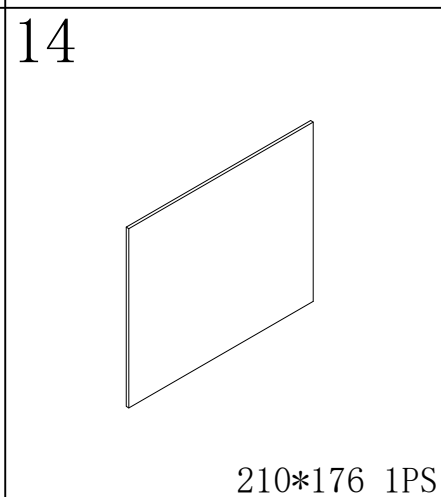
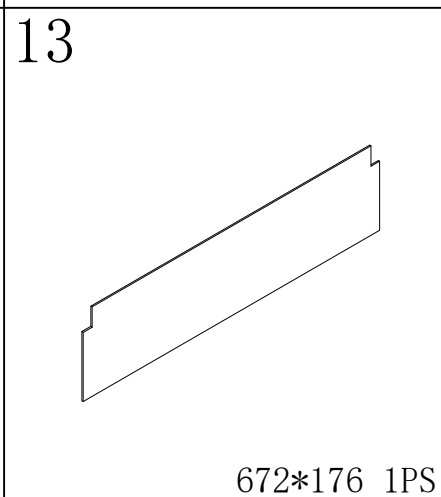
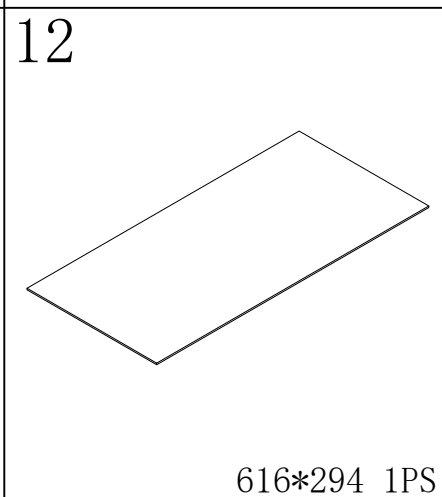
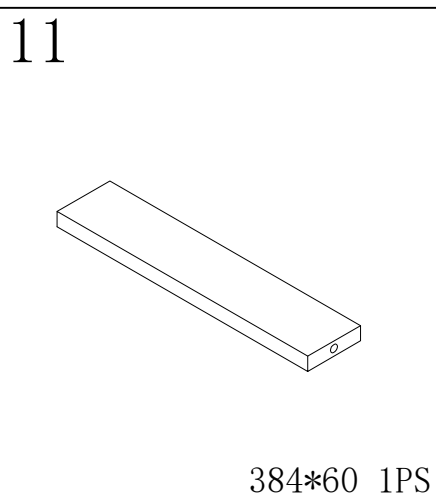
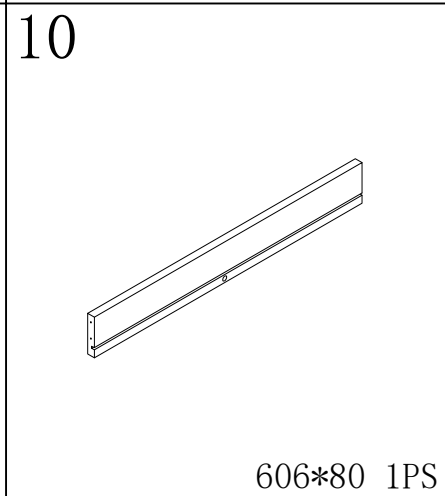
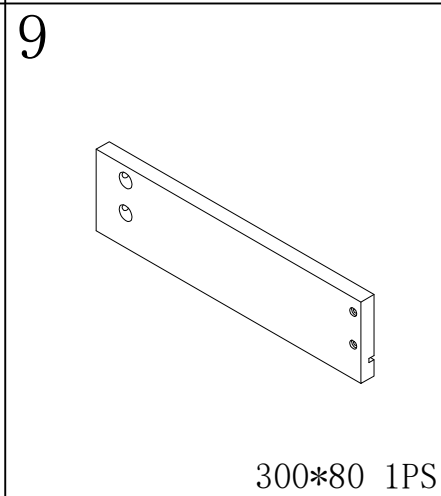
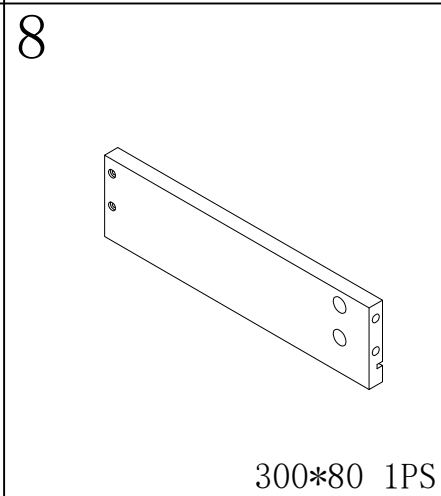
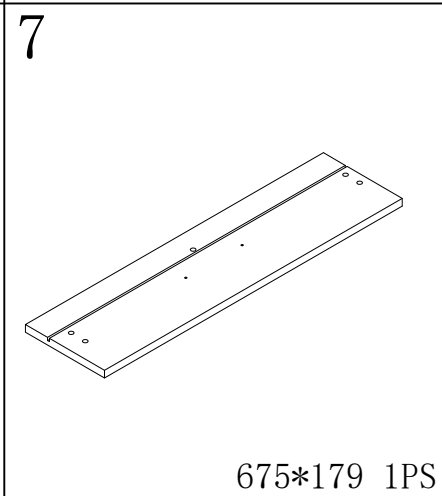
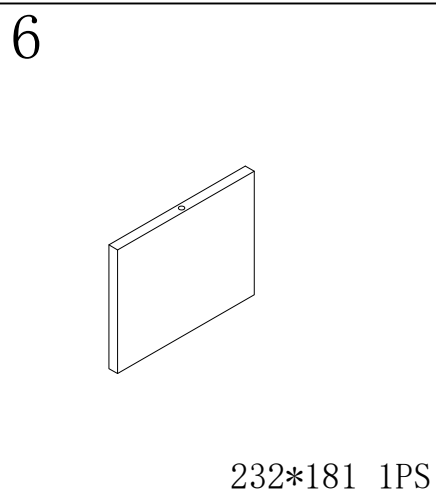
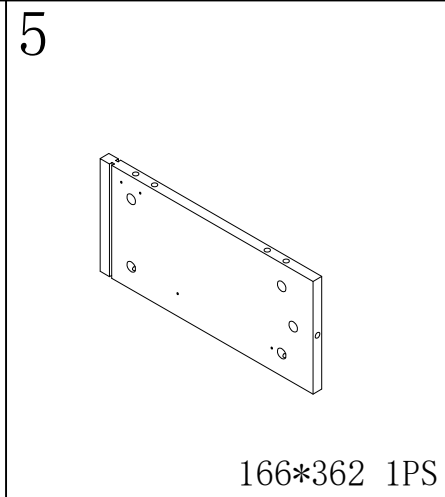
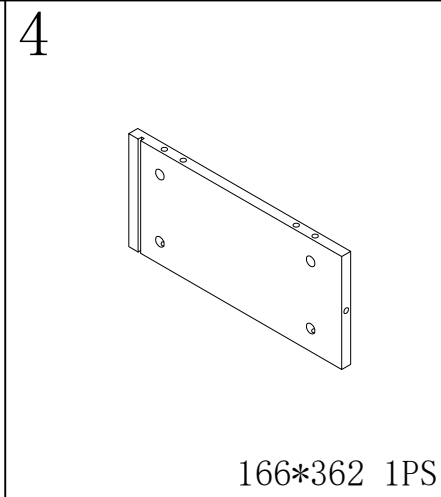
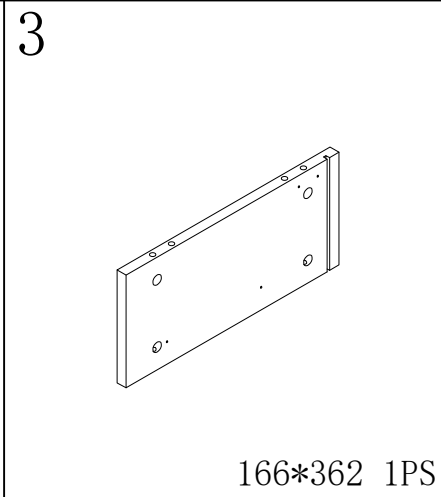
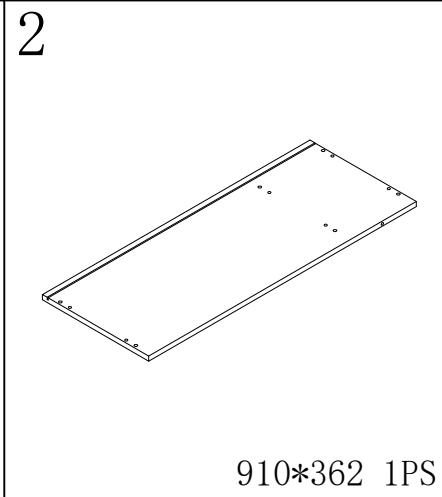
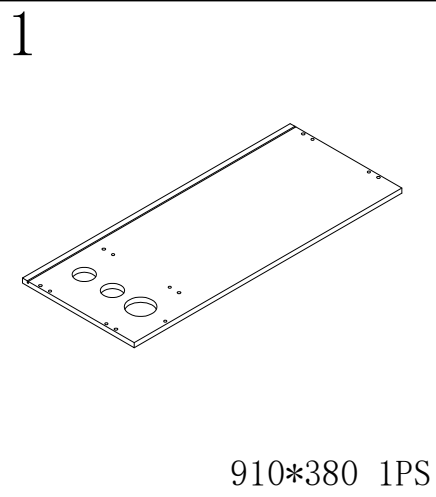
NOTE: Please make sure "A" hardware tightened and can't be pulled out!

I

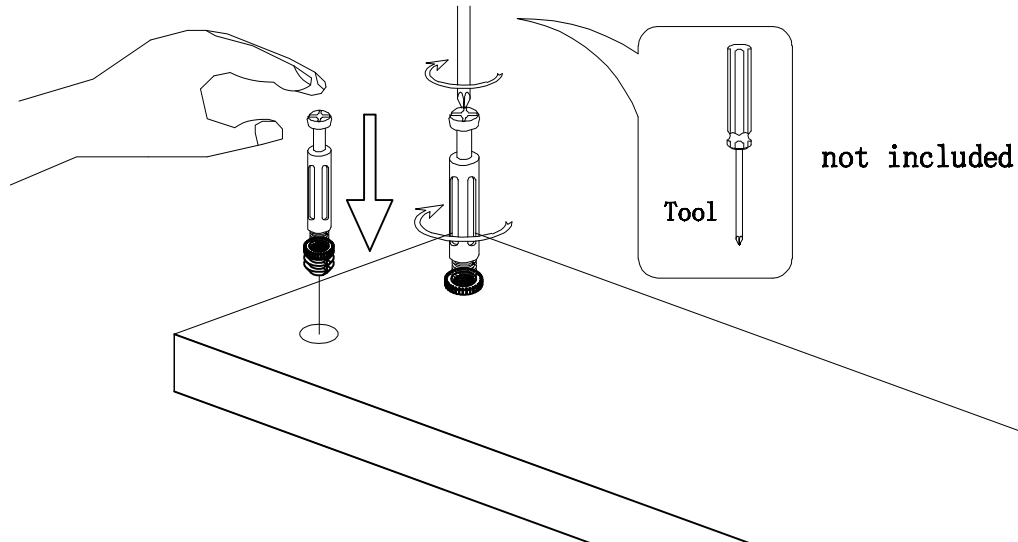

II

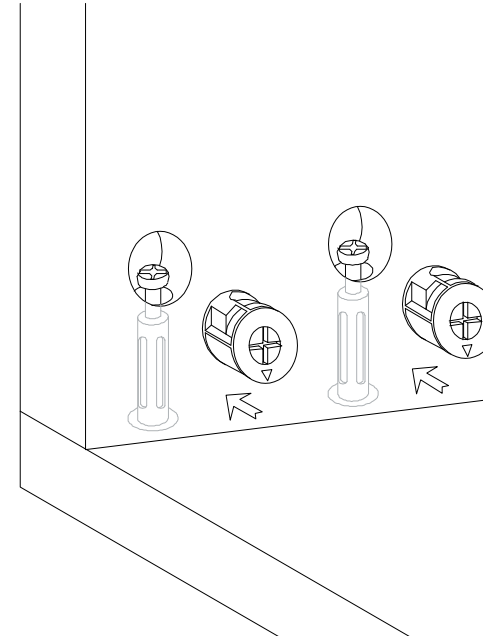

III

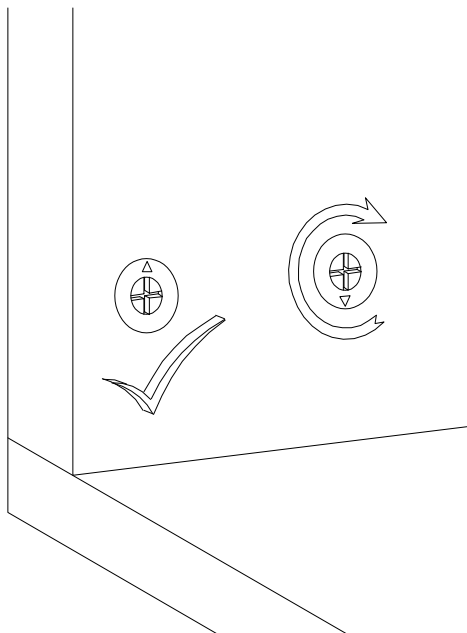





IV

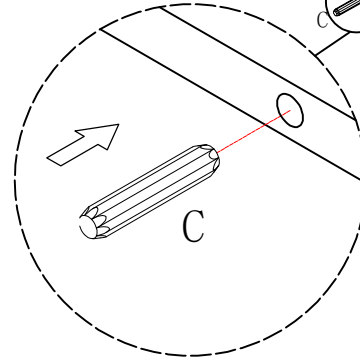
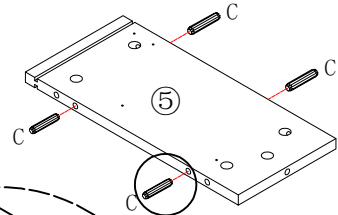
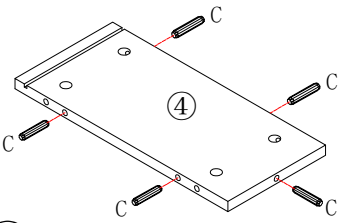
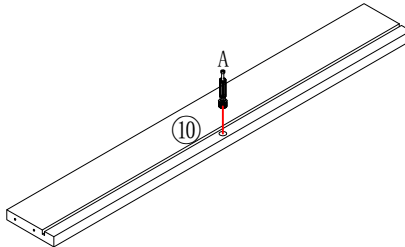
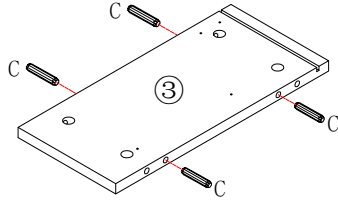
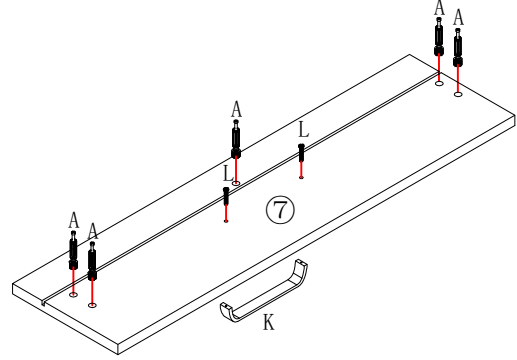
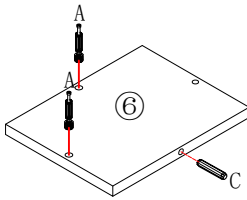
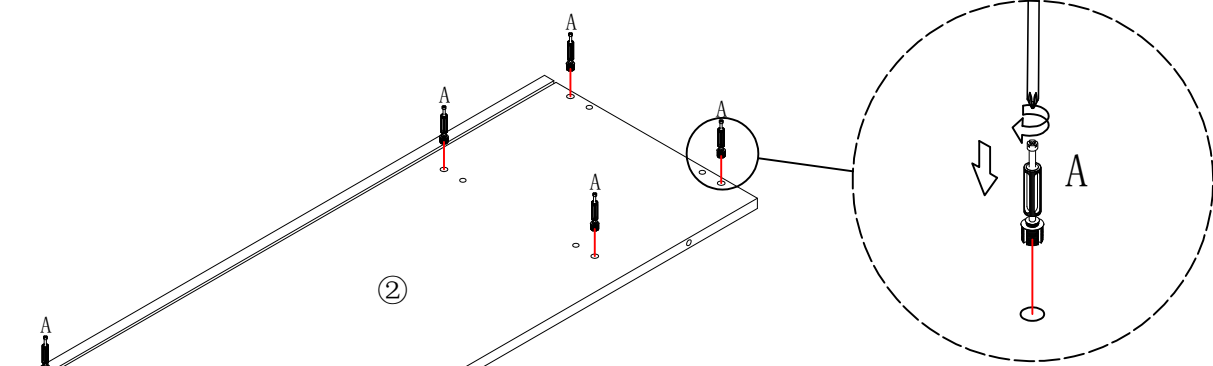
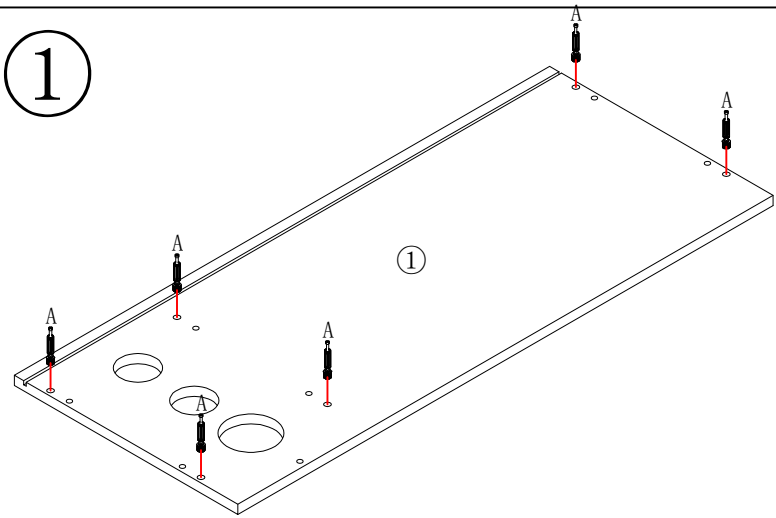

Scan QR code for assembly video

1



	A*20
	C*14
	K*1
	L*2



put A on board ①②⑥⑦⑩

put C on board ③④⑤⑥⑦⑩

2

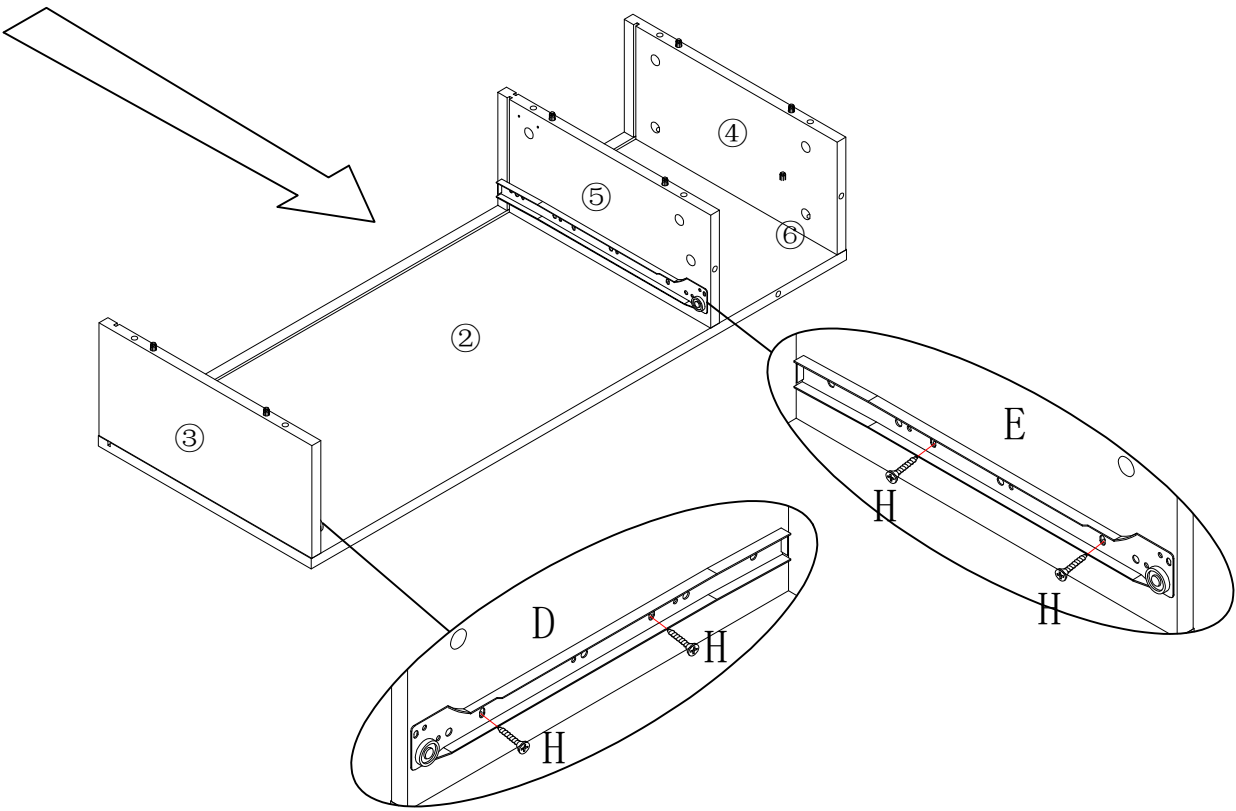
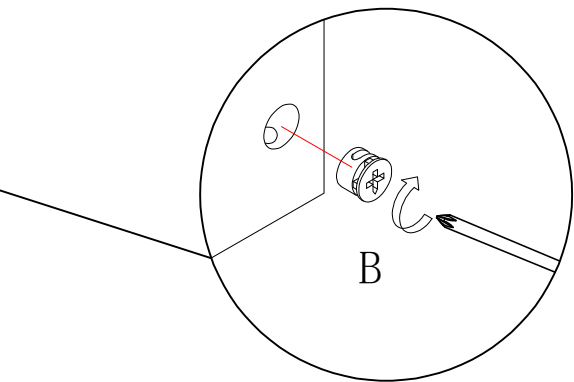
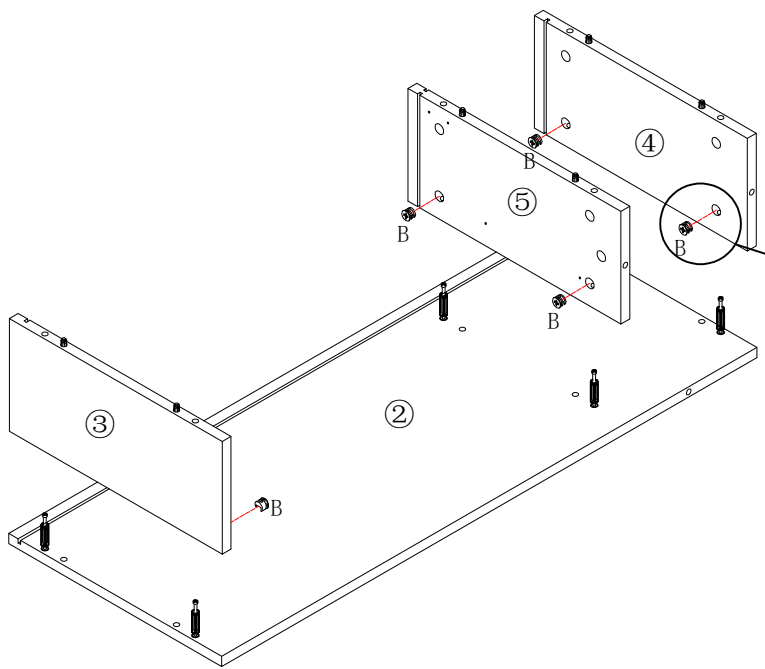
Make sure the arrow on the screw align to the hole on the side.

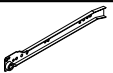

	B*6
	D*1
	E*1
	H*4

put B on board ③④⑤

3

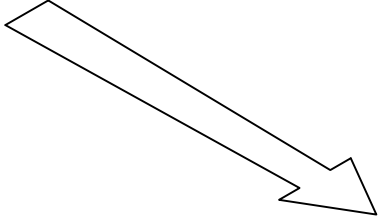
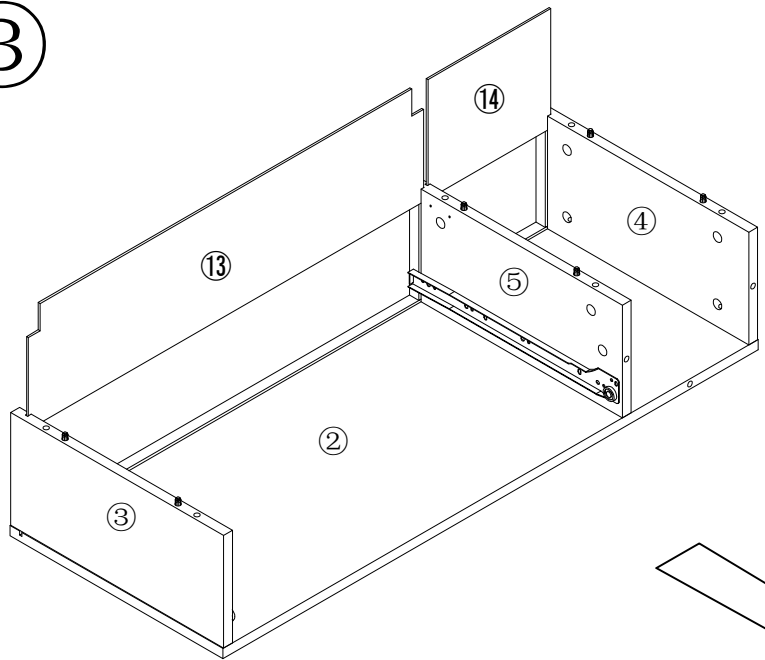

Make sure the arrow on the screw align to the hole on the side.

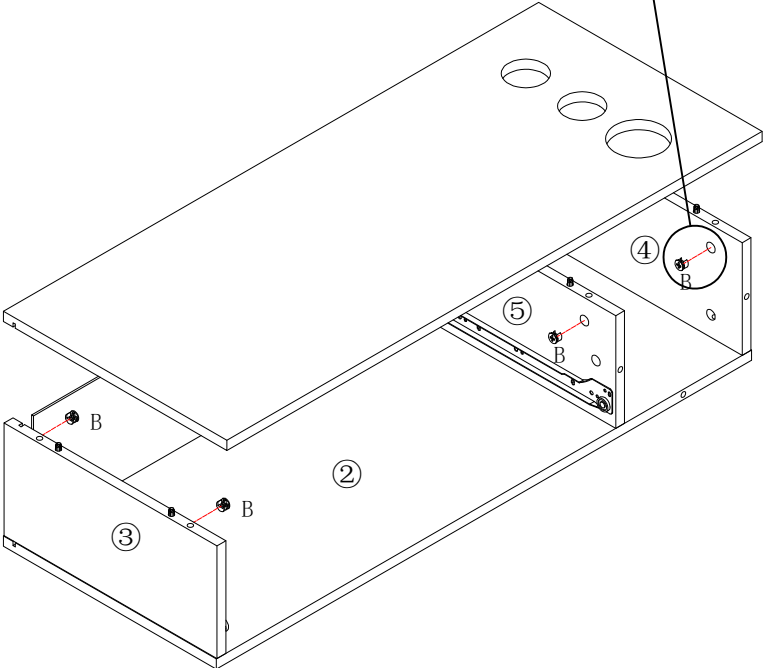
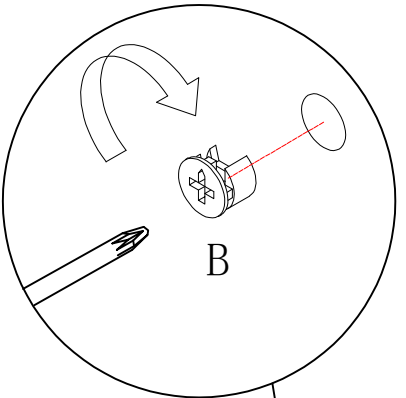

B*6 put B on board 3 4 5

4

Make sure the arrow on the screw align to the hole on the side.

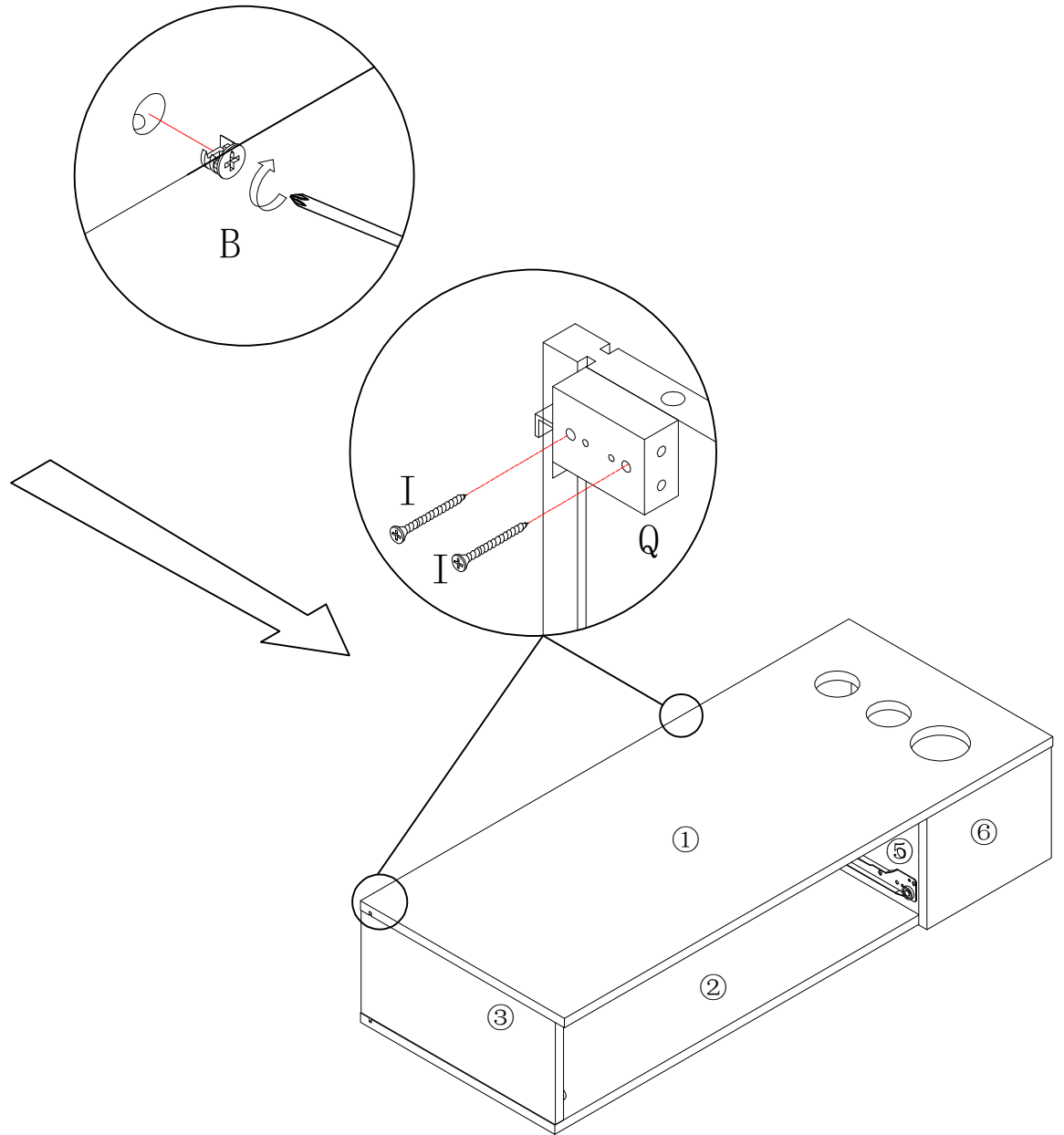
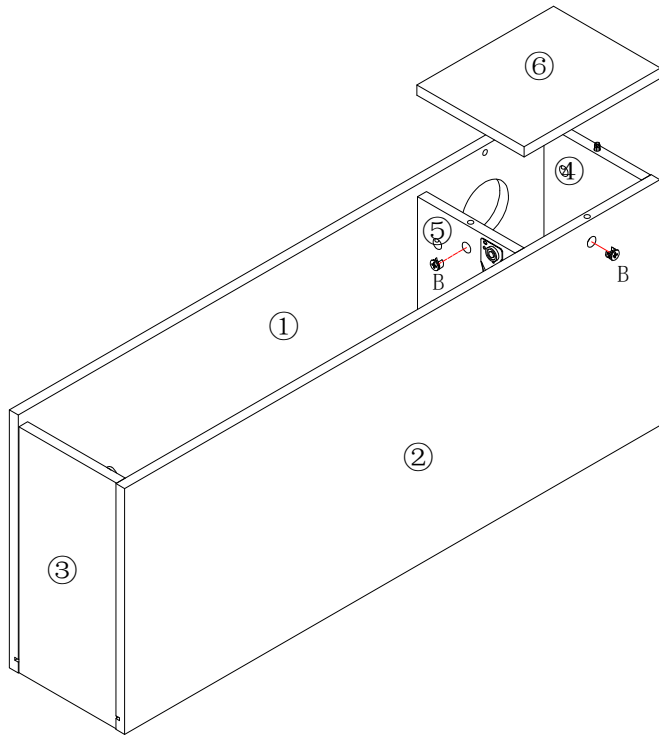

B*2

put B on board ④⑤



I*4





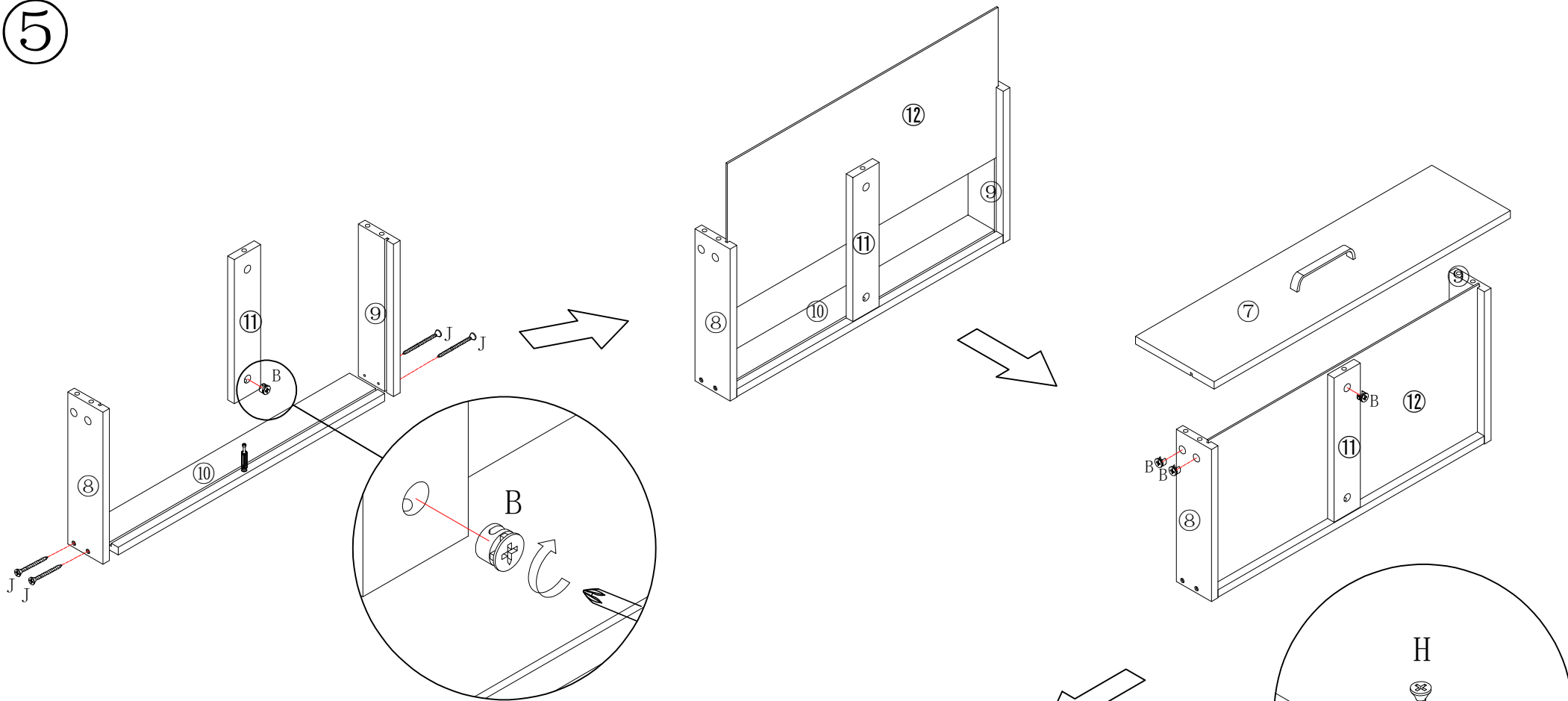

Q*2

5

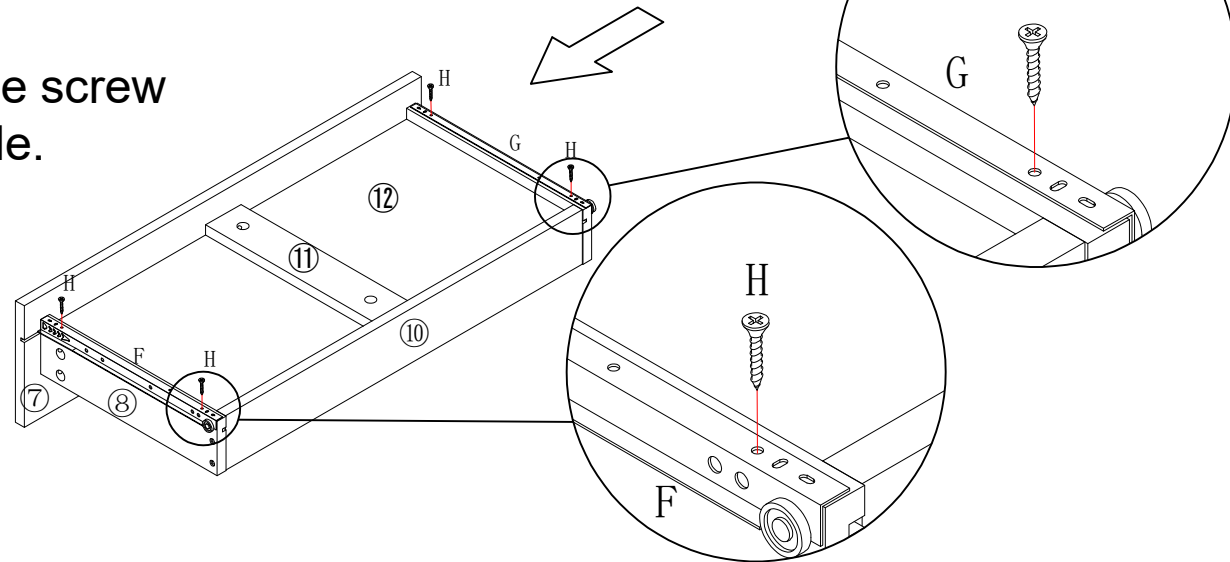

Make sure the arrow on the screw align to the hole on the side.

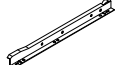
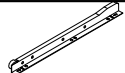

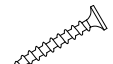
	B*6
	F*1
	G*1
	H*4
	J*4

put B on board 9 10

6

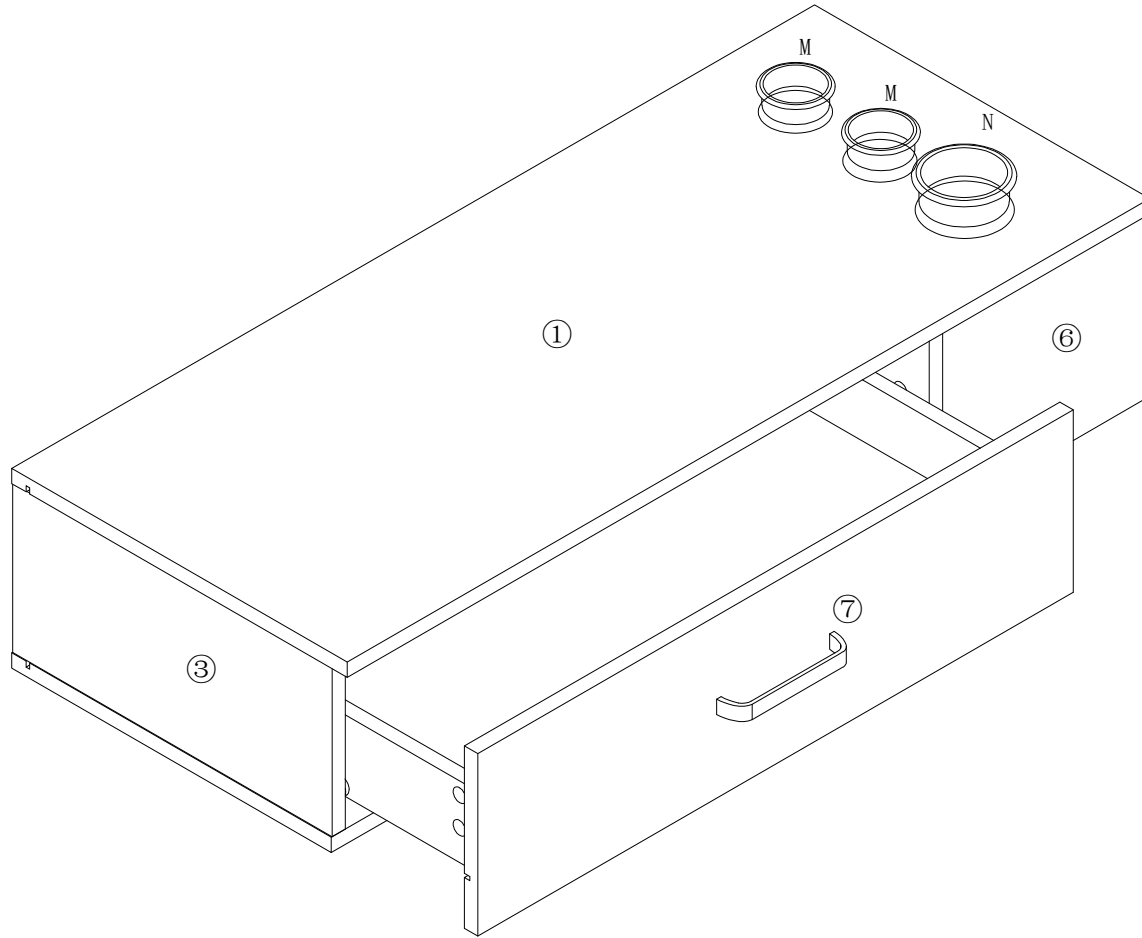



M*2

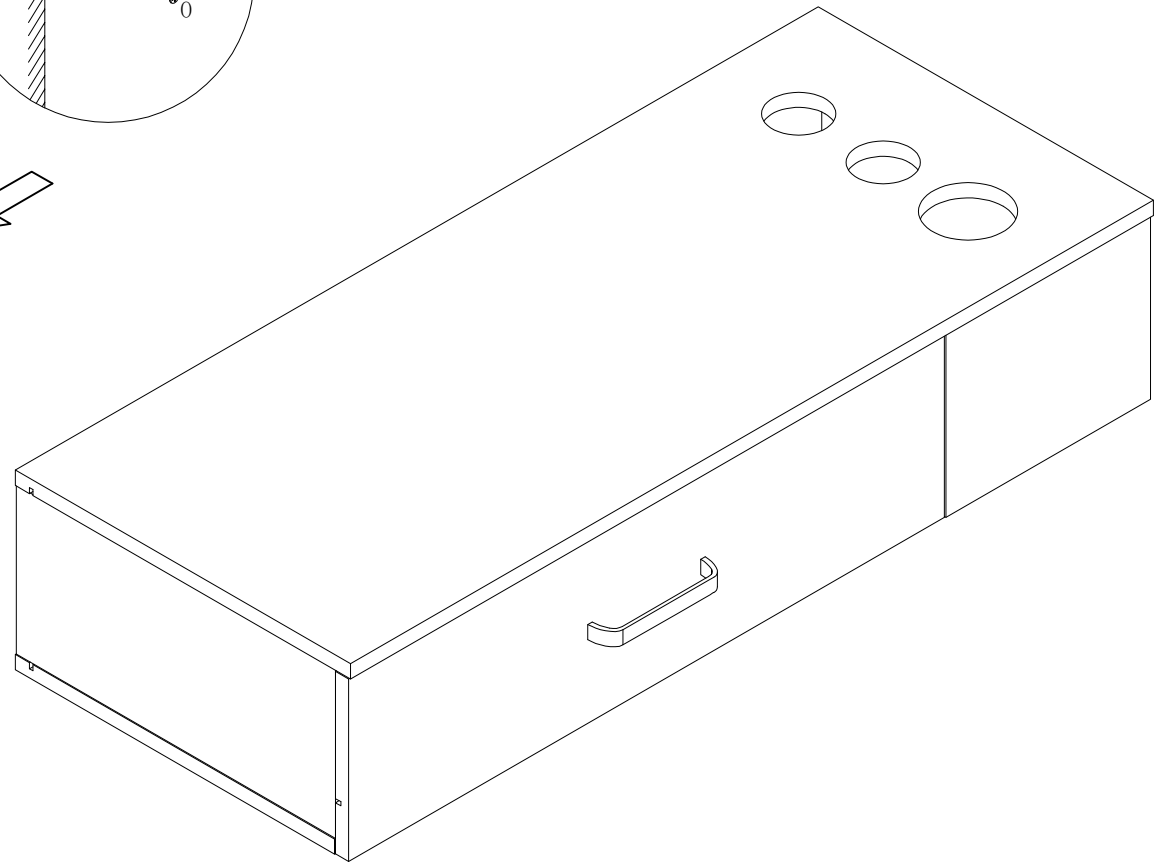
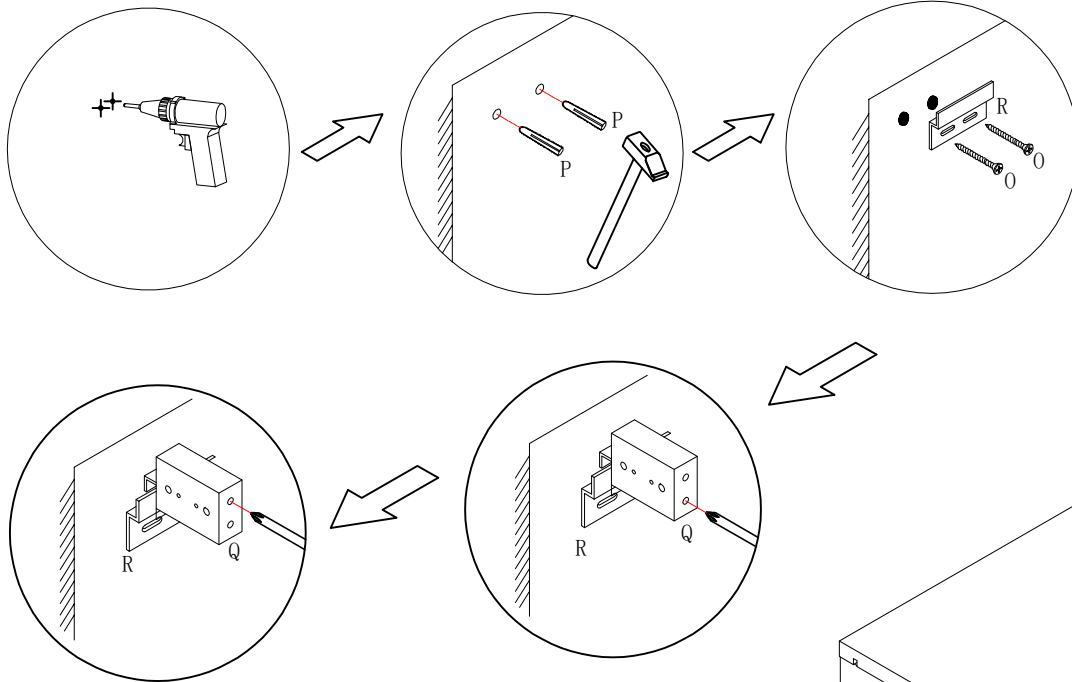
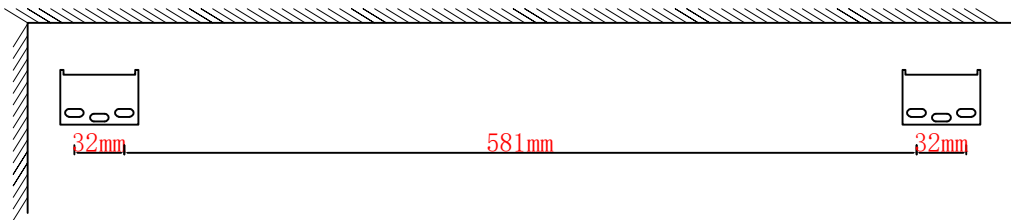

N*1

7

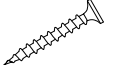

	O*4
	P*4
	R*2

8

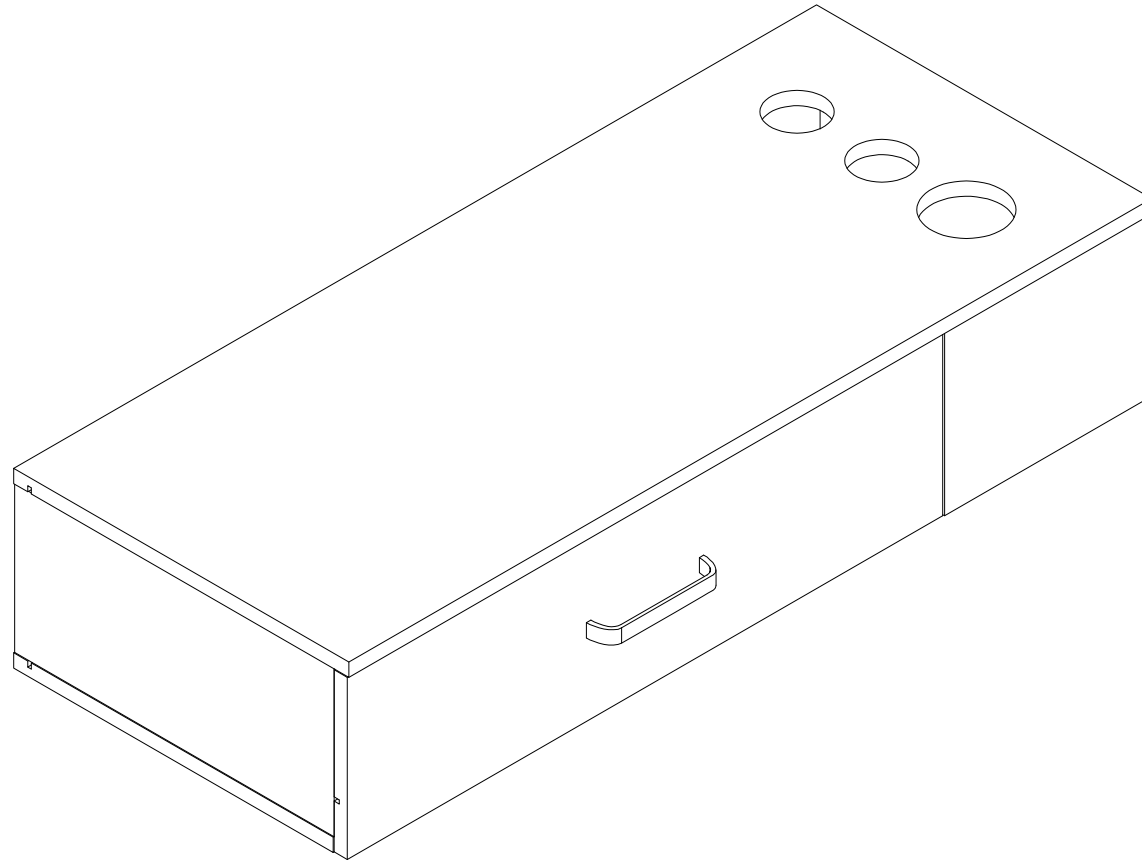

---END---