

# Technical Data Sheet (TDS)

## Hyper Speed TPU

ERYONE-Hyper Speed TPU filament is an efficient printing material, with a printing speed approximately three times that of conventional TPU, significantly enhancing printing efficiency. This material is not only soft but also possesses high toughness and excellent impact resistance, making it ideal for protective cases for mobile phones and other electronic devices. It is necessary to appropriately increase the retraction distance to reduce stringing. The hardness is 95A.

### Part I: Suggests Printing Parameters

Parameter	Set up
Nozzle temperature	200°C-220 °C
Bed temperature	0-60°C
Bed material	glass, PEI, spring steel plate
Bottom printing temperature	200-220 °C
Sealed printing	Open printing / closed printing
Printing speed	≤300mm/s
Drying conditions	55-60°C, 6-8h

### Part II: Physical Properties of Materials

Property	Testing Method	Unit	Typical Value
Density(g/cm <sup>3</sup> at 21.5 ° C)	ASTM D792 (ISO 1183, GB/T 1033)	g/cm <sup>3</sup>	1.22
Melt Index(g/10 min)	220 ° C, 10kg 240 ° C, 2.16 kg	g/10min	36

## Part III: Mechanical Properties of Printed Samples

Property	Test conditions	Test standards	unit	Typical Value
Elastic modulus X-Y	50mm/min	GB/T 1040.1-2006	MPa	27
Tensile strength X-Z	50mm/min	GB/T 1843	MPa	22
Charpy Impact strenght	2.75J	GB/T 1843	kJ/m2	120

Note: All splines are printed under the following conditions: printing temperature=210 ° C, printing speed=100mm/s, base plate 40° C, filling=100%, nozzle diameter=0.4mm

# TENSILE TESTING SPECIMEN

ISO 527,GB/T 1040

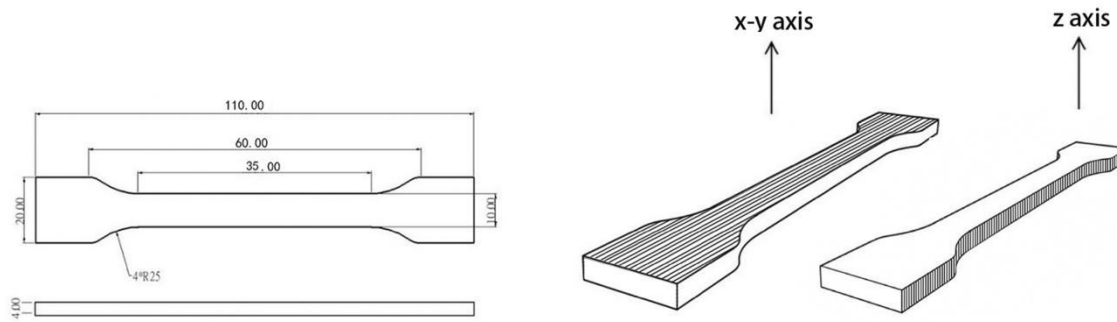

# FLEXURAL TESTING SPECIMEN

ISO 178,GB/T 9341

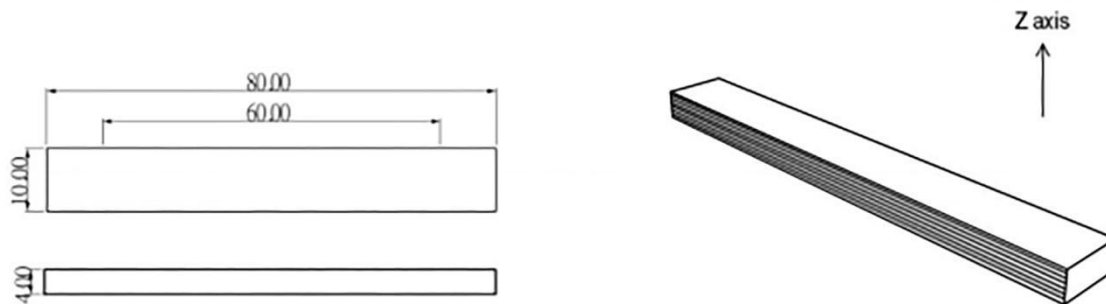

# IMPACT TESTING SPECIMEN

ISO 179,GB/T 1043

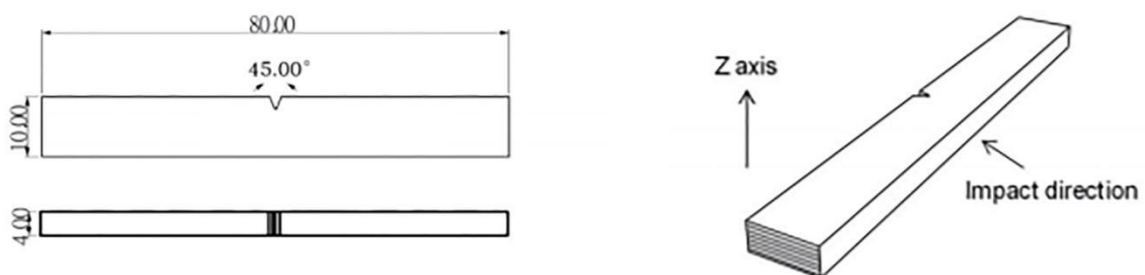

## Disclaimers

The values given in this data table are for reference and comparison only. They should not be used for design specifications or quality control. The actual value may vary depending on the printing conditions. The final performance of printed components depends not only on the material, but also on the component design, environmental conditions, printing conditions, and so on. Product specifications are subject to change without prior notice.