

SHR2DN

Intelligent Motor Soft Starter

Selection Features :

- It features an LCD display with multi - language support and allows parameter setting via buttons.
- It is equipped with an RS485 bus interface and supports Modbus/Profibus protocols.
- It has programmable digital inputs and outputs.
- It offers perfect start - stop control and protection functions.
- It can operate continuously online without a bypass, boasting high reliability.

specification

Main power supply	230V~690VAC 50/60Hz
Control power supply	110V~120VAC 50/60Hz 220~240VAC 50/60Hz
Control input signal	110~120VAC 50/60Hz 220~240VAC 50/60Hz
Main current	18~840A
Starting time	1~30s (extendable to 90s)
Stopping time	1~30s (extendable to 90s)
Initial voltage	10~50%Un (extendable to 80%Un)
Current limiting multiple	100%~400%FLA (extendable to 500%)
Starting frequency	4 times per hour at the maximum starting current
Pulse starting	80%Un for a duration of 0~1s
Low-speed operation time	≤30s
Pump control curve	6 pieces
Speed feedback curve	12 pieces
Display language type	4 languages can be optionally selected

Note: Please contact the manufacturer to set the parameters.



The SHR2DN is an intelligent motor soft starter with voltage regulation and current limiting functions, equipped with a digital processor. Its unique intelligent electronic circuit offers perfect control and protection features: linear acceleration starting, pump start and stop control, preset low - speed operation (short - term electronic control of forward and reverse rotation debugging at low speed is available), freely switchable dual start - stop parameters can be preset, and it can monitor the load status and automatically operate in the light - load energy - saving mode. It also has functions such as motor insulation detection protection, and protection against phase loss, short - circuit, phase sequence issues, and electronic overload.

It uses an RS 485 communication interface and supports the Modbus/Profibus protocols, enabling comprehensive remote control and monitoring via a microcomputer. It can be widely used in industries such as textile, metallurgy, petroleum, chemical engineering, water treatment, shipping, transportation, pharmaceuticals, food processing, mining, and mechanical equipment.

Motor Voltage

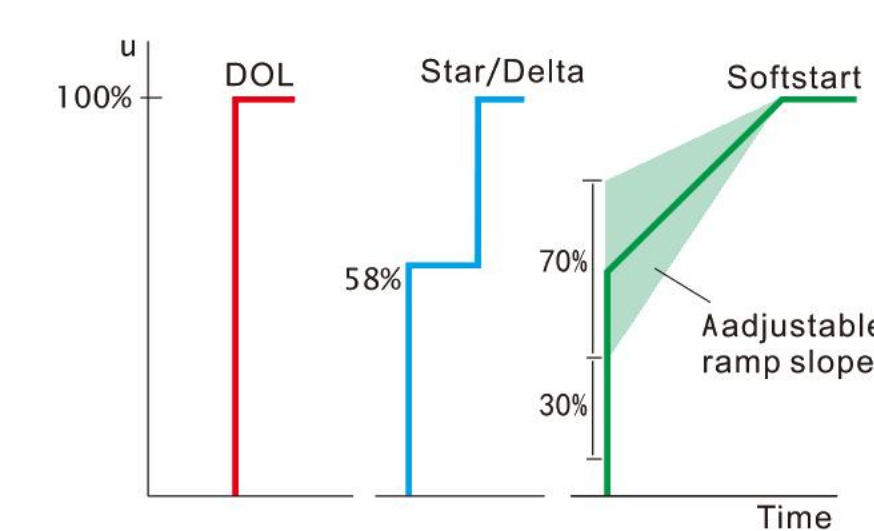

Motor current

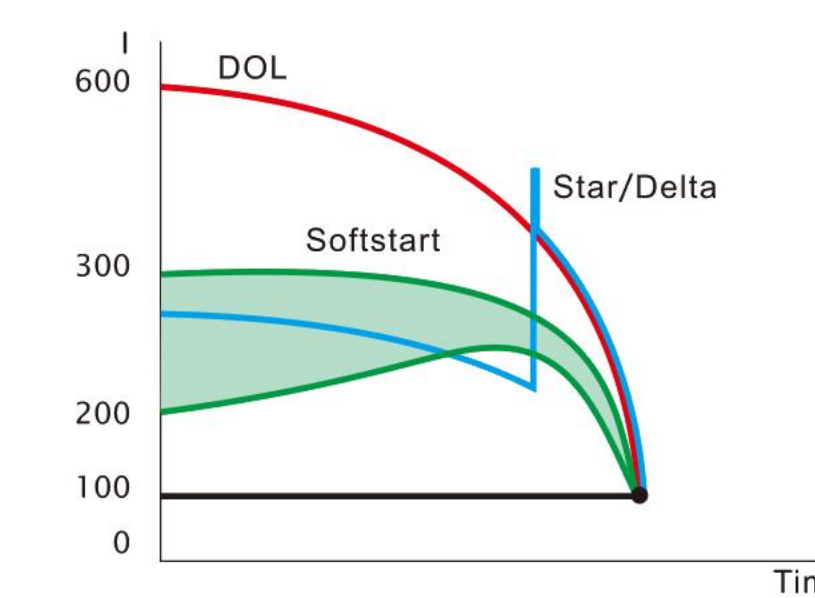

Torque

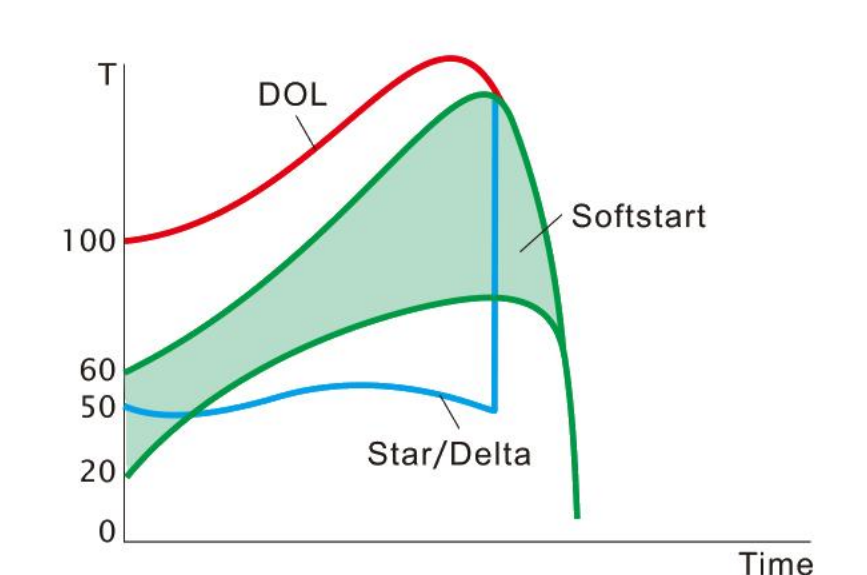

Product Selection :

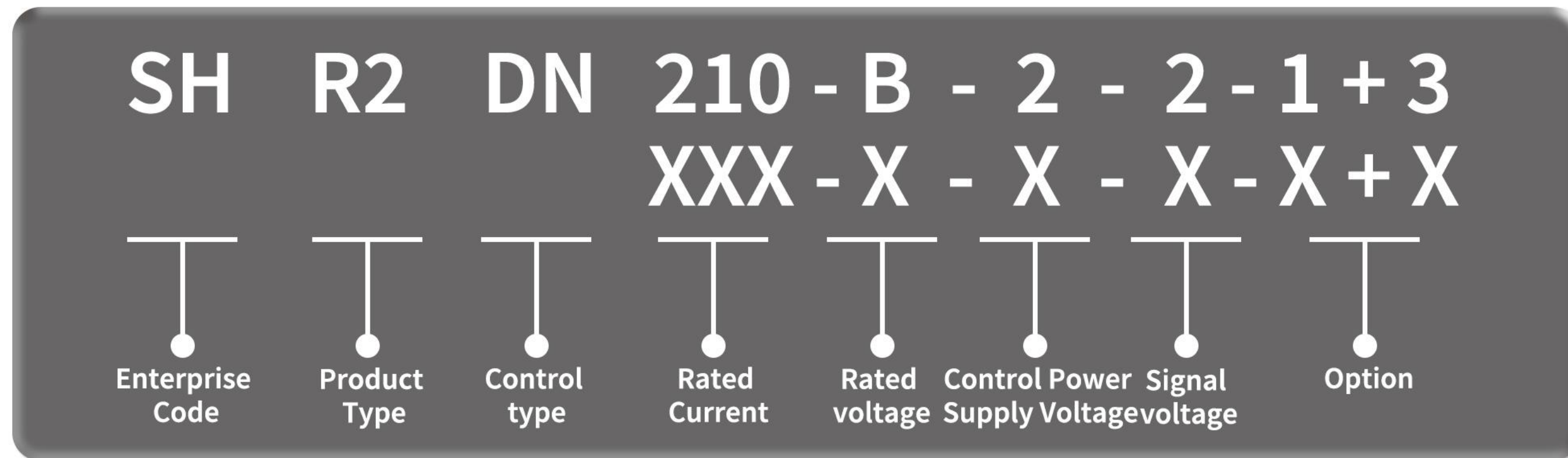

1. Rated current: 18, 30, 45, 60, 75, 90, 110, 145, 175, 210, 250, 300, 370, 470, 570, 720, 840

2. Main voltage:	Code	Nominal value	Scope of application
50/60Hz±4Hz	2 or A	230VAC	220~240VAC
	4 or B	400VAC	380~420VAC
	5 or C	500VAC	480~520VAC
	6 or D	600VAC	630~690VAC

3. Control power supply voltage:	Code	Nominal value	Scope of application
50/60Hz±4Hz	1	115VAC	110~120VAC
	2	230VAC	220~240VAC

4. Signal voltage:	Code	Nominal value	Scope of application
50/60Hz±4Hz	1	115VAC	110~120VAC
	2	230VAC	220~240VAC

5. Option function:	Code	Function Introduction
You can select one or more functions at a time, for example: 1+3 (communication + insulation)	0	Make no selection
	1	RS485 communication interface MODBUS protocol
	2	RS485 communication interface PROFIBUS protocol
	3	Motor insulation class detection
	4	Analog input/output function
	5	Special protection treatment for harsh working environments
	7	The control panel can be installed remotely

Notes:

- For the same soft starter, only one option can be selected between #1 and #2.
- For the same soft starter, only one option can be selected between #3 and #4.

Product Selection :

The maximum power of the motor				Rated current range	Specifications and models of soft starters				
230V	400V	500V	690V	A	Model	Main voltage	Control voltage	Control input voltage	Option function
4	7.5	11	15	9-18	SHR2DN18	-X	-X	-X	X+X
7.5	15	18.5	25	15-30	SHR2DN30	-X	-X	-X	X+X
15	22	25	37	23-45	SHR2DN45	-X	-X	-X	X+X
18.5	30	37	55	30-60	SHR2DN60	-X	-X	-X	X+X
22	37	45	59	38-75	SHR2DN75	-X	-X	-X	X+X
25	45	55	75	45-90	SHR2DN90	-X	-X	-X	X+X
30	55	75	90	55-110	SHR2DN110	-X	-X	-X	X+X
37	75	90	132	73-145	SHR2DN145	-X	-X	-X	X+X
45	90	110	160	88-175	SHR2DN175	-X	-X	-X	X+X
55	110	132	200	105-210	SHR2DN210	-X	-X	-X	X+X
75	132	160	220	125-250	SHR2DN250	-X	-X	-X	X+X
90	160	200	257	150-300	SHR2DN300	-X	-X	-X	X+X
110	200	250	355	185-370	SHR2DN370	-X	-X	-X	X+X
132	250	315	450	235-470	SHR2DN470	-X	-X	-X	X+X
160	315	400	560	285-570	SHR2DN570	-X	-X	-X	X+X
200	400	500	710	360-720	SHR2DN720	-X	-X	-X	X+X
250	450	560	800	420-840	SHR2DN840	-X	-X	-X	X+X

Selection Guidance

In applications with normal loads, such as pumps, compressors, elevators, lifts, short - distance conveyors and bow thrusters, the SHR2DN soft starter can be selected according to the rated power of the motor. For applications with heavy loads, such as centrifuges, compressors, mixers, agitators and long - distance conveyors, it is recommended that you select a soft starter with a rating one level higher than the rated power of the motor.

Technical data:

General information	
Main power supply voltage	Main voltage: 230 - 690VAC (to be specified by the user); default voltage is 400VAC.
Frequency	50/60Hz±4Hz (dual frequency); default frequency is 50±4Hz.
Control power supply voltage	110 - 120VAC or 220 - 240VAC (to be specified by the user); default voltage is 220VAC.
Control input signal voltage	110 - 120VAC or 220 - 240VAC (to be specified by the user); default voltage is 220VAC.
Load	Three - phase three - wire squirrel - cage induction motor.
Operating temperature	0°C to 50°C.
Storage temperature	-20°C to 70°C.
Maximum starting time (*)	30 seconds.
Maximum number of starts per hour	At 400% FLA (Full - Load Amperage of the motor), 4 times per hour; in light - load applications, it can reach 60 times per hour.

Technical data:

• Work parameters

Starter FLC	Starter full load current: 18 - 840 A
Motor FLA	The motor full load current can be selected between 50% - 100% of the starter FLC.
Pump control curve	6 curves are available to prevent over - water pressure during pump startup and water hammer effect during pump shutdown.
Pulse start	Use a voltage pulse of 80% Un, and the pulse time can be adjusted from 0 - 1 second, which is used to start high - static - friction loads.
Initial voltage (*)	It can be set from 10% - 50% Un (expandable to 80% Un).
Current limit ("))	It can be set from 100% - 400% of the motor FLA (expandable to 500%).
Start ramp-up time (*)	Adjustable from 1 - 30 seconds (expandable to 90 s).
Stop ramp-down time (*)	Adjustable from 1 - 30 seconds (expandable to 90 s).
Dual regulation	Dual start/stop parameter settings for initial voltage, current limit, acceleration time, deceleration time, and motor FLA.
Energy saving	When the motor is under a light load for a long time, the energy - saving function is activated.
Low-speed torque	Make the motor operate at 1/6 of the normal speed, generating maximum torque for up to 30 seconds.
Speed feedback and linear acceleration	12 curves are available, and the linear gain of the motor speed is controlled through speed feedback.
Starting powered by diesel generator	Enable special starting characteristics through a built - in DIP switch (dual adjustment can also be carried out through terminal 8).

• Control

Display	An (LCD) liquid crystal display that can be optionally selected in four languages and 8 (LEDs) light - emitting diodes.
Button	6 clear setting keys, which make it convenient to view and set parameters.
The working status relay operates when starting.	1C/0, 8A, 250V AC., 2000VA (with a delay of 0 - 60 seconds)
The full voltage signal relay operates at full voltage.	1C10, 8A, 250V AC., 2000VA (with a delay of 0 - 120 seconds)
The fault signal relay operates in case of a fault.	1C/0, 8A, 250V AC., 2000VA (such as tripping due to a trip or fuse failure)
Insulation alarm and tripping relay (optional)	1C/0, 8A, 250V AC., 2000VA
Communication (optional)	RS485 interface, using Modbus/ProfibusDP protocol to achieve comprehensive control and monitoring.

• Motor protection

Starting frequency limit	Maximum allowable number of starts within the set starting cycle: In a 1 - 60 minute starting cycle, 1 - 10 starts are allowed.
Starting prohibited	After the "start too frequent" indication, the starting prohibition time is adjustable within 1 - 60 minutes to prevent restarting.
Excessive starting time (stall protection) ("))	If the motor does not reach full speed within the set maximum starting time (1 - 30 seconds), the starter automatically trips to stop and protect.
Electronic fuse	When the starting current reaches 850% FLA or the running current reaches 200% - 850% FLA, the starter trips within one cycle.
Electronic overload (12t)	It can be set at 75% - 150% FLA, and the overload curve can be selected by setting the tripping time, with 1 - 10 seconds at 500% FLA.
Under-current	When the main current drops below 20% - 90% FLA, with a time delay of 1 - 40 seconds, the starter trips.
Under-voltage (*)	When the main voltage drops below 120 - 600V, with a time delay of 1 - 10 seconds, the starter trips.
Over-voltage	When the main voltage rises above 150 - 750V, with a time delay of 1 - 10 seconds, the starter trips.
Phase loss (low/high frequency) (**)	When 1 to 2 phases are missing, or the frequency deviates more than +4Hz from the normal frequency, the starter trips.
Phase sequence	When the phase sequence is incorrect, the starter trips.
Excessive low-speed time	When running at low speed exceeds the "maximum low - speed running time" (1 - 30 seconds), the starter trips.
Wiring error	If the motor is not correctly connected to the starter, starting is prohibited.
SCR short circuit	When one or more thyristors are short - circuited, starting is prohibited.
Heat sink overheating	When the heat sink temperature is higher than 85°C, the starter trips for protection.
External fault	After the external fault contact is closed for 2 seconds, the starter trips for protection.
Motor insulation level (option)	The alarm point is set between 0.2 - 5MΩ. When the motor insulation decreases to less than 0.2 - 5MΩ, starting is prohibited.
SCR protection	Metal oxide varistors protect thyristors from damage caused by instantaneous high - voltage impacts.
Analog input/output	Motor overheating signal input: Analog signal output reflecting motor current.

Note:

The extendable range requires contact with the manufacturer.

It can be set to auto - reset.

Product structure dimensions:

SHR2DN18-145

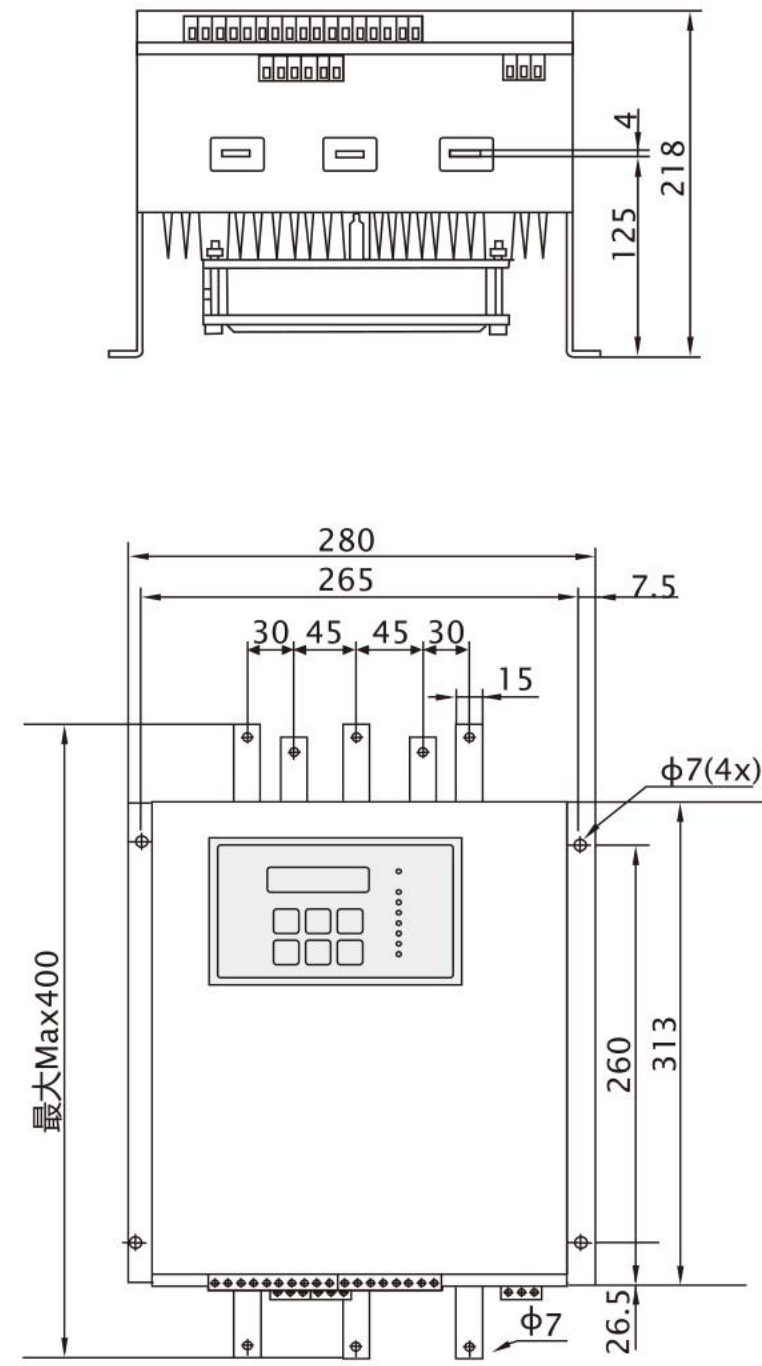

SHR2DN175-250

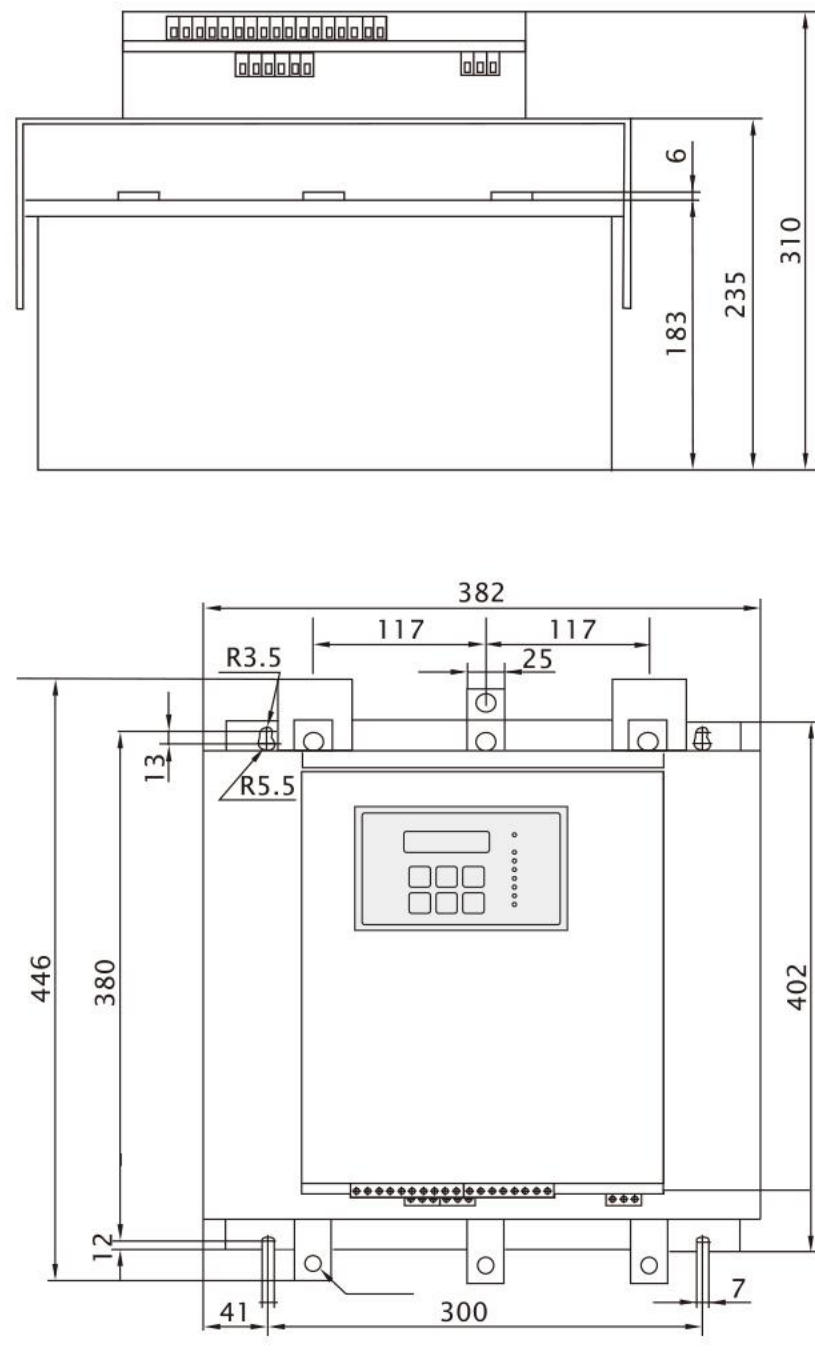

SHR2DN300-840

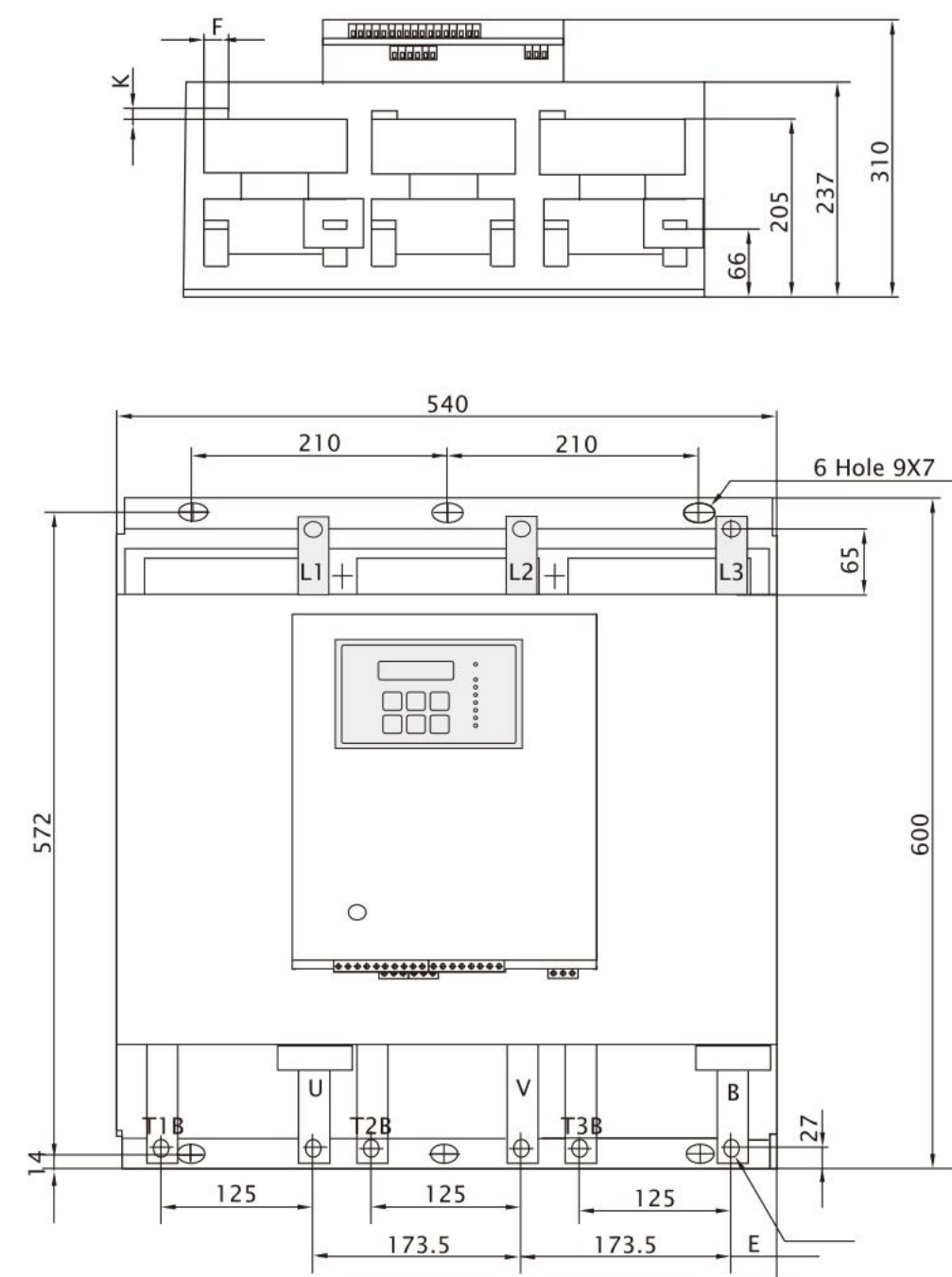

Wiring Diagram:

