

2-Way Pneumatic PVC Ball Valve

INSTRUCTION MANUAL



dc DELCO

Specialized Control Valve Manufacturer



Introduction

The UPVC pneumatic ball valve adopts a double threaded socket connection, which can be quickly assembled without the need for special tools. It has the advantages of compact structure, wear resistance, easy disassembly, convenient maintenance, and simple operation. The UPVC pneumatic ball valve body material is hygienic, non-toxic, highly corrosion-resistant, lightweight, and has a wide range of applications, such as pipeline systems for pure water and drinking water, drainage and sewage pipeline systems, saltwater and seawater pipeline systems, acid-base and chemical solution systems, and many other industries.

Main Parts Materials

UNIT:mm

NO.	Component	Material
1	Stem	SS304、304L、316、316L
2	Ball	UPVC/PPH/CPVC/PVDF
3	Body	UPVC/PPH/CPVC/PVDF
4	Endconnector	UPVC/PPH/CPVC/PVDF
5	Union Nut	UPVC/PPH/CPVC/PVDF
6	O-Ring	PTFE
7	Seat Seal	EPDM/FPM
8	Seat	UPVC/PPH/CPVC/PVDF
9	O-Ring	EPDM/FPM
10	Screw	304 SS304
11	Connecting Yoke	304 SS304
12	Connecting Set	304 SS304
13	Pneumatic Actuator	AT Series
14	Location Indicator	Plastic

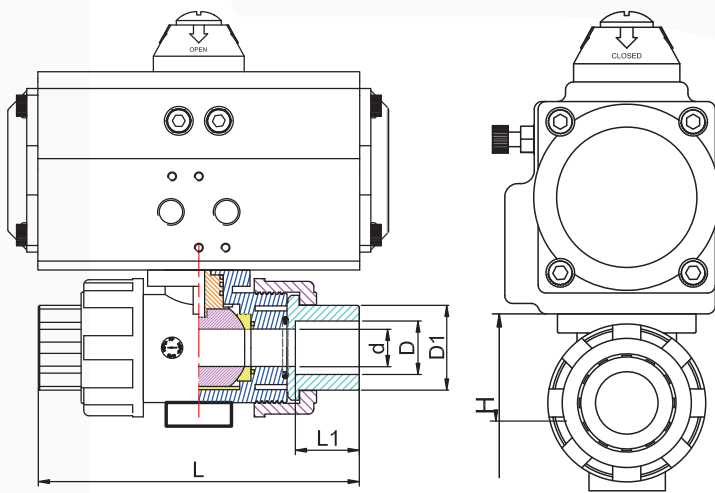

Dimension

MODEL	DN15	DN20	DN25	DN32	DN40	DN50	DN65	DN80	DN100	DN125	DN150	DN200	
G	1/2"	3/4"	1"	1-1/4"	1-1/2"	2"	2-1/2"	3"	4"	5"	6"	8"	
GB= DIN	d	16	20	25	30	38	50	63	78	100	125	150	200
	D	20	25	32	40	50	63	75	90	110	141.3	168.3	225
ANSI	d	16	20	25	30	38	50	63	78	100	125	150	200
	D	21.3	26.7	33.4	42.2	48.3	60.3	73	88.9	114.3	141.3	168.3	219
JIS	d	16	20	25	30	38	50	63	78	100	125	150	200
	D	22	26	34	42	48	60	76	89	114	140	165	216
UK	d	16	20	25	30	38	50	63	78	100	125	150	200
	D	22	26	34	42	48	60	76	89	114	140	165	216
D1	30	36	45	55	64	77	96	112	141				
L1	22.8	25	28.5	32	34.8	39	46	48	64.5				
L	121.8	134.5	150.2	166.8	179	205	233	257	309				
H	61	74	90	104	121	146	169	220	255				

Uses and Structural Features of Product

Pneumatic ball valve series are widely used in natural gas, oil, chemical industry, metallurgy, papermaking, power, mining, printing and dyeing, biological pharmacy, daily chemicals, foodstuff and beverage, water treatment and air treatment etc. For the automatic or adjustment control of fluid, together with automatic pneumatic meters.

The Structural Features of Pneumatic Ball Valves Series:

Pneumatic Actuator uses new-style AT pneumatic actuator, provided with both double-acting and single-acting types (spring reposition), driven by gear and rack with high dependability; big diameter valves are driven by AW pneumatic actuator on pul-extraction manner, with reasonable structure and large output torque as well as both double-acting and single-acting types (spring reposition). Refer to our stylebook of pneumatic actuator for more details information.

- **Shell Structure:** As per users' requirements and real working conditions, fixed ball valves can be designed to three structures including cast, forged and full welded, and valves of full-welded structure are mainly applicable for buried use.

Unique Sealing Structure of Valve Base: Floating ball valve adopts the structure of lip-type elastic sealing ring to insure the sealing dependability. For ball valves used in low-tension, ultra-low-tension or vacuum conditions, the valve-base sealing structure with leaf spring loading is adopted to maintain long-time reliable sealing. The valve-base of high-or medium-temperature ball valve may use para-position polyphenylene or metal material.

According to the difference in pressure, medium character and sealing requirements, fixed ball valve may choose structures of front-ball sealing back-ball sealing or front-back double sealing. The valve base of high-or medium-temperature ball valve may use para-position polyphenylene or metal material.

- **Obstruction and Drainage:** When valve is in off-position, the valve bases at upper and lower stream will interdict the fluid, and the deposit in the cavity may be discharged by drainage device.

Automatic Pressure-relieving Structure: In case of abnormal rise of pressure occurred in clack cavity, the mediums in it may drive the valve base with its self-thrust to realize automatic pressure relief, thus to ensure the safety of valve body.

- **Reliable Sealing of Stem:** Valve stem adopts the downward installation structure with back seating. The sealing power increases along with the rise of medium pressure, thus to ensure reliable sealing of valve stem, in addition, stem will not burst forth in case of abnormal pressure rise.

- **Fireproof Structure:** Fireproof structure may be adopted for ball valve as per working conditions and users' requirements. The fireproof design conforms to API 6D and JB/T6899 standards etc. In case of soft seating ring being damaged in fire, the fireproof structure can stop the large leakage of medium, thus to avoid further expansion of fire.

- **Anti-static Structure:** When operating, the friction between sphere and base may cause static charge accumulated on the sphere. To avoid static spark, static device is provided on the valve to educt the electric charge on the sphere.

- **Full Bore Structure and Reduced Bore Structure:** These two series are offered to meet users' different requirements. The passage inside diameter of full bore ball valve is the same as that of pipe, making it convenient for control and cleaning. The weight of reduced bore ball valve is relatively smaller, but the fluid resistance is only around 1/7 of that of stop valve with the same caliber. Therefore, the application prospect is much better for the latter.

Products Performance Specification

Pressure grade		Nominal Pressure PN(MPa)					Pound(Class)			
		1.6	2.5	4.0	6.4	10.0	150	300	400	600
Test Pressure (MPa)	Shell test	2.4	3.75	6.0	9.6	15.0	3.03	7.5	10.2	15.0
	Sealing test	1.76	2.75	4.4	7.04	11.0	2.2	5.5	7.48	11.0
	Air Sealing Test	0.6 (MPa)								
Applicable medium		Material of Valve Body								
		CARBON STEEL			STAINLESS STEEL 304			STAINLESS STEEL 316		
		Water, Steam, oil and liquefied gas etc.			Corrosive mediums such as nitric acid etc			Corrosive mediums such as nitric acid etc		
Special Medium		Natural gas containing sulphureted hydrogen; transportation system for coal powder or aluminum powder used for the smelting of steel and non-ferrous metal; mediums used for the transportation of paper pulp in papermaking industry as well as other mediums containing granules or staple fiber etc.								

Double Acting Actuators

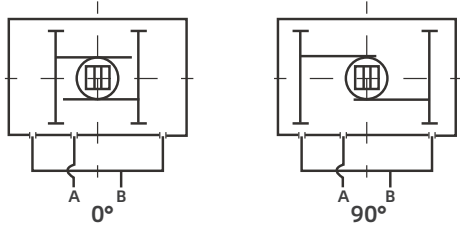
CCW PN (MPa)

Air to Port A forces the pistons outwards, causing the pinion to turn counterclockwise while the air is being exhausted from Port B.
 Air to Port B forces the pistons inwards, causing the pinion to turn clockwise while the air is being exhausted from Port A.

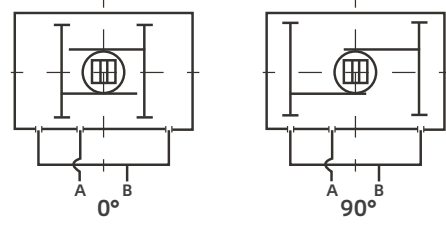
CW (Class)

Air to Port A forces the pistons outwards, causing the pinion to turn clockwise while the air is being exhausted from Port B.
 Air to Port B forces the pistons inwards, causing the pinion to turn counterclockwise while the air is being exhausted from Port A.

Output Torque of Double Acting Actuators

MODEL	Air supply pressure (Unit: Bar)									
	2	2.5	3	4	4.5	5	5.5	6	7	8
AT52DA	8.0	10.0	12.0	16.0	18.0	20.0	21.9	23.9	27.9	31.9
AT65DA	14.6	18.2	21.9	29.2	32.8	36.5	40.1	43.8	51.1	58.4
AT75DA	20.1	25.1	30.1	40.1	45.1	50.2	55.2	60.2	70.2	80.3
AT85DA	31.4	39.2	47.0	62.7	70.5	78.4	86.2	94.1	109.7	125.4
AT92DA	45.1	56.4	67.7	90.3	101.6	122.9	124.1	135.4	158.0	180.6
AT105DA	66.1	82.7	99.2	132.2	148.8	165.3	181.8	198.4	231.4	264.5
AT125DA	100.3	125.4	150.5	200.6	225.7	250.8	275.9	301.0	351.1	401.3
AT140DA	171.0	213.8	256.5	342.0	384.8	427.5	470.3	513.0	598.5	684.0
AT160DA	266.0	332.5	399.0	532.0	598.5	665.0	731.5	798.0	931.0	1064.0
AT190DA	425.6	532.0	638.4	851.2	957.6	1064.0	1170.4	1276.8	1489.6	1702.4
AT210DA	532.0	665.0	798.0	1064.0	1197.0	1330.0	1463.0	1596.0	1862.0	2128.0
AT240DA	769.5	961.9	1154.3	1539.0	1731.4	1923.8	2116.1	2308.5	2693.3	3078.0
AT270DA	1169.6	1462.1	1754.5	2339.3	2631.7	2924.1	3216.5	3508.9	4093.7	4678.6

Selection of Double Acting Actuator:

The suggested safety factor for double acting actuators under normal working conditions is 20%-30%.

Example:

- The torque needed by valve=100N.m
- The torque considered safety factor(1+30%)=130N.m
- Air Supply=5Bar

According to the above table, we can choose the minimum model is AT160DA.

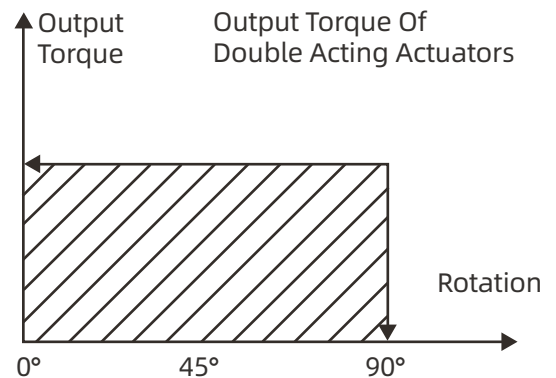

Spring Acting Actuators

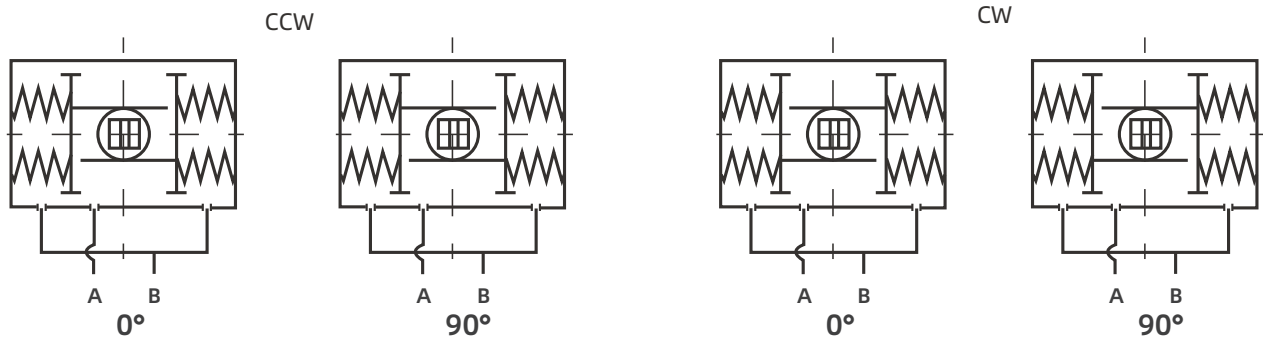

Air to port A forces the pistons outwards, causing the springs to compress. The pinion turns counter clockwise while air is being exhausted from port B.

Loss of air pressure on port A, the stored energy in the springs forces the pistons inwards. The pinion turns clockwise while air is being exhausted from port A.

Air to port B forces the pistons outwards, causing the springs to compress. The pinion turns counter clockwise while air is being exhausted from port B.

Loss of air pressure on port B, the stored energy in the springs forces the pistons inwards. The pinion turns clockwise while air is being exhausted from port A.

Output Torque of Spring Return Actuators

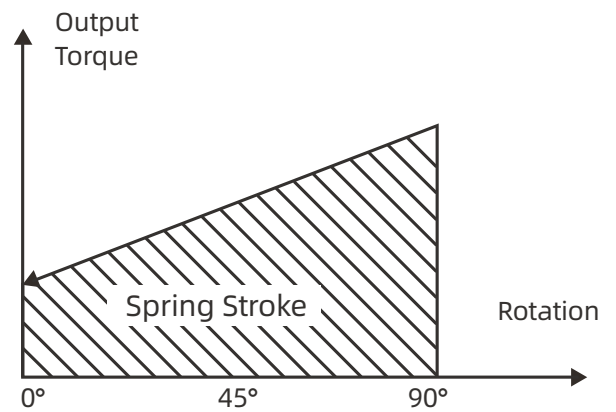
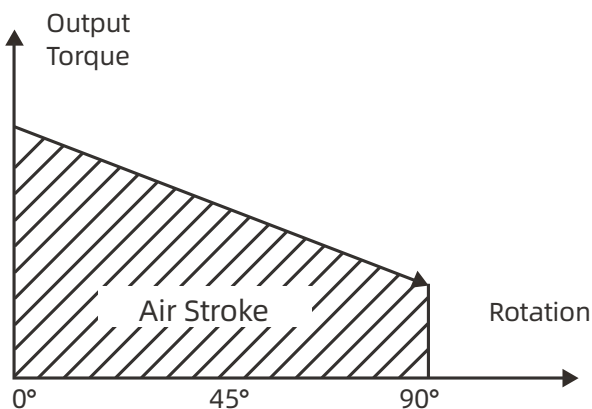

NOTE:

Make sure that the torque necessary to operate the valve is compatible with the actuator torque (It depends on both actuator type and air supply).

Please note that the requested torque depends not only on the valve, but on the working conditions and the safety margins of the plant in question, too.

Output Torque of Spring Return Actuators (UnitLN.m)

Output Torque of Air to Springs																	Springs/output	
Air Pressure	2.5Bar		3Bar		4Bar		5Bar		6Bar		7Bar		8Bar					
Model	Spring Q.ty	0°	90°	0°	90°	0°	90°	0°	90°	0°	90°	0°	90°	0°	90°	0°	90°	
		Start	End	Start	End	Start	End	Start	End	Start	End	Start	End	Start	End	Start	End	
AT52SR	5	5.7	3.8	7.6	5.7												6.2	4.3
	6	4.9	2.5	6.9	4.5	10.9	8.5										7.4	5.0
	7	4.0	1.3	6.0	3.3	9.8	7.3	14.0	10.4								8.6	5.9
	8			5.2	2.0	9.2	6.0	13.2	9.1	17.2	14.1						9.9	6.7
	9			4.3	0.8	8.3	4.8	12.3	7.9	16.3	12.8	20.3	16.8				11.1	7.6
	10					7.4	3.6	11.5	6.7	15.5	11.6	19.5	15.6				12.4	8.5
	11					6.6	2.3	10.6	5.4	14.6	10.4	18.6	14.3	22.6	18.3		13.6	9.3
	12								9.7	4.2	13.8	9.1	17.8	12.2	21.8	17.1		14.8
AT65SR	5	11.4	7.7	15.0	11.4	22.3	14.9										10.4	6.8
	6	10.1	5.7	13.6	9.3	20.9	16.6	28.3	23.9								12.5	8.2
	7	8.6	3.6	12.5	7.2	19.5	14.5	26.8	21.9								14.6	9.6
	8			10.9	5.1	18.2	12.4	25.5	19.8	32.8	27.0	40.1	34.3				16.7	10.9
	9					16.8	10.4	24.1	17.7	31.4	24.9	38.7	32.2				18.8	12.3
	10					1.4	8.2	22.8	15.6	30.0	22.8	37.3	30.1	44.7	37.4		20.9	13.7
	11							21.5	13.5	28.7	20.7	34.6	28.0	43.3	35.3		22.9	15.0
	12							20.0	11.4	27.3	18.6	34.6	25.9	41.9	33.3		25.0	16.4
AT75SR	5	14.5	10.6	19.4	15.5	29.5	25.7										14.5	10.5
	6	12.4	7.6	17.3	12.6	27.4	22.7	37.5	32.8								17.4	12.7
	7	10.4	4.8	15.2	9.7	25.3	19.9	35.4	29.9								20.3	14.8
	8			13.1	6.8	23.1	16.9	33.3	27.0	43.2	37.0	53.3	47.0				23.2	16.9
	9					21.0	14.1	31.2	24.1	41.1	34.1	51.2	44.2				26.1	19.0
	10					19.0	11.1	28.8	21.2	39.0	31.2	49.1	41.2	59.1	51.2		29.0	21.1
	11							27.0	18.3	37.0	28.3	47.0	38.4	57.0	48.4		31.9	23.2
	12							24.9	15.4	34.9	25.4	44.9	35.4	54.9	45.4		34.7	25.3
AT85SR	5	23.3	16.1	31.1	24.0	46.8	39.7										23.0	15.8
	6	20.1	11.5	28.0	19.3	43.7	35.1	59.4	50.7								27.6	19.0
	7	17.0	6.9	24.8	14.8	40.5	30.5	56.2	46.2								32.2	22.1
	8			21.7	10.1	37.4	25.8	53.1	41.5	68.8	57.2	84.5	72.9				36.8	25.3
	9					34.2	21.3	49.9	37.0	65.6	52.6	81.2	68.3				41.4	28.5
	10					31.0	16.6	46.7	32.3	62.4	48.0	79.1	63.7	93.8	79.3		46.0	31.6
	11							43.6	27.7	59.3	43.4	75.0	59.1	90.6	74.8		50.6	34.8
	12							40.4	23.2	56.1	38.9	71.7	54.5	87.4	70.2		55.2	38.0
AT92SR	5	33.1	22.0	44.2	33.2	66.8	55.9										34.4	23.3
	6	28.4	15.2	39.6	26.4	62.2	49.0	84.8	71.6								41.2	28.0
	7	23.8	8.2	34.9	19.4	57.5	42.1	80.2	64.7								48.1	32.7
	8			31.3	12.6	52.9	35.2	75.5	57.9	98.1	80.5	120.7	103.0				55.0	37.3
	9					48.2	28.4	70.9	51.0	93.5	73.6	116.0	96.1				61.9	42.0
	10					43.6	21.5	66.2	44.1	88.8	66.7	111.3	89.2	134.0	111.8		68.7	46.7
	11							61.5	37.2	84.1	59.9	106.6	82.4	129.2	105.0		75.6	51.4
	12							56.8	30.4	79.4	53.0	101.9	75.5	124.5	98.1		82.5	56.0
AT105SR	5	51.0	33.4	67.5	49.9	100.6	83.0										49.2	31.6
	6	44.7	23.5	61.1	40.0	94.2	73.2	127.3	106.2								59.1	38.0
	7	38.4	13.7	54.9	30.3	87.9	63.4	121.0	96.4								68.9	44.3
	8			48.5	20.4	81.6	53.5	114.7	86.5	147.7	119.6	180.8	152.7				78.7	50.6
	9					75.3	43.7	108.4	76.8	141.5	109.8	174.5	142.9				88.6	56.9
	10					68.9	33.4	102.0	66.5	135.1	99.6	168.2	132.6	201.2	165.7		98.4	63.3
	11							95.7	57.0	128.7	90.1	161.8	123.1	194.8	156.2		108.3	69.6
	12							89.4	47.5	122.5	80.6	155.5	113.6	188.6	146.7		118.1	75.9

Output Torque of Spring Return Actuators (UnitLN.m)

Output Torque of Air to Springs																	Springs'output	
Air Pressure		2.5Bar		3Bar		4Bar		5Bar		6Bar		7Bar		8Bar				
Model	Spring Q.ty	0°	90°	0°	90°	0°	90°	0°	90°	0°	90°	0°	90°	0°	90°	0°	90°	
		Start	End	Start	End	Start	End	Start	End	Start	End	Start	End	Start	End	Start	End	
AT125SR	5	73	47	98	72	148	122									79	52	
	6	63	31	88	56	138	107	188	157							94	63	
	7	52	15	77	40	127	90	178	141							110	73	
	8			67	25	117	75	167	125	217	176	268	226			125	84	
	9					107	59	157	109	207	159	257	210			141	94	
	10					96	44	146	94	196	144	247	194	297	245	157	105	
	11							136	78	186	128	236	178	286	228	173	115	
AT140SR	5	128	85	171	127	256	213									129	86	
	6	111	59	154	102	239	187	325	273							155	103	
	7	94	33	137	76	222	162	308	247							181	120	
	8			120	50	205	136	291	221	376	307	462	392			206	137	
	9					187	110	273	196	358	281	444	367			232	155	
	10					170	84	256	169	341	255	427	340	512	426	258	172	
	11							238	143	324	229	409	314	495	400	284	189	
AT160SR	5	193	124	259	191	392	324									208	140	
	6	165	83	232	149	365	282	498	415							250	168	
	7	137	41	203	107	336	240	469	373							292	196	
	8			176	66	309	199	442	237	575	465	709	598			333	223	
	9					280	157	413	290	546	423	679	556			375	251	
	10					253	115	386	248	519	381	652	514	785	647	417	279	
	11							358	207	491	340	624	473	757	606	458	307	
AT190SR	5	332	222	438	329	651	542									309	200	
	6	292	161	398	267	611	480	824	693							371	240	
	7	252	99	358	205	571	418	784	631							433	280	
	8			318	143	531	356	744	569	957	782	1169	995			495	320	
	9					491	295	704	507	917	720	1130	933			557	360	
	10					451	233	664	446	877	658	1090	871	1302	1084	618	400	
	11							624	384	837	597	1050	809	1263	1022	680	440	
AT210SR	5	390	285	523	418	789	684									380	275	
	6	335	209	468	342	734	608	1000	874							456	330	
	7	280	133	413	266	679	532	945	798							532	385	
	8			358	190	624	456	890	722	1156	988	1422	1254			608	440	
	9					569	380	835	646	1101	912	1367	1178			684	495	
	10					514	304	780	570	1046	836	1312	1102	1578	1368	760	550	
	11							725	494	991	760	1257	1026	1523	1292	836	605	
AT240SR	5	552	409	744	600	1129	985									554	410	
	6	470	297	662	489	1047	874	1432	1259							665	492	
	7	388	187	580	379	964	764	1349	1149							775	575	
	8			498	268	883	653	1267	1037	1652	1422	2037	1807			886	656	
	9					800	542	1185	926	1569	1311	1954	1696			998	739	
	10					718	431	1103	816	1488	1201	1872	1586	2257	1970	1108	812	
	11							1021	705	1406	1090	1791	1474	2176	1859	1219	903	
AT270SR	5	903	675	1195	968	1779	1552									787	560	
	6	790	519	1083	811	1667	1396	2252	1981							943	672	
	7	679	361	972	654	1556	1238	2141	1823							1101	783	
	8			860	497	1444	1081	2029	1666	2614	2252	3199	2836			1258	895	
	9					1332	923	1917	1509	2502	2094	3087	2678			1416	1007	
	10					1220	767	1805	1352	2390	1937	2974	2521	3560	3107	1572	1119	
	11							1693	1194	2278	1779	2862	2364	3448	2949	1730	1231	
12							1582	1037	2167	1623	2751	2207	3336	2792	1887	1342		

Selection of Single Acting Actuator

The suggested safety factor for spring return actuator under normal working conditions is 30%-50%.

Example:

The torque needed by valve=80N.m

The torque consider safety factor=80(1+30%)=104N.m

Air Supply=5Bar

According to the table of spring return actuators' output, we find output torque of AT140SR K7 is: Air stroke 0° =308N.m

Air stroke 90° =247N.m

Spring stroke 90° =181N.m

Spring stroke 0° =120N.m

All the output torque is larger than we needed.

Attention:

During the spring reset of the single acting actuator, the actuator B port ventilation does not affect the actuator output torque, instead, it helps the spring reset.



5 Springs

6 Springs



7 Springs

8 Springs

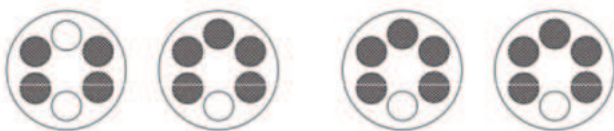

9 Springs

10 Springs



11 Springs

12 Springs

During selecting the spring return actuators, we can choose the more reasonable and more economical actuators, if we know the different torque needed by the valve working at opening, operating and closing.

Example:

The max torque needed by the butterfly valve=104N.m

The torque after opened (operating) 104x30%=32N.m

Air Supply=5Bar

We can select the AT125SR K11 output torque is:

- Air stroke 0° =136N.m >104N.m
- Air stroke 90° =78N.m >32N.m
- Spring stroke 90° =173N.m >32N.m
- Spring stroke 0° =115N.m >104N.m

The above data show the actuator's torque can satisfy the requirement of the butterfly valve.

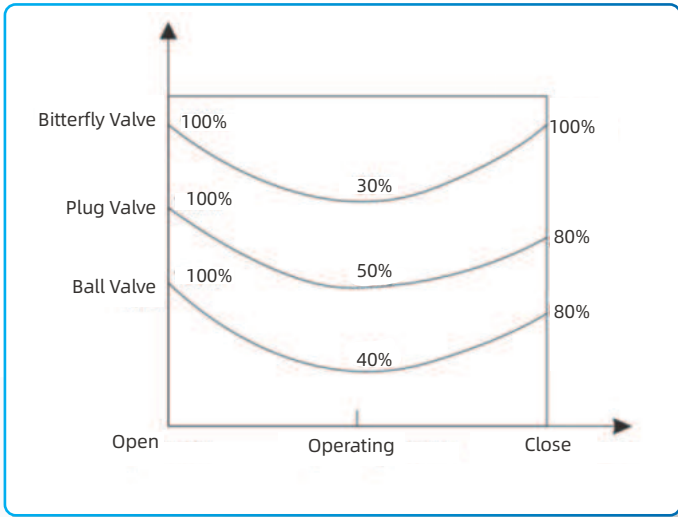

Example.

Butterfly valve original maximum torque = 104N.m

Opened torque $104 \times 30\% = 32\text{N.m}$

Air pressure=5Bar

We can choose AT125SRK11

Air stroke $0^\circ = 136\text{N.m} > 104\text{N.m}$

Air stroke $90^\circ = 78\text{N.m} > 32\text{N.m}$

Spring stroke $90^\circ = 173\text{N.m} > 32\text{N.m}$

Spring stroke $0^\circ = 115\text{N.m} > 104\text{N.m}$

The above data shows that it can meet the normal opening and closing of this butterfly valve.

Operating Conditions

1. Operating media

Dry or lubricated air, or the non-corrosive gases the maximum particle diameter must be less than $30 \mu\text{m}$.

2. Air supply pressure the minimum supply pressure is 2.5 Bar, the maximum supply pressure is 8 Bar.

3. Operating temperature

Standard: $-20^\circ\text{C} \sim +80^\circ\text{C}$

Low temperature: $-35^\circ\text{C} \sim +80^\circ\text{C}$

High temperature: $-15^\circ\text{C} \sim +150^\circ\text{C}$

4. Travel adjustment

Have adjustment range of $+5^\circ$ for the rotation at 0° and 90°

5. Application

Either indoor or outdoor.

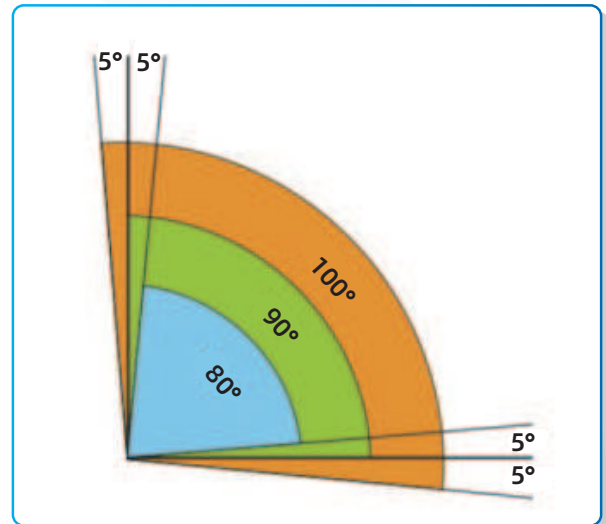

Operating Type (Single Action And Double Action)

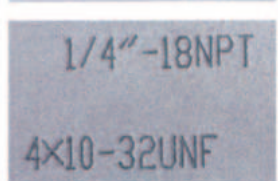
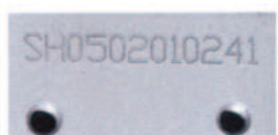

- Air supply connection is designed in accordance with NAMUR Standard to install solenoid valves.
- The Namur drive pinion and the Namur top mounting connection permit direct installation of accessories such as limit switch box and positioner.
- Bottom mounting connection is designed in accordance with ISO5211 and DIN3337 standards for direct mounting with valve gear boxes or mounting brackets
- Each actuator is marked with a serial number, air connection and bottom mounting holes are marked for easy track and distinction.

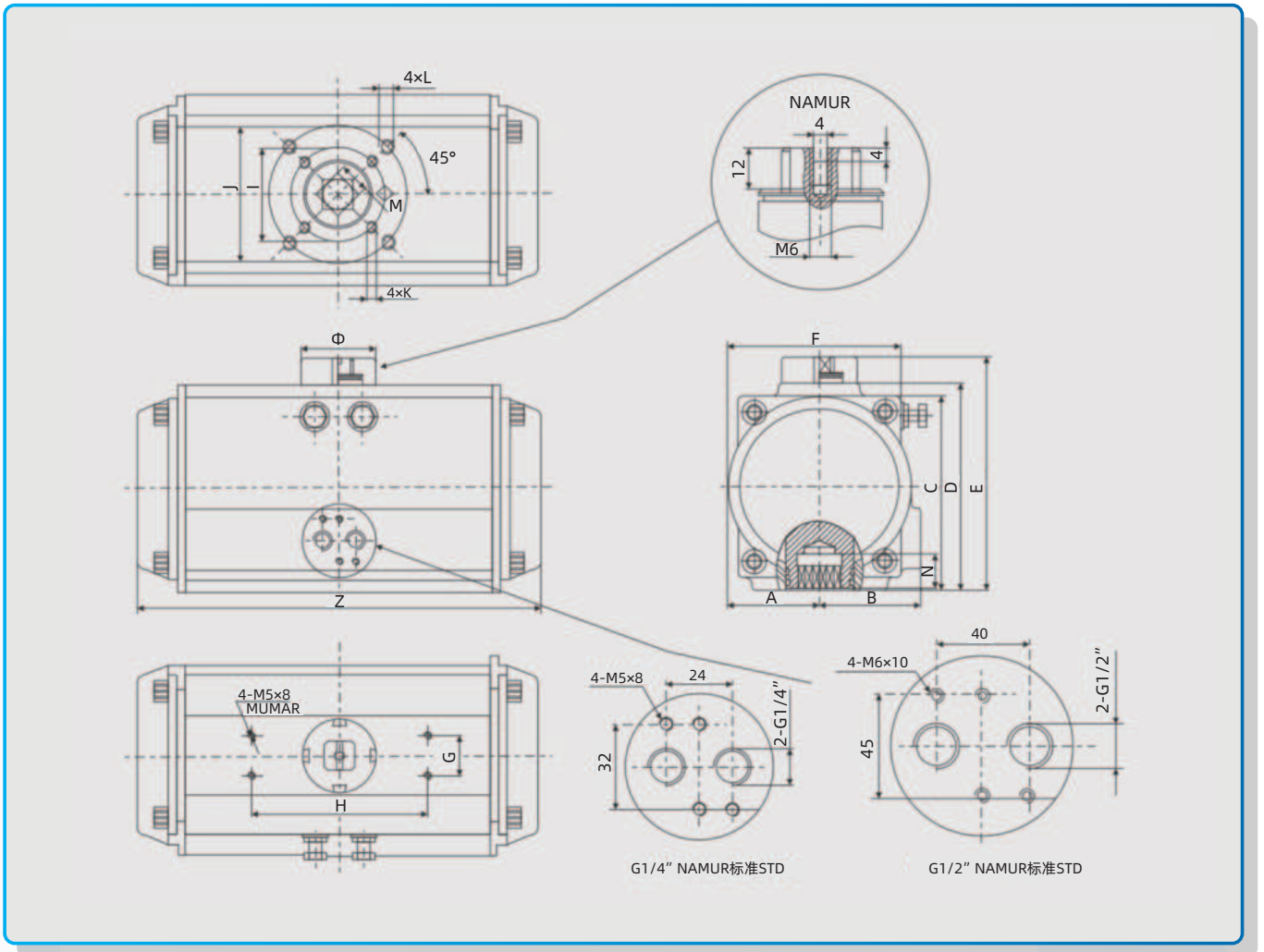

Dimension Table

MODEL	A	B	C	D	E	F	G	H	I	J	K	L	M	N	Z	Φ	Air Connection
AT52	30	41.5	65.5	72	92	65	30	80	Φ36	Φ50	4-M5×8	4-M6×10	11	14	147	Φ40	NAMUR G1/4"
AT65	37.5	46	81	89	109	73.5	30	80	Φ50	Φ70	4-M6×10	4-M8×13	14	18	170	Φ40	NAMUR G1/4"
AT75	42	53	94	100	120	81	30	80	Φ50	Φ70	4-M6×10	4-M8×13	14	18	184	Φ40	NAMUR G1/4"
AT85	46	57	98.5	108.5	128.5	92	30	80	Φ50	Φ70	4-M6×10	4-M8×13	17	21	206	Φ40	NAMUR G1/4"
AT92	50	58.5	111	116.5	136.5	98	30	80	Φ50	Φ70	4-M6×10	4-M8×13	17	21	262	Φ40	NAMUR G1/4"
AT105	57.5	64	122.5	134	154	109.5	30	80	Φ70	Φ102	4-M8×13	4-M10×16	22	26	282	Φ40	NAMUR G1/4"
AT125	71	74.5	150	160	180	133.5	30	80	Φ70	Φ102	4-M8×13	4-M10×16	22	26	304	Φ55	NAMUR G1/4"
AT140	75	77	162	174	194	137.5	30	80	Φ102	Φ125	4-M10×16	4-M12×20	27	31	396	Φ55	NAMUR G1/4"
AT160	87	87	185	198.5	218.5	158.5	30	80	Φ102	Φ125	4-M10×16	4-M12×20	27	31	445	Φ55	NAMUR G1/4"
AT190	103	103	216	232	262	189	30	130		Φ140		4-M16×25	36	50	532	Φ80	NAMUR G1/4"
AT210	113	113	235.5	257	287	210	30	130		Φ140		4-M16×25	36	50	536	Φ80	NAMUR G1/4"
AT240	130	130	264.5	292	322	245	30	130		Φ165		4-M20×25	46	60	602	Φ80	NAMUR G1/4"
AT270	147	147	299	332	362	273	30	130		Φ165		4-M20×25	46	60	722	Φ80	NAMUR G1/2"

Air Consumption

Air Volme Opening&Closing

Unit: L

MODEL	Aur Volumr Opening	Aur Volumr Closing	MODEL	Aur Volumr Opening	Aur Volumr Closing
AT52	0.12	0.16	AT140	2.5	2.2
AT65	0.21	0.23	AT160	3.7	3.2
AT75	0.3	0.34	AT190	5.9	5.4
AT85	0.43	0.47	AT210	7.5	7.5
AT92	0.64	0.73	AT240	11	9
AT105	0.95	0.88	AT270	17	14
AT125	1.6	1.4			

Air consumption rest with Air Supply. Air volume and Action cycle times,expressions:

$$L/Min = \text{Air volume}(\text{Air volume Opening} + \text{Air volume closing}) \times \left[\frac{\text{Air Supply (Kpa)} + 101.3}{101.3} \right] \times \text{Action cycle times}(/min)$$

Series	MODEL	Spring Q.ty	Options
AT <input type="checkbox"/> DA	52	K5	120°,140°,180° for special degree operation
	65	K6	
	75	K7	
AT <input type="checkbox"/> SR <input type="checkbox"/>	85	K8	
AT <input type="checkbox"/> <input type="checkbox"/> Ni	92	K9	SS Stainless Steel Pinion
	105	K10	
	125	K11	

Series	MODEL	Spring Q.ty	Options
AT <input type="checkbox"/> DA	140	K5	120°,140°,180° for special degree operation
	160	K6	
	190	K7	
AT <input type="checkbox"/> SR <input type="checkbox"/>	210	K8	
AT <input type="checkbox"/> <input type="checkbox"/> Ni	240	K9	SS Stainless Steel Pinion
	270	K10	
		K11	

Weight Table

Model	AT52Φ(52)	AT65Φ(65)	AT75Φ(75)	AT85Φ(85)	AT92Φ(92)	AT105Φ(105)	AT125Φ(125)
DA	1.38kg	2.03kg	2.7kg	3.13kg	4.6kg	6.77kg	8.9kg
SR	1.45kg	2.05kg	2.9kg	3.6kg	5.22kg	6.85kg	10.11kg

Model	AT140Φ(140)	AT160Φ(160)	AT190Φ(190)	AT210Φ(210)	AT240Φ(240)	AT270Φ(270)
DA	13.25kg	20.14kg	31.3kg	46.8kg	67.28kg	96.9kg
SR	15.55kg	24kg	35.25kg	54.8kg	80.2kg	118kg

Note: 1.SR is 12 springs; 2. Weight is net weight.

Temperature Rating of Seat Sealing Material

Code	Material	(°C) Applicable Temperature
F	Reinforced Polytetrafluoroethylene(PTFE)	-40~180
P	Para-potion polyphenylene	-40~285
Y	Hard Alloy	-40~425

According to the diferent control and the request can choose the following accessories:
 Cut-off Accessories: Single coil solenoid valve, Double electrically-controlled Solenoid valve, Limit Switch
 Adjusting Accessories: Electropneumatic positioner, Pneumatic positioner, Electric-pneumatic Converter.
 Air-supply Treatment Accessories: Air-filtering reducing valve, F.R.L.
 Manual Device: HKCT Series

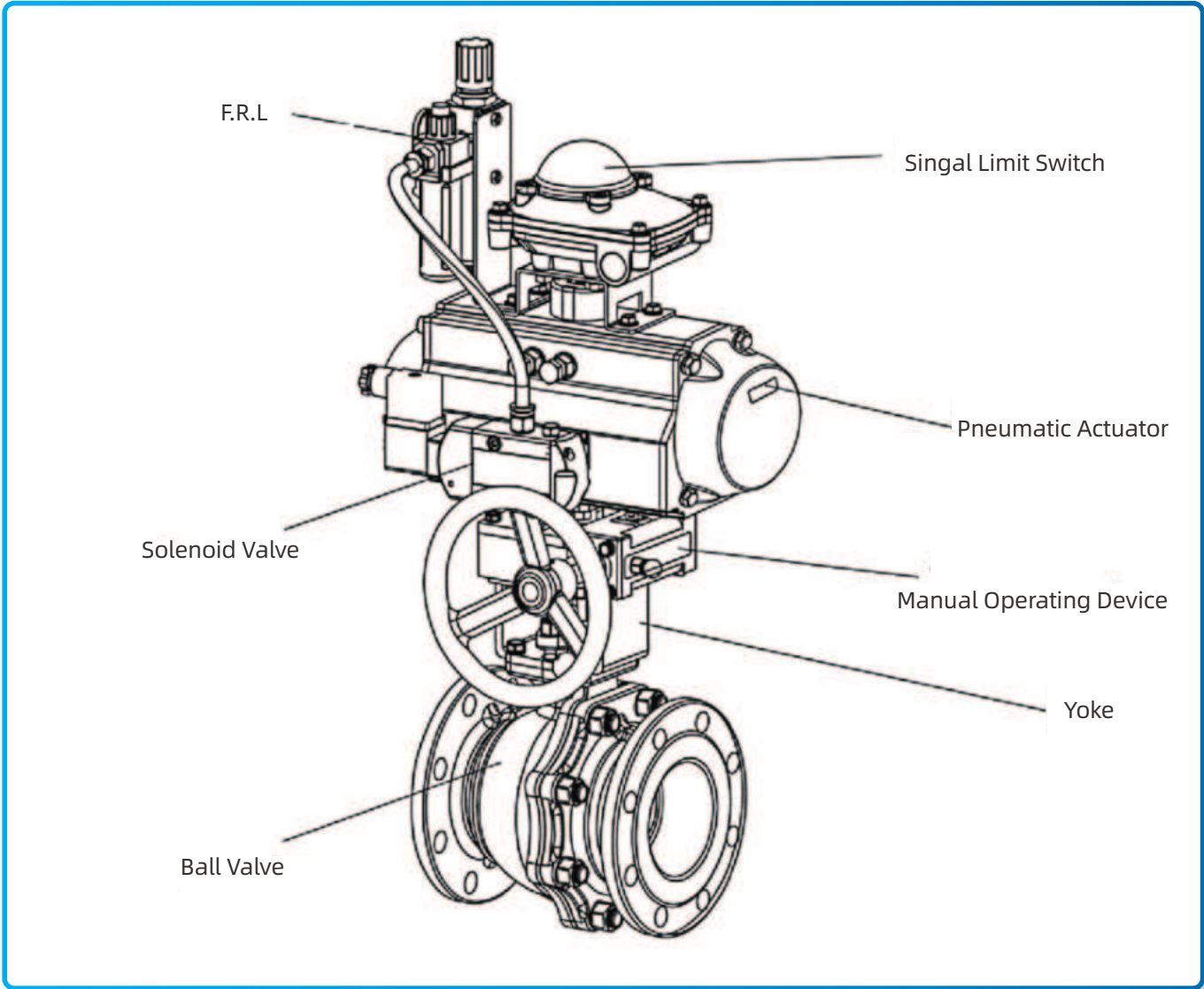

Seeking For Global Distributors



dc DELCO

Specialized Control Valve Manufacturer



DELCO VALVE CO.LTD

Phone: +86-159 8960 2972

Website: www.delcofluid.com / www.delcovalves.com / www.delcovalve.ru

E-mail: sales@delcofluid.com

Address: Building 8A#, Tiansheng Industrial Park, Wanjiang Street, Dongguan, China

