

| ZONE |  | REV | DESCRIPTION | DATE | APPROVED |
|------|--|-----|-------------|------|----------|
|      |  |     |             |      |          |

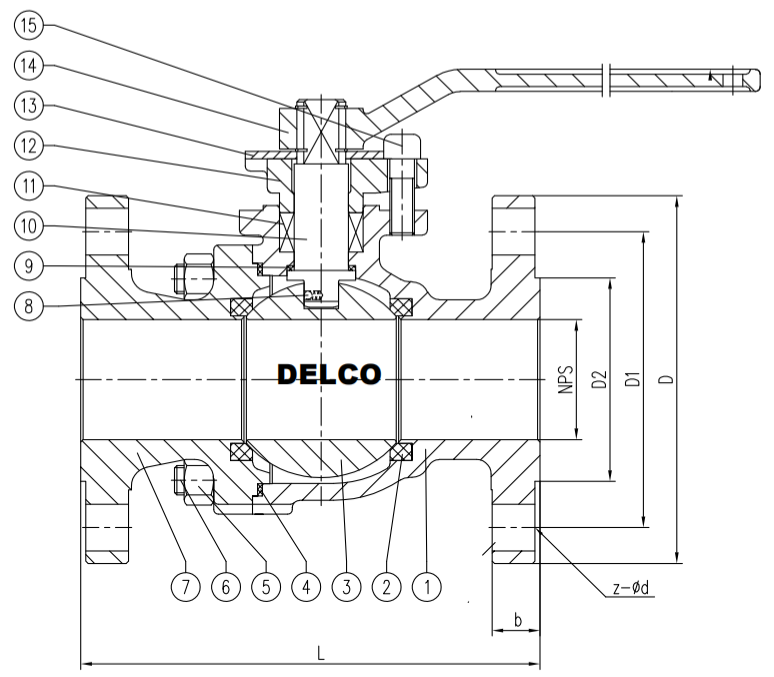

|                            |                 |
|----------------------------|-----------------|
| Design And Manufacture     | JIS B2071       |
| Face To Face               | JIS B2002       |
| Flange Connction Dimension | JIS B2212/B2214 |
| Test:                      | JIS B2003       |

| No. | Name               | Material          | Note |
|-----|--------------------|-------------------|------|
| 15  | Screw              | ASTM A193 B7      |      |
| 14  | Lever              | ASTM A216 WCB     |      |
| 13  | Stopper            | ASTM A29 1025+Zn  |      |
| 12  | Packing Gland      | ASTM A216 WCB     |      |
| 11  | Packing            | Flexible Graphite |      |
| 10  | Stem               | ASTM A182 F6a     |      |
| 9   | Thrust Washer      | PTFE              |      |
| 8   | Anti-static Device | SS304             |      |
| 7   | Bonnet             | ASTM A216 WCB     |      |
| 6   | Bolts              | ASTM A193 B7      |      |
| 5   | Nuts               | ASTM A194 2H      |      |
| 4   | Gasket             | SS304+Graphite    |      |
| 3   | Ball               | ASTM A105+ENP     |      |
| 2   | Seat               | PTFE              |      |
| 1   | Body               | ASTM A216 WCB     |      |

| MEDLE | DN15  | DN20  | DN25  | DN32   | DN40   | DN50  | DN65   | DN80  | DN100 | DN125   | DN150   | DN200   | DN250  |
|-------|-------|-------|-------|--------|--------|-------|--------|-------|-------|---------|---------|---------|--------|
| G     | 1/2"  | 3/4"  | 1"    | 1-1/4" | 1-1/2" | 2"    | 2-1/2" | 3"    | 4"    | 5"      | 6"      | 8"      | 10"    |
| D3    | 15    | 20    | 25    | 30     | 40     | 50    | 65     | 80    | 100   | 125     | 150     | 200     | 250    |
| D2    | 52    | 58    | 70    | 80     | 85     | 100   | 120    | 130   | 155   | 185     | 215     | 265     | 325    |
| D1    | 70    | 75    | 90    | 100    | 105    | 120   | 140    | 150   | 175   | 210     | 240     | 290     | 355    |
| D     | 95    | 100   | 125   | 135    | 140    | 155   | 175    | 185   | 210   | 250     | 280     | 330     | 400    |
| L     | 108   | 117   | 127   | 140    | 165    | 178   | 190    | 203   | 229   | 330/356 | 340/394 | 450/457 | 533    |
| b     | 12    | 14    | 14    | 16     | 16     | 16    | 18     | 18    | 18    | 20      | 22      | 22      | 24     |
| z-ød  | 4-φ15 | 4-φ15 | 4-φ19 | 4-φ19  | 4-φ19  | 4-φ19 | 4-φ19  | 8-φ19 | 8-φ19 | 8-φ23   | 8-φ23   | 12-φ23  | 12-φ25 |

|  |  |              |                 |
|--|--|--------------|-----------------|
| TOLERANCE<br>UNLESS OTHERWISE SPECIFIED<br>DECIMALS: .0 ± .1<br>.00 ± .01<br>.000 ± .005<br>ANGLES: MACH. ±1°00"<br>FORMED ±2°<br>FRACTIONS: ± 1/16" | <b>DELCO VALVE CO.,LTD</b>                         |              |                 |
|  | TITLE<br><b>Stainless Steel Ball valve JIS 10K</b> |              |                 |
| APPROVED BY<br>BOND  | FSCM:  | DWG NO.      | REV<br><b>A</b> |
| CHECKED BY<br>JULIA  | SIZE<br>mm   | SCALE<br>1:1 | SHEET<br>1 of 1 |
| DRAWING BY<br>C L  | SHEET 1 OF 1                                       |              |                 |