

Explosion-Proof Electric V-Port Ball Valve

INSTRUCTION MANUAL



dc DELCO

Specialized Control Valve Manufacturer



Introduction

Explosion proof electric flange V-shaped ball valve can be controlled by inputting (4-20mA DC or 1-5VDC) signals and single-phase power supply to adjust parameters such as pressure, flow rate, temperature, and liquid level. There is a V-shaped cut on the valve core, which generates shear force when rotating relative to the hard sealed valve seat, which can cut off the fibers and prevent them from getting stuck. It has the characteristics of circulation ability, high adjustment accuracy, large adjustable ratio, good sealing performance, and light weight. Suitable for most occasions except for small caliber, angular, and three-way connections, it can replace imported products.

Actuator Technical Parameters

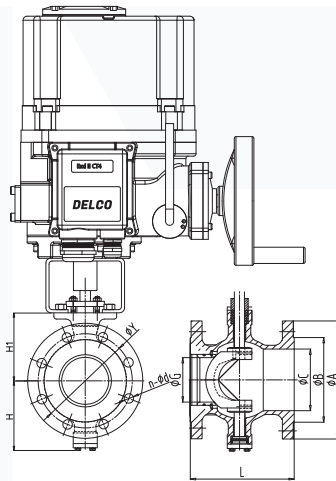

ON-OFF Type	Feedback: Active Contact Signal, Passive Contact Signal, Resistance, 4-20mA
Regulation Type	Input & Output Signal: DC 4-20mA, DC 0-10V, DC 1-5V
Intelligent ON/OFF Type	The Local, Remote Control ON/OFF Type and MODBUS, PROFUBUS Field Bus
Intelligent Regulation Type	The Local, Remote Control Regulation Type and MODBUS, PROFUBUS Field Bus
Optional Voltage	AC380V AC220V DC24V, Special Voltage Can Be Customized

Technical Parameters

Nominal Size	DN15~DN300
Body Material	Carbon Steel(WCB), Stainless Steel(CF8, CF8M)
Connection Type	Flange
Pressure Rating	PN1.6PN 6.3MPa
Structure Type	Floating Ball Core, 3Way-T Type, 3Way-L Type
Seat Material	PTFE: -30°C~180°C
Core Material	SS304, SS316, SS316L
Stem Material	SS304, SS316, SS316L
Applicable Medium	Water, Liquids, Gas, Oil, Powder, Steam, Acid-Base Corrosive Medium

Main Outline and Connecting 1.6 MPa

MEDLE	DN25	DN32	DN40	DN50	DN65	DN80	DN100	DN125	DN150	DN200
Inch	1"	1-1/4"	1-1/2"	2"	2-1/2"	3"	4"	5"	6"	8"
A	115	140	150	165	185	200	220	250	285	340
B	65	76	84	99	118	132	156	184	211	266
C	38	45	50	62	73	90	115	134	164	206
G	20	25	32	40	55	62	80	100	125	155
Y	85	100	110	125	145	160	180	210	240	295
n-Φd	4-Φ14	4-Φ18	4-Φ18	4-Φ18	8-Φ18	8-Φ18	8-Φ18	8-Φ18	8-Φ22	12-Φ22
L	102	102	114	124	145	165	194	194	229	243
H	81	86	90	93	108	123	138	128	170	200
H1	178	183	185	195	210	223	235	250	270	320

Main Technical Parameters, Specifications

MODEL	QT-10	QT-15	QT-20	QT-30	QT-40	QT-50	QT-60	QT-80	QT-90	QT-100	QT-200
Max Output Torque	100	150	200	300	350	400	500	600	800	1000	2000
90°Action Time	18/22	18/22	21/25	21/25	26/31	26/31	26/31	26/31	31/37	31/37	93/112
Motor Power	25	40	40	60	90	90	120	120	180	200	200
Rated Current	AC220V	0.55	0.9	0.9	1.0	1.2	1.2	1.9	1.9	2.4	2.6
	AC380V	≤0.1	≤0.1	≤0.1	0.3	0.55	0.55	0.6	0.6	1.2	1.4
Handwheel Revolution	10	10	11	11	14	14	14	18	18	18	50

Standard Specification

Housing	Waterproof Level IP67,NEMA 4 and 6	
Voltage Options	Standard:220VAC Single-Phase 50/60Hz,±10% Optional: 380 AC Three-Phase, 50/60Hz, ±10%	
Motor	Squirrel-Cage Asynchronous Motor	
Limit Switch	ON/OFF,Each of the 1 SPDT AC250V/16A	
Auxiliary Limit Switch	ON/OFF,Each of the 1 SPDT AC250V/16A	
Torque Switch	ON/OFF,Each of the 1 SPDT AC250V/16A	QT-010 Excluded
Itineraries	90°±10°	0~270° Optional
Stall Protection/ Operating Temperature	Built-inoverheating Protection, Open 115°C±5°C/Close 97°C±5°C	
Indicator	Continuousposition Indicator Scale	
Manual Operation	Mechanical Clutch Mechanism, With Handwheel Operation	
Self-Locking Device	Wonn Gear, Self-Locking Provided for the Worm Mechanism	
Mechanical Limit	Two External Adjusting Bolts	
Desiccator	25W (110/220VAC)	
Connection Hole	2 PCS PE 3/4"	
Ambient Temperature	-20°C~+70°C	
Lubrication	Aluminium-Base Grease (EP Type)	
Materials	Steel/Aluminum Alloy/Aluminum Bronze/Polycarbonate	
Ambient Humidity	Maximum 90% RHnon-Condensing	
Aseismic Performance	X Y Z 10g, 0.2-34 Hz, Minutes	
External Coating	Dry Powder/Epoxy polyester, With a Superior Anti-Corrosion Function	

Structure Composition

The Electric Actuator Mainly Consists of the Following Parts:

- »Housing part: including housing and base;
- »Driving part: powered by a high- performance fullyenclosed squirrel- cage motor;
- »Transmission mechanism: double worm gear and clutch;
- »Proportional control part: isolated from the mechanical part toimprove reliability;
- »Torque switch and limit switch part; Opening detection and feedback part.

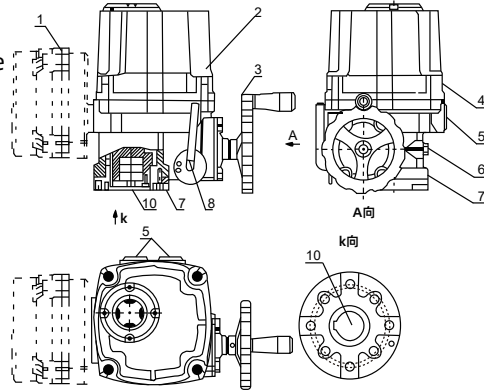

01	Control Room
02	Enclosure
03	Handwheel
04	Housing
05	Cable Connection Plyg
06	Mechanical Limit Screw
07	Connecting Flange
08	Clutch Handle
09	Window
10	Output Shaft

Outline Dimension Drawing Of Actuator

QT-10/15

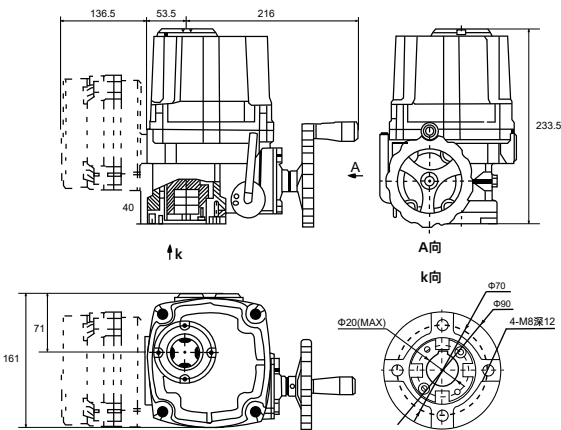

QT-20

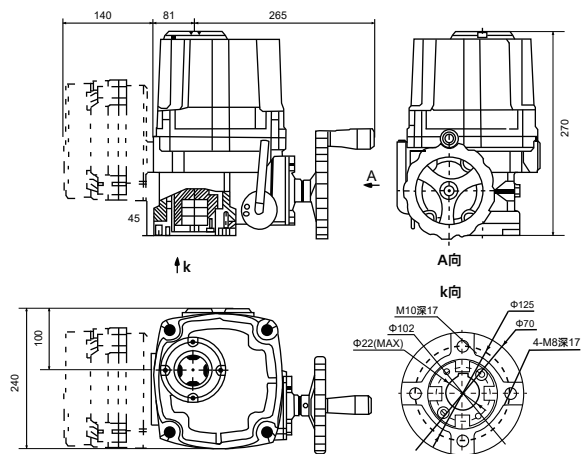

QT-50/60

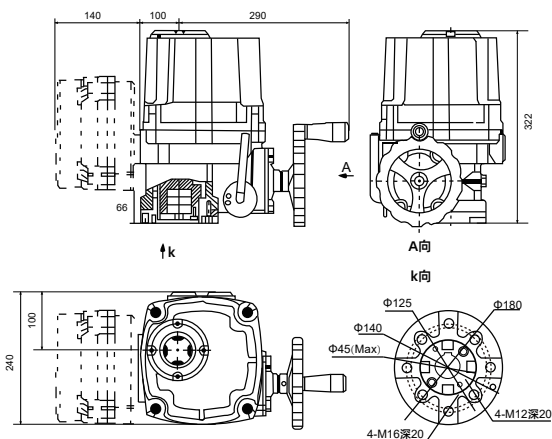

QT-100/200

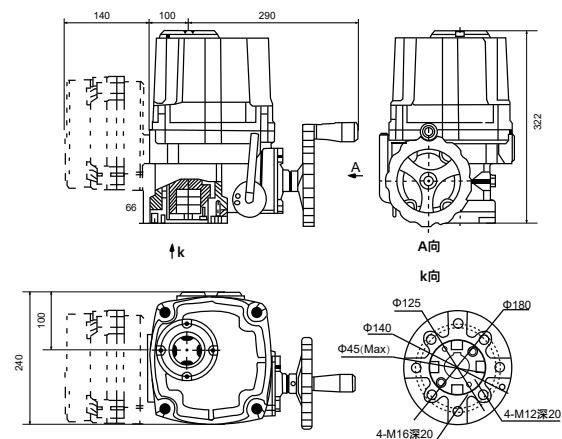

Wiring Diagram

220V Wiring Diagram Of Switch Type

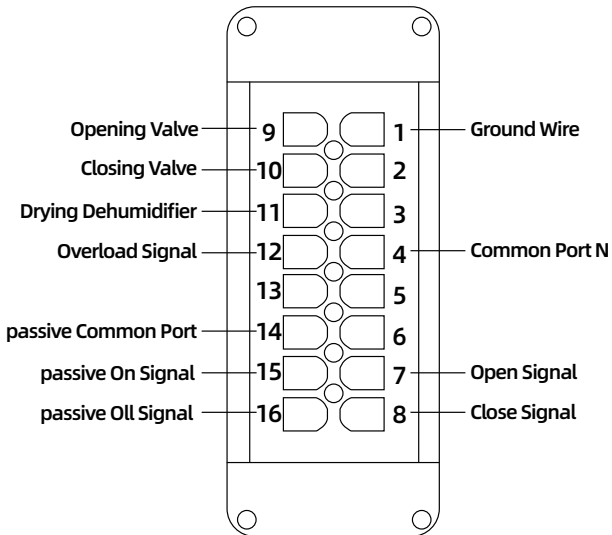

380V Wiring Diagram Of Switch Type

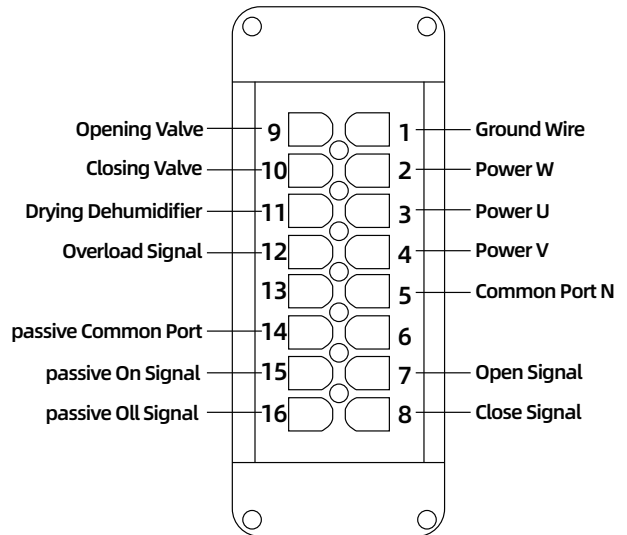

Wiring Diagram Of Intelligent Adjustable Type

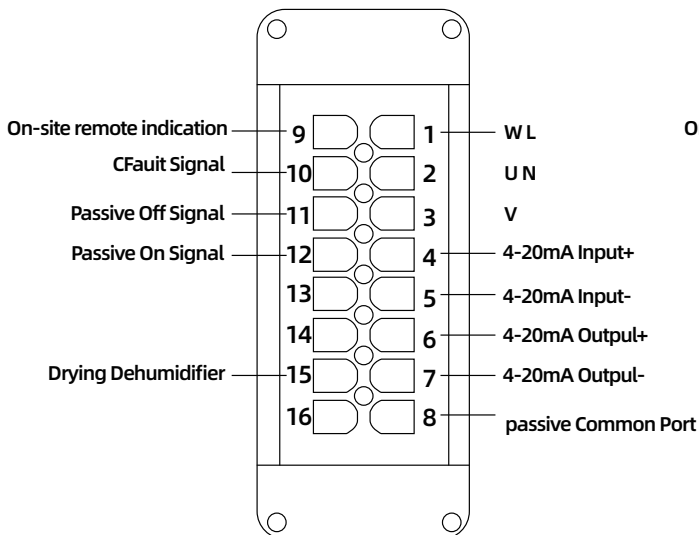

Wiring Diagram Of Intelligent Switch Type

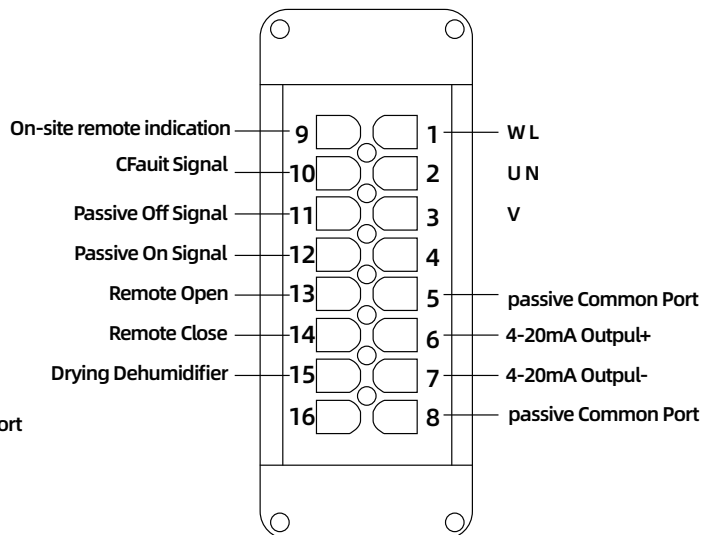

Seeking For Global Distributors



dc DELCO

Specialized Control Valve Manufacturer



DELCO VALVE CO.LTD

Phone: +86-159 8960 2972

Website: www.delcofluid.com / www.delcovalves.com / www.delcovalve.ru

E-mail: sales@delcofluid.com

Address: Building 8A#, Tiansheng Industrial Park, Wanjiang Street, Dongguan, China

