

# TECHNICAL DATA

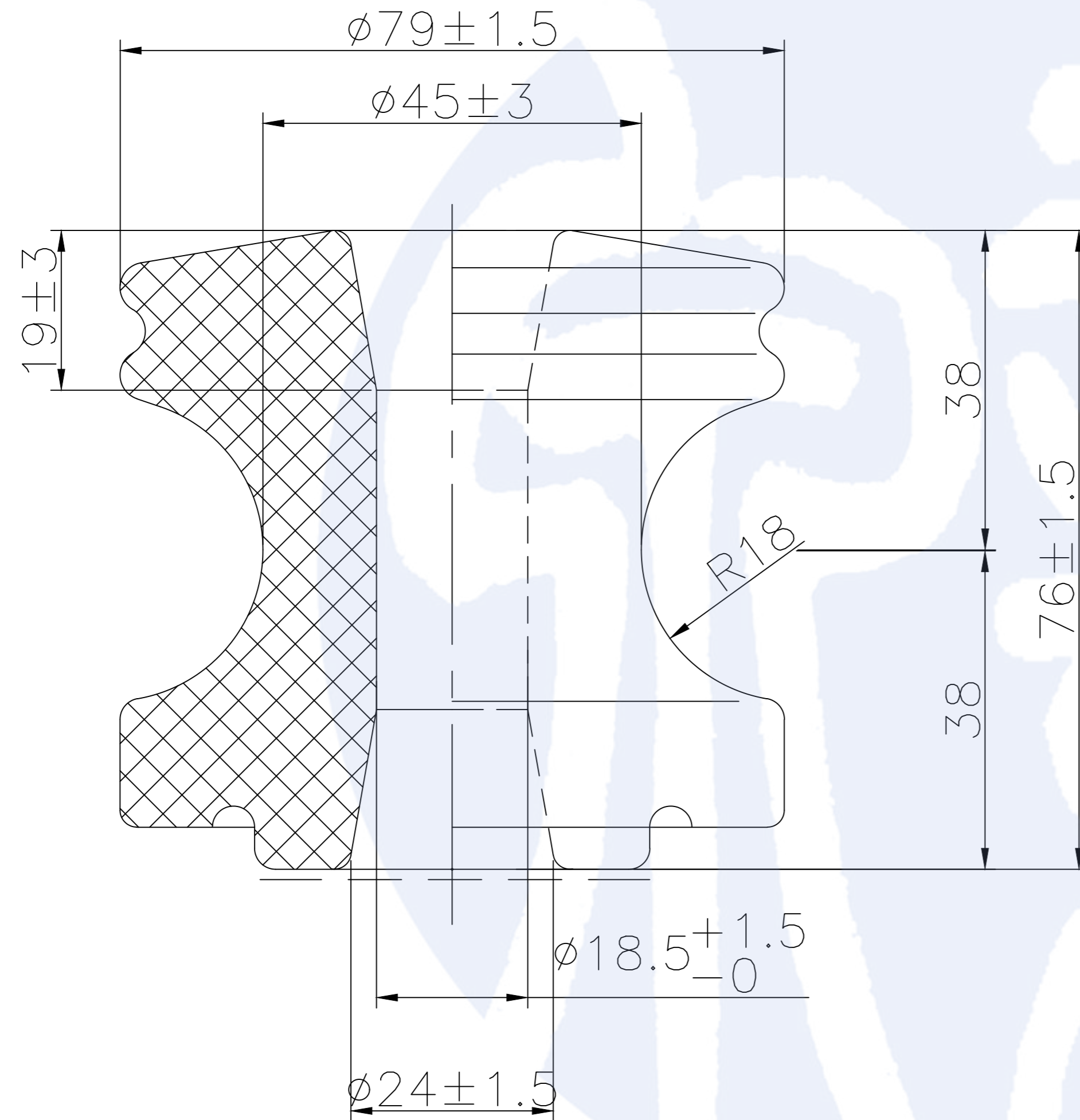

Type

ANSI 53-2

Standard Applied

ANSI C29.3

Main Dimensions

D:

79mm

H:

76mm

Mechanical Failing Load

13.3kN

Low frequency dry flashover voltage

25kV

Low frequency wet flashover voltage, vertical

12kV

Low frequency wet flashover voltage, horizontal

15kV

MATERIAL: PORCELAIN



**Jiangxi QOCI Electric CO.,LTD.**

[www.quanxinelectric.com](http://www.quanxinelectric.com)

Design	Standard	Marker	
Num	Sigh		
Audit	Date	Weight	0.5KG
Notes	Approved	Scale	1:1



**QOCI**

Spool Type  
Porcelain Insulator

**ANSI 53-2**