

BTN350/450/550/650GC 渐进式 / 比例调节燃气燃烧器

BTN350/450/550/650GC

Progressive/Modulation Gas Burner

功率 Power (kW)	型号 Model	订货编号 Article No.	电源 Power supply	电机功率 Motor power (kW)	包装尺寸 package size (L*W*H/mm)	重量 weight (kg)
1300~3900	BTN350GC	203 22 512	380V 50Hz	7.5	1950x1120x1100	250
2000~4900	BTN450GC	203 22 513	380V 50Hz	9.2	1950x1120x1100	250
2200~5250	BTN550GC	203 22 514	380V 50Hz	12	1950x1120x1100	250
2400~6300	BTN650GC	203 22 515	380V 50Hz	15	1950x1120x1100	280

外观尺寸图

Overall dimensions

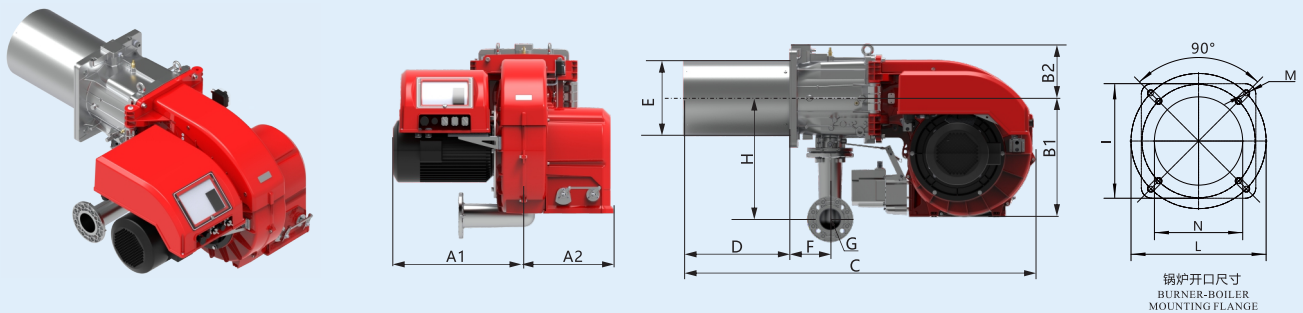

型号 model	A1	A2	B1	B2	C	D	E	F	G	H	I	L	M	N
	mm	mm	mm	mm	mm	mm	Φmm	mm	mm	mm	mm	Φmm	M	Φmm
BTN350GC	556	400	519	239	1594	519	306	178	DN65	528	400	452	4-M16	350
BTN450GC	556	400	519	239	1594	519	306	178	DN65	528	400	452	4-M16	350
BTN550GC	583	400	519	239	1594	519	306	178	DN65	528	400	452	4-M16	350
BTN650GC	583	400	519	239	1575	500	330	178	DN65	528	400	452	4-M16	350

备选功能

Alternative function

加长的燃烧筒，可定制60Hz
Longer blast tube and 60Hz motor is customized.

使用LPG燃气时，需在燃烧头上安装该特殊组件
When using LPG gas, this special component is installed on the burner

阀组-与锅炉配套的组件
Valve block - Component for boiler

比例调节功能

Proportional control function

另外订购比例仪RWF40或DC1020与调节组件，燃烧器即可实现比例调节运行。

In addition, order the proportioner RWF40 or DC1020 and the regulating assembly, and the burner can be proportionally regulated.

备注

remark

- 1)配有空气关闭装置
1)It is with air closure device.
- ***)阀组进口允许的最大燃气压力。
***)Allowed Max.gas pressure in valve set input.

曲线图

curve graph

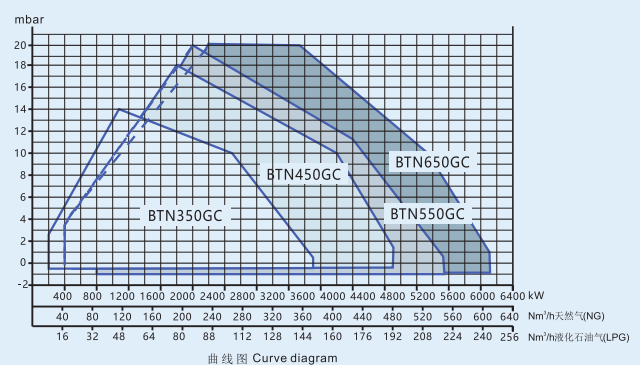

BTN350/450/550/650GC 渐进式 / 比例调节燃气燃烧器

BTN350/450/550/650GC Progressive/Modulation Gas Burner

锅炉燃烧器功率(kW)

Burner Output (kW)

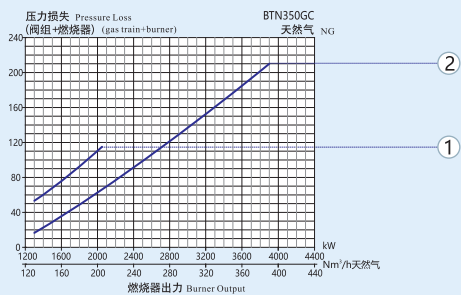

BTN350GC

天然气 natural gas

曲线 (型号) Curve (model)	阀组编号 Valve group number	检漏 Leakage control	最大压力** Maximum pressure value (mbar)	图号 figure number
① QF-MVD220/5+MVDLE220/5-DN65	222 25 454	-	200	QF2
② QF-DMV-D5065/11-DN65	222 25 128	-	500	QF1
② QF-DMV-D5065/11-LDU-DN65	222 25 145	-	560	QF1
① QF-MB-DLE420 B01 S20-DN65	222 25 665	-	700	QF4
② QF-VGD40.065-LDU-DN65	222 25 247	GW150A5	700	QF4

锅炉燃烧器功率(kW)

Burner Output (kW)

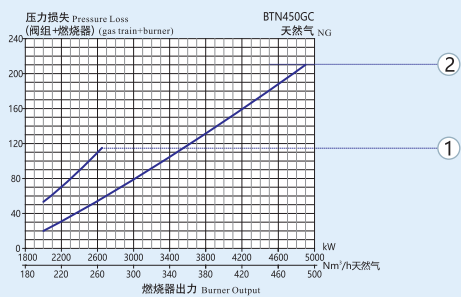

BTN450GC

天然气 natural gas

曲线 (型号) Curve (model)	阀组编号 Valve group number	检漏 Leakage control	最大压力** Maximum pressure value (mbar)	图号 figure number
① QF-MVD220/5+MVDLE220/5-DN65	222 25 454	-	200	QF2
② QF-DMV-D5065/11-DN65	222 25 128	-	500	QF1
② QF-DMV-D5065/11-LDU-DN65	222 25 145	-	560	QF1
① QF-MB-DLE420 B01 S20-DN65	222 25 665	-	700	QF4
② QF-VGD40.065-LDU-DN65	222 25 247	GW150A5	700	QF4

锅炉燃烧器功率(kW)

Burner Output (kW)

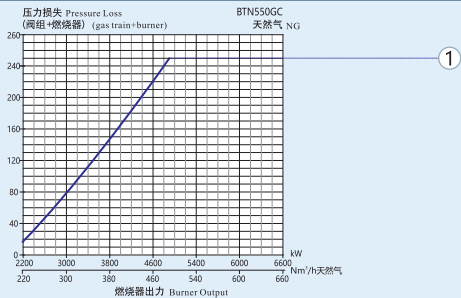

BTN550GC

天然气 natural gas

曲线 (型号) Curve (model)	阀组编号 Valve group number	检漏 Leakage control	最大压力** Maximum pressure value (mbar)	图号 figure number
① QF-DMV-D5065/11-DN65	222 25 128	-	500	QF1
① QF-DMV-D5065/11-LDU-DN65	222 25 145	GW150A5	500	QF1
① QF-VGD40.065-DN65	222 25 233	-	700	QF4
① QF-VGD40.065-LDU-DN65	222 25 247	GW150A5	700	QF4

锅炉燃烧器功率(kW)

Burner Output (kW)

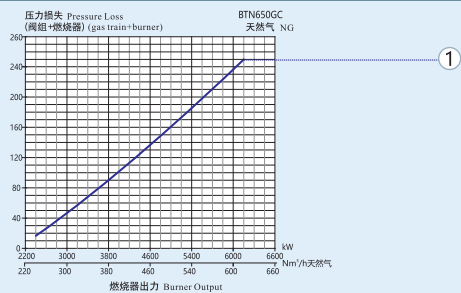

BTN650GC

天然气 natural gas

曲线 (型号) Curve (model)	阀组编号 Valve group number	检漏 Leakage control	最大压力** Maximum pressure value (mbar)	图号 figure number
① QF-DMV-D5065/11-DN65	222 25 128	-	500	QF1
① QF-DMV-D5065/11-LDU-DN65	222 25 145	GW150A5	500	QF1
① QF-VGD40.065-DN65	222 25 233	-	700	QF4
① QF-VGD40.065-LDU-DN65	222 25 247	GW150A5	700	QF4