

Version

A

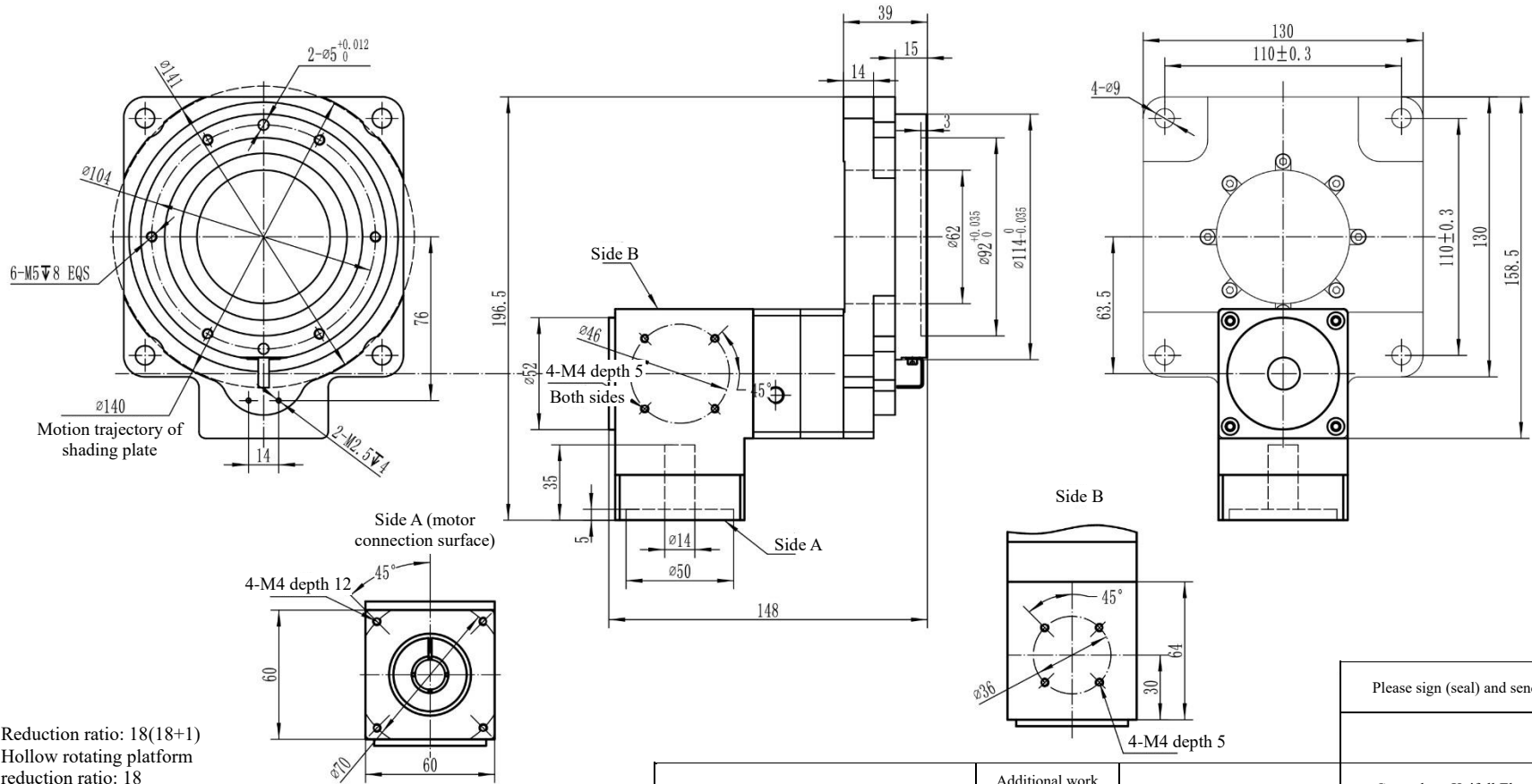

Reduction ratio: 18(18+1)
 Hollow rotating platform
 reduction ratio: 18
 Corner reduction ratio: 1
 Permissible output torque: 20N.m
 Permissible output speed:
 200RPM
 Permissible thrust load: 250kgf
 Positioning accuracy: ≤ 8arc min
 Platform end face runout: 0.01m

Please sign (seal) and send back

	Additional work	Hollow rotating platform			Guangdong Kaifull Electronics Technology Co., Ltd.
		Angle of view			YKW130R-18V1
		Stage mark	Weight	Scale	
Material name	Processing method			1:1.9	
Non-standard information bar		Page of			

*Continuous service life: 10000h