

Examples of communication

Example of communication for the BN-8032-L module

1 Topology

ProfiNet Master Communication topology diagram

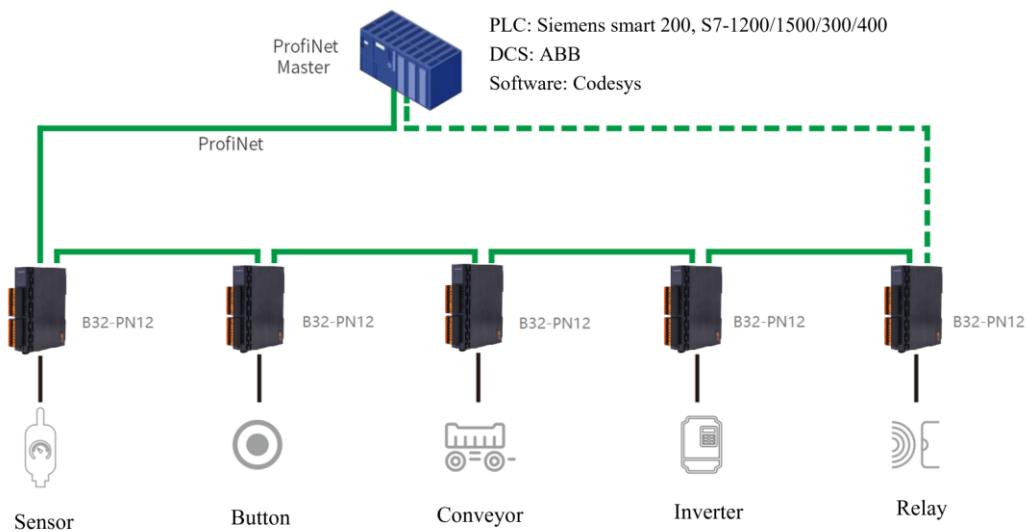

2 Example of communication between the Siemens S7-300 (STEP 7) and the module

1. Power on the module and S7-315 2 PN/DP, and connect the network cable to the PC. Open the Siemens STEP 7 software. New project "PN-IO". Insert New Object – SIMATIC 300 Site – Double-click Hardware to open the hardware configuration screen. Click "Options" - "Install GSD File", "Browse" in the pop-up interface to find the location of the GSD file of BN-8032-L, select and click "Install".

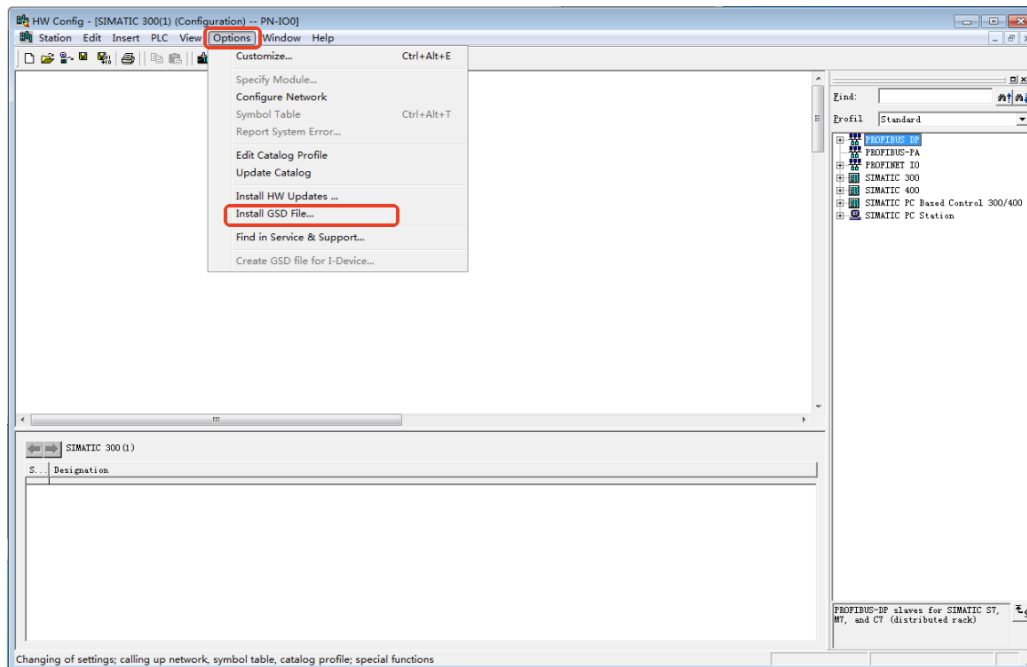
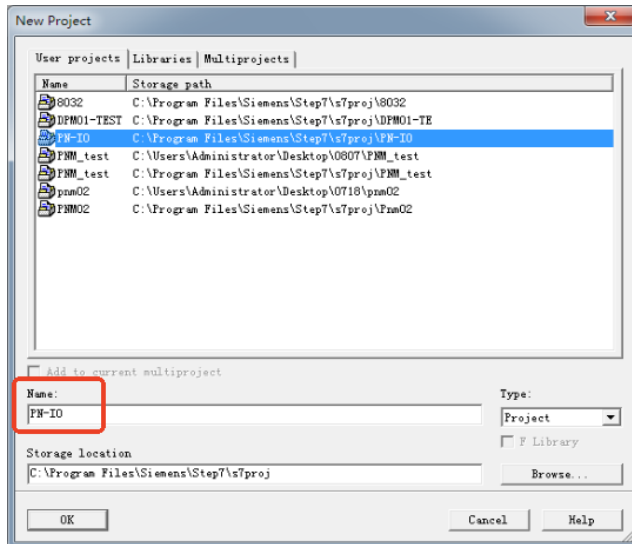

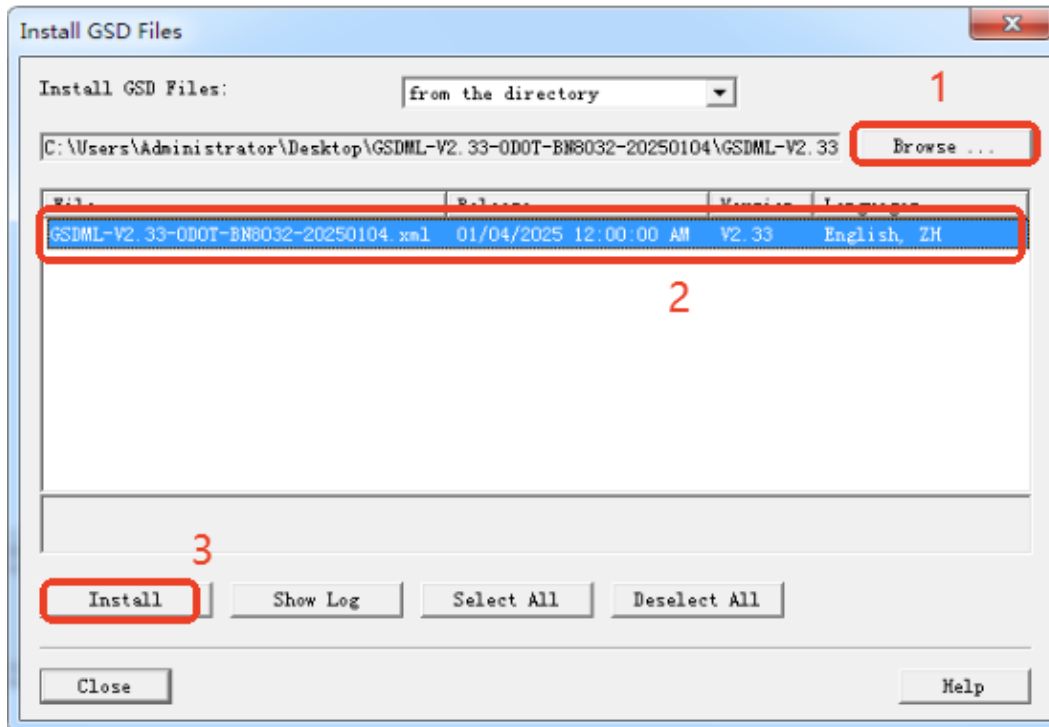

2. After the installation is completed, it can find the BN-8032-L in the Profinet IO drop-down menu on the right side of the directory.

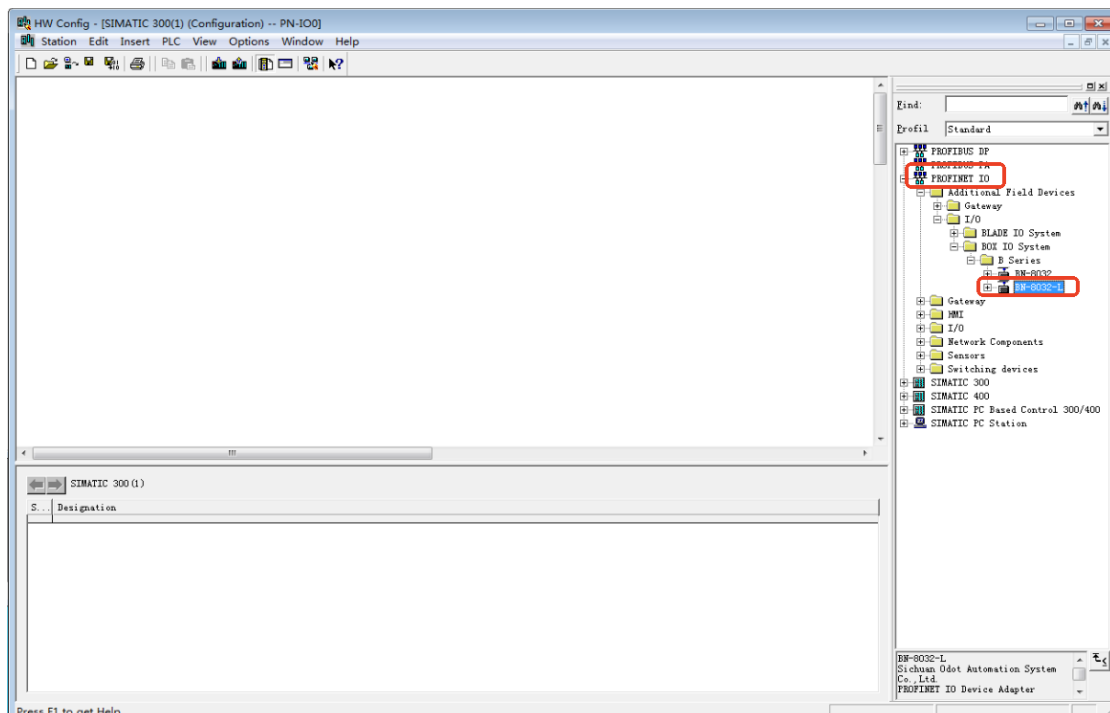

3. Drag the backplate "rail" - drag "S7-315 2 PN/DP V3.1" to the left, configure the network port parameters, IP address: 192.168.1.16. Click "New", "OK", "OK".

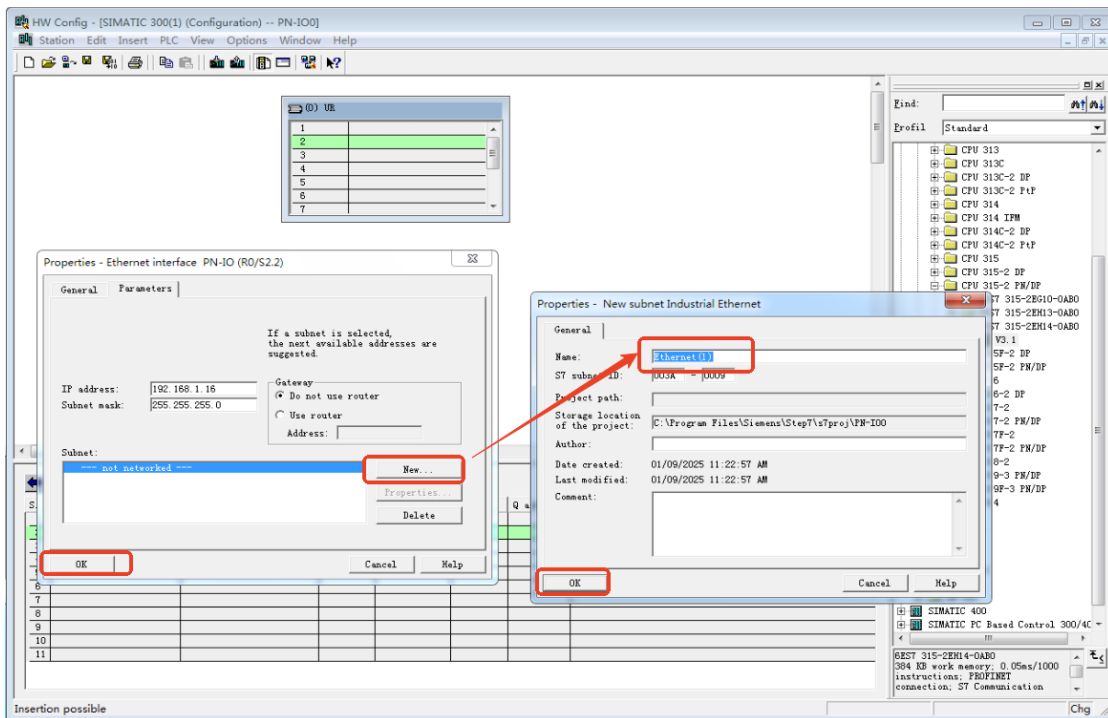
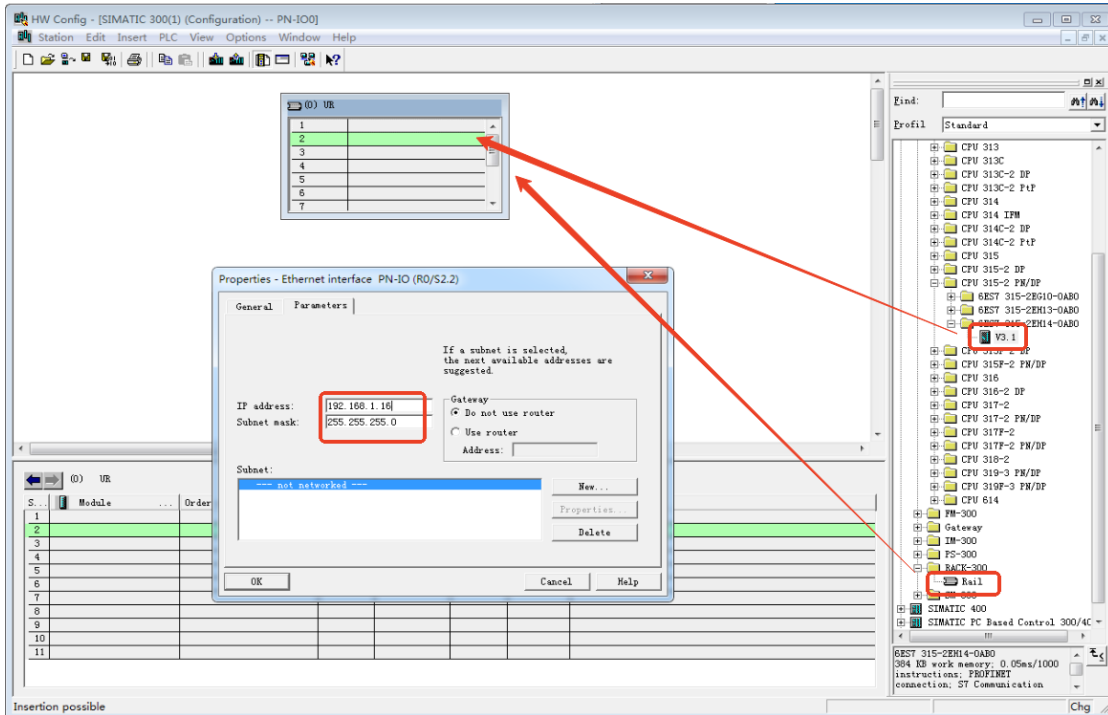

4. Drag and drop the BN-8032-L from the hardware catalog to the Profinet-IO-System bus system. Manually add an extended I/O module based on the model of the I/O module attached to the right side of the module (or upload the I/O module based on the IO Config software and manually add an extended I/O module).

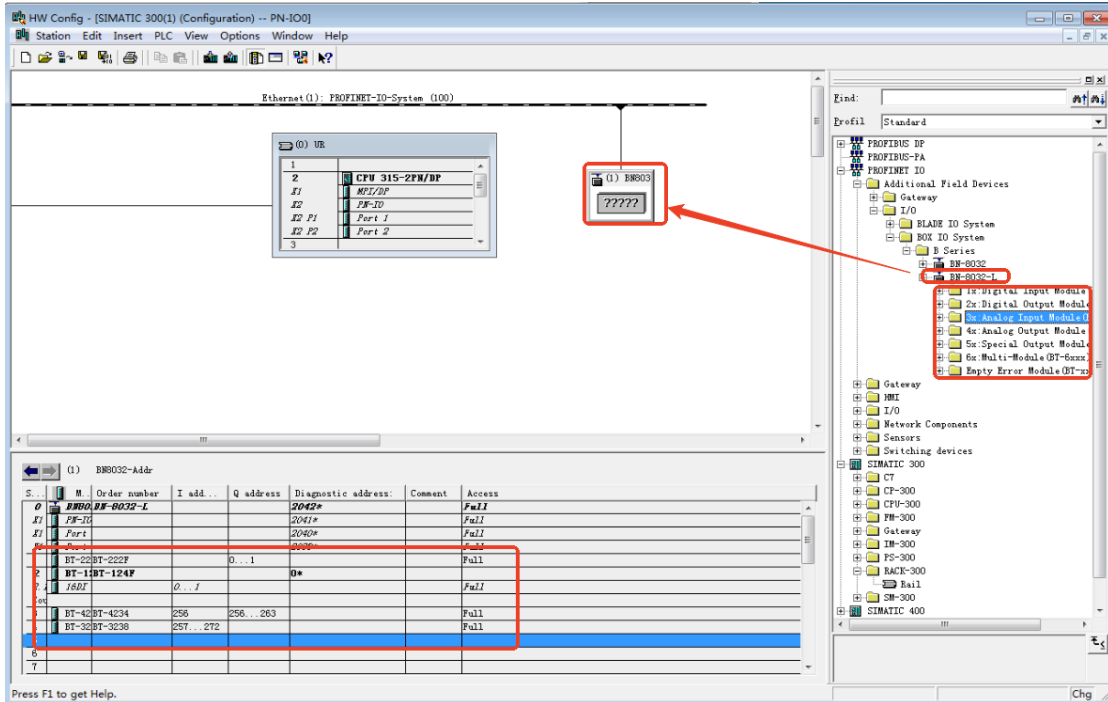

5. Double-click BN-8032-L, change the device name to BN8032-Addr on the pop-up page, click Ethernet, and manually assign the IP address: 192.168.1.17. Click Confirm.

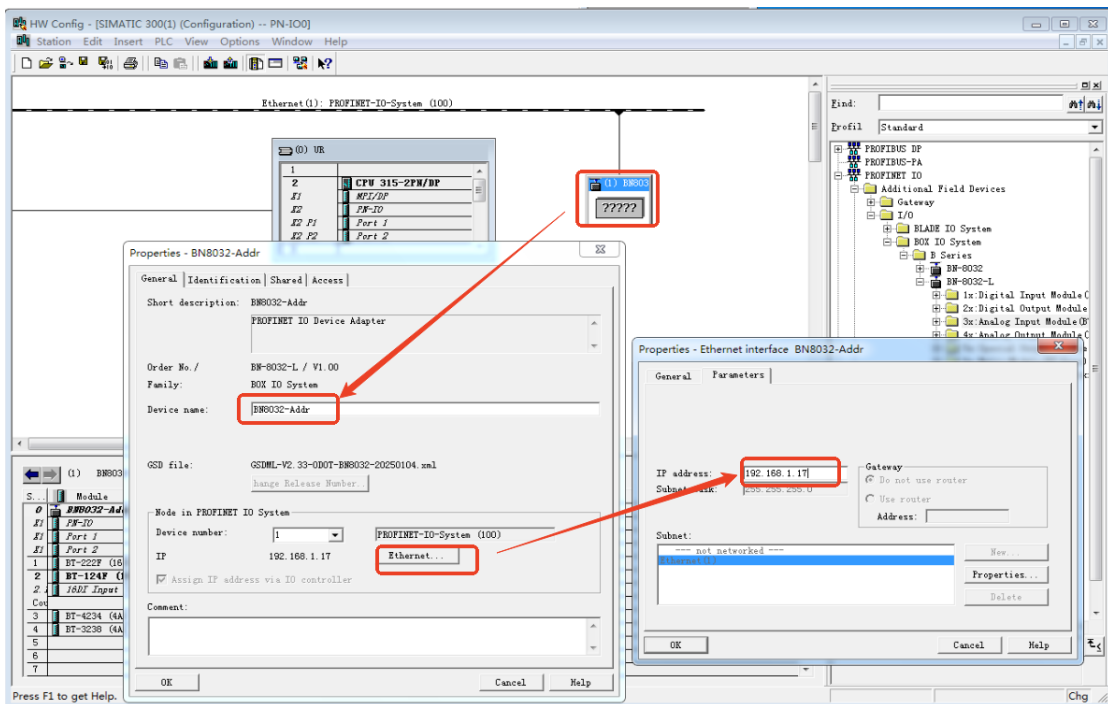

6. Double-click BN8032-Addr in slot 0 to view and modify the module parameters.

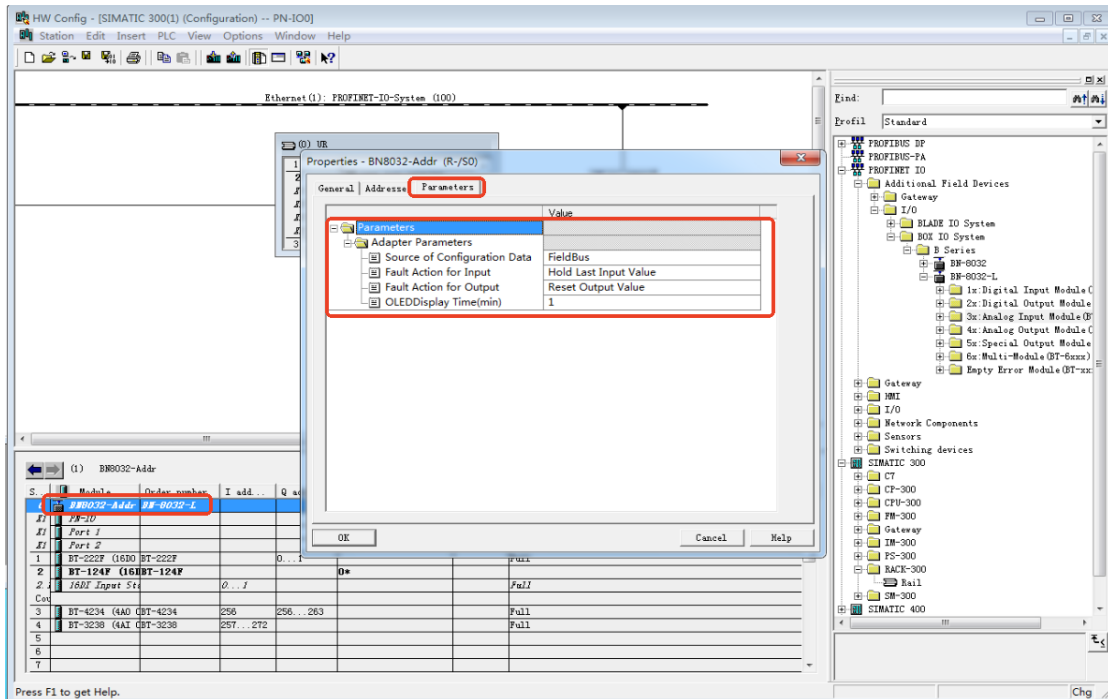

6. Double-click the extended IO modules BT-124F and BT-222F to modify the parameters according to the actual needs of customers, and the parameter definition can refer to the extended IO modules manual.

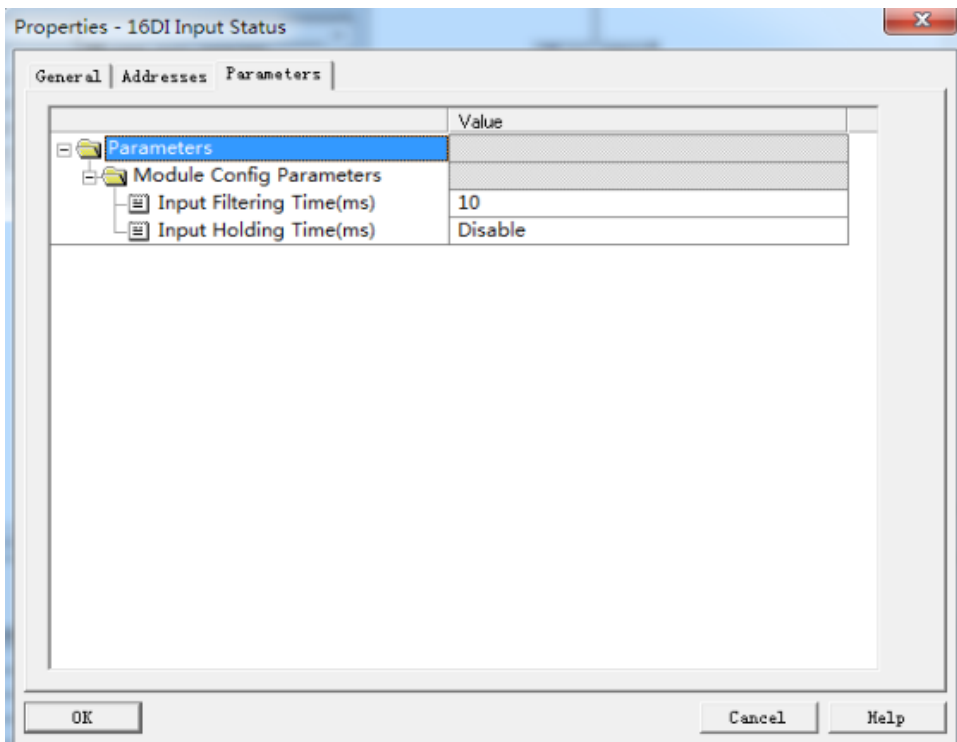

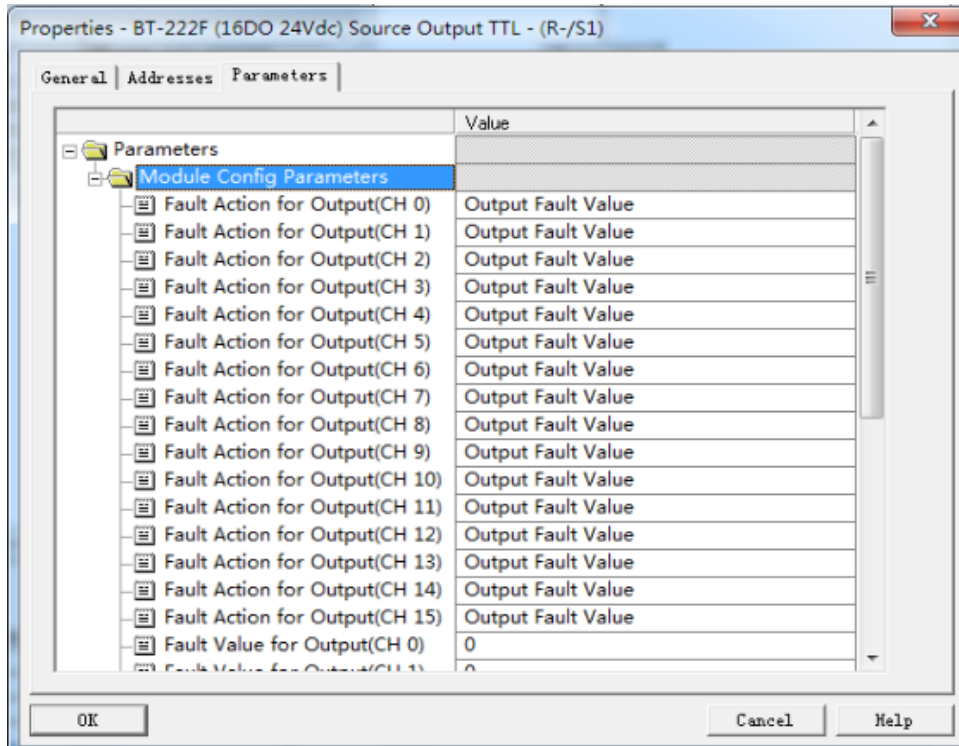

7. Save, compile and download after the configuration is completed. It can right-click to monitor the input and output module online, and the following figure shows the monitoring interface of the BT-124F input module.

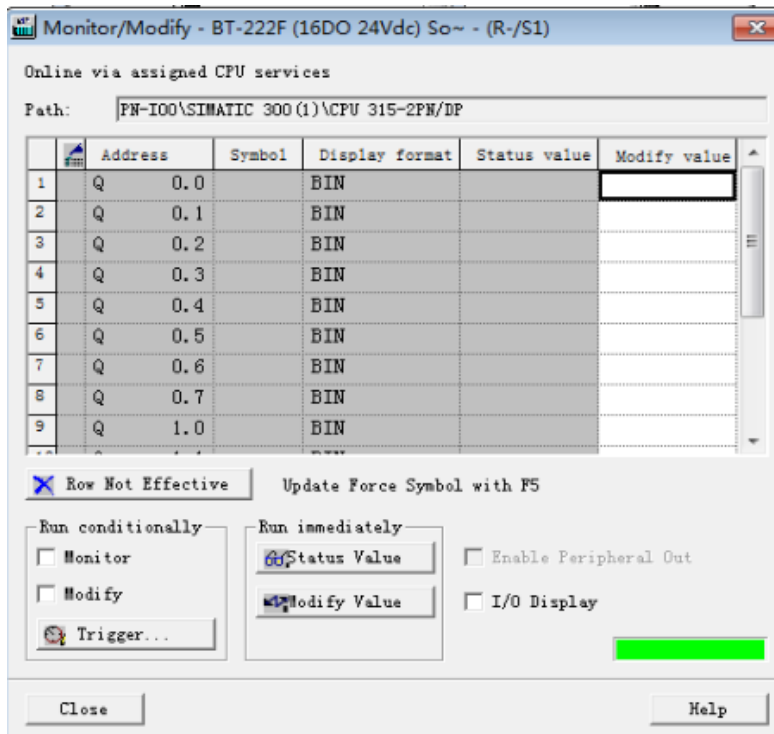

3 Example of communication between S7-200SMART (STEP 7-MicroWIN SMART) and module

1. Power on the module and S7-200SMART, and connect the network port to the PC.

Open the Siemens STEP 7-MicroWIN SMART software. Click GSDML

Management, in the pop-up window, click Browse to find the GSD file of BN-8032 and click Open to complete the installation of the GSD file.

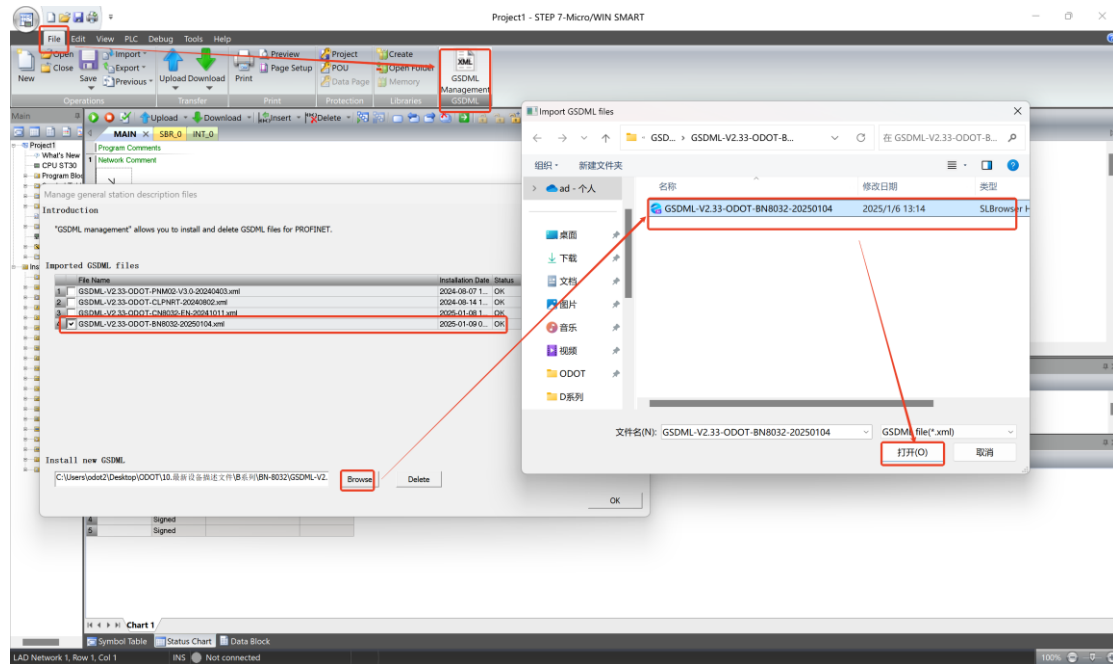

Click on Tools files, click on Find PROFINET Device, click on Find Device, find Module, and the name of the module device is bn8032-1. (The name of the device needs to be the same as this name when configuring.)

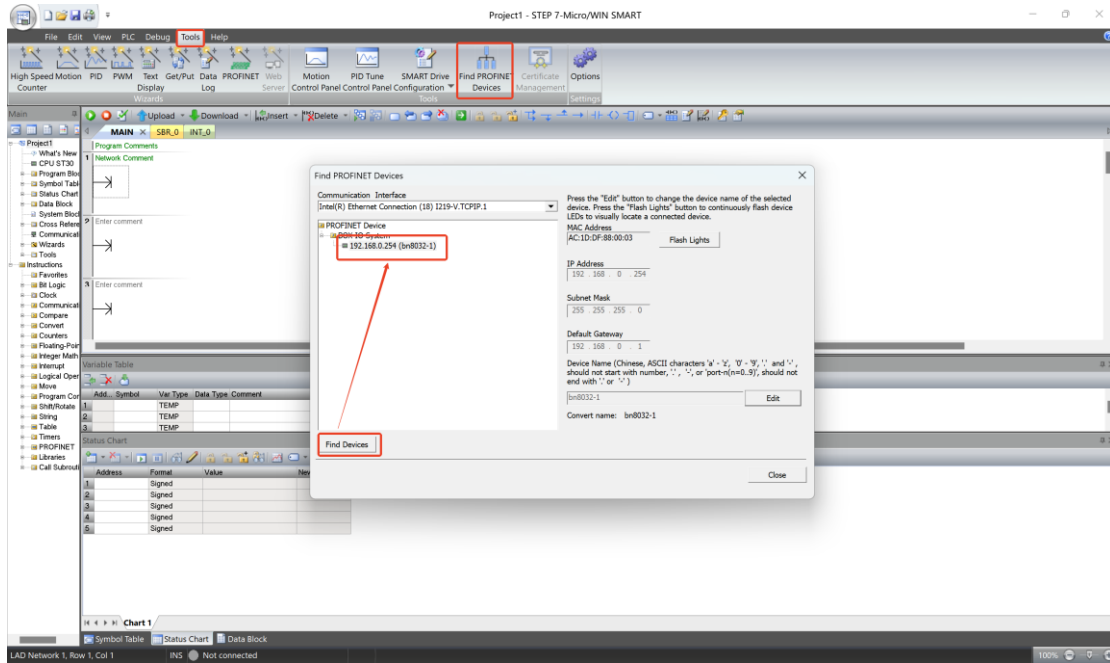

Click on Tools, click on PROFINET. Select the controller, modify the IP address of the PLC, and click Next.

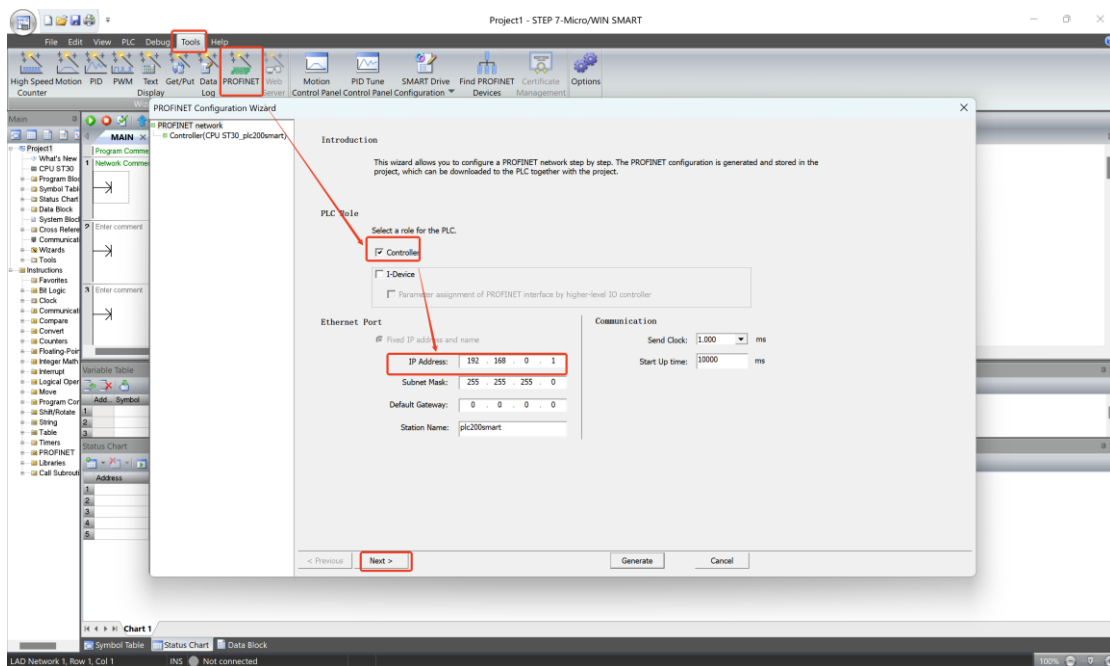

Find BN-8032-L in the hardware directory, add it to the device list, change the device name to BN8032-1 (key communication parameters), and assign the IP address of to module 192.168.0.10. Click Next when it's done.

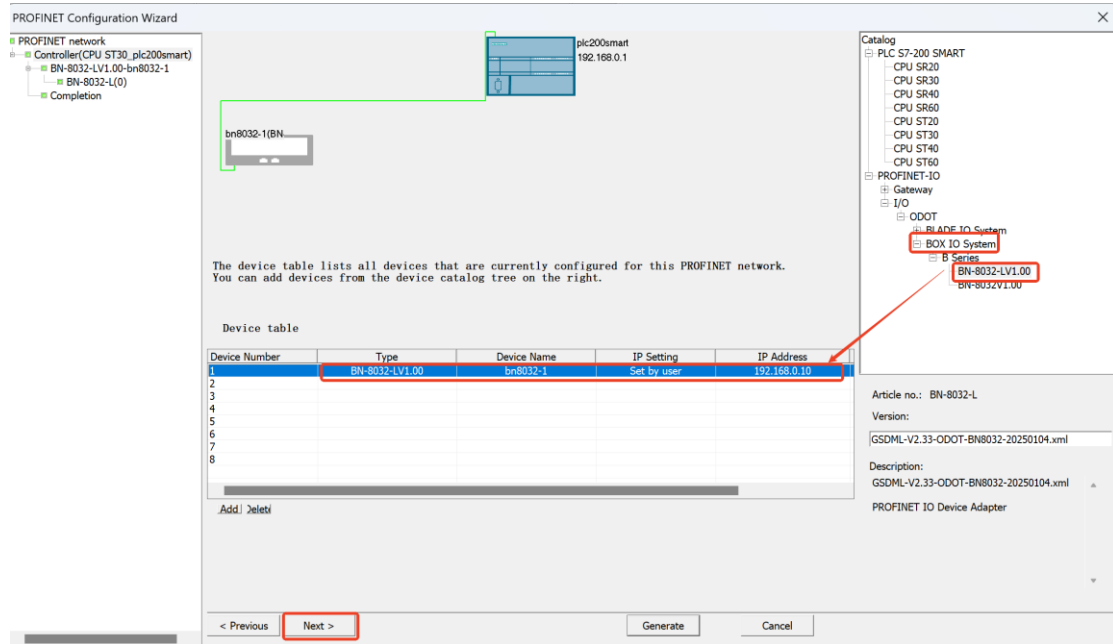

Configure the IO modules according to the model of the IO modules hung on the back of BN-8032-L. Click Generate.

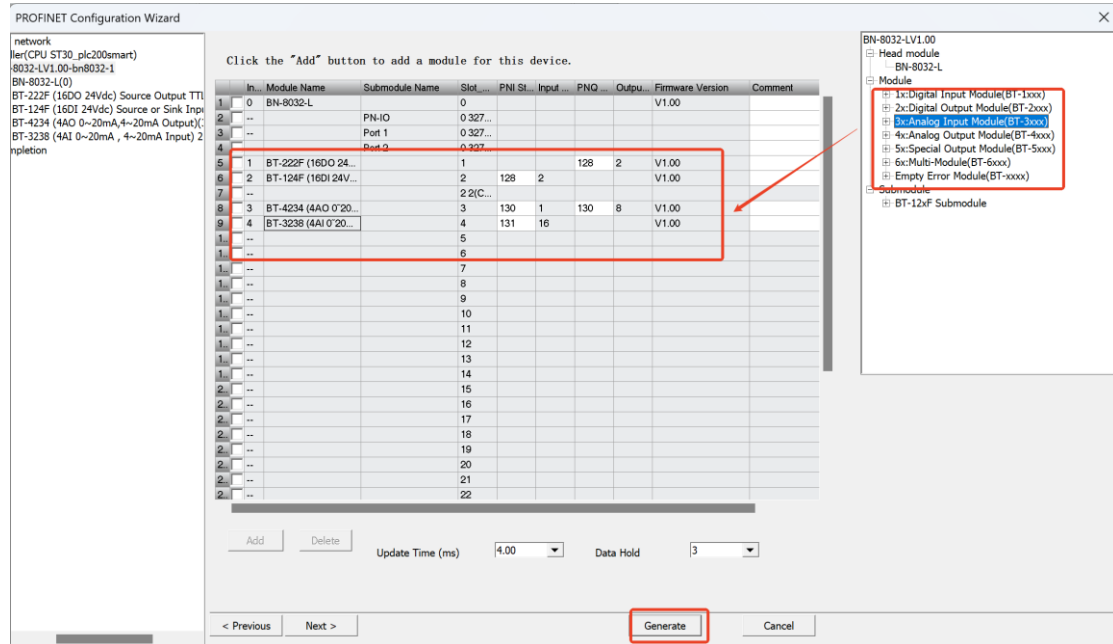

BT-222F corresponding address is QW128, BT-124F corresponding address is IW128, BT-4234 corresponding address is QW130~QW136, BT-3238 corresponding address is IW131~IW145, click to generate. Click Download, look for the CPU in the pop-up window, click OK, and click Download.

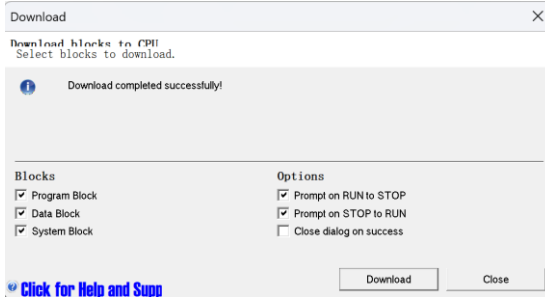
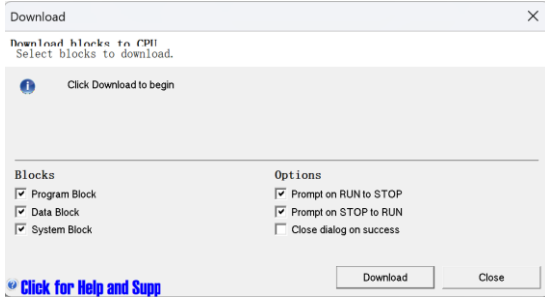
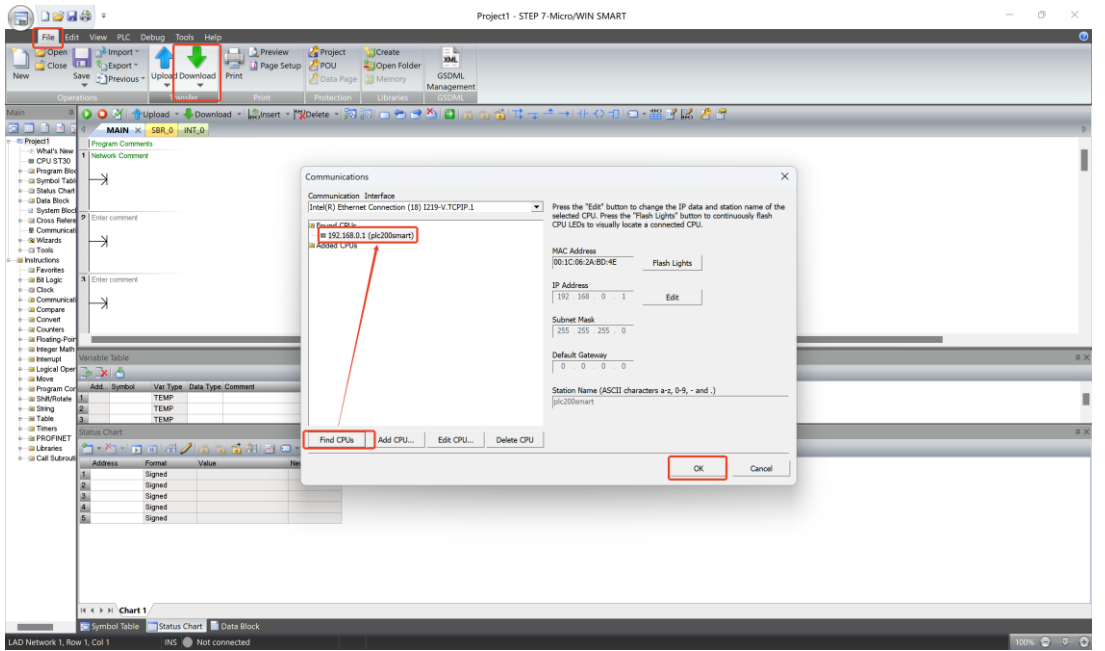

After the download is successful, open the status chart and monitor the channel value of the IO modules.

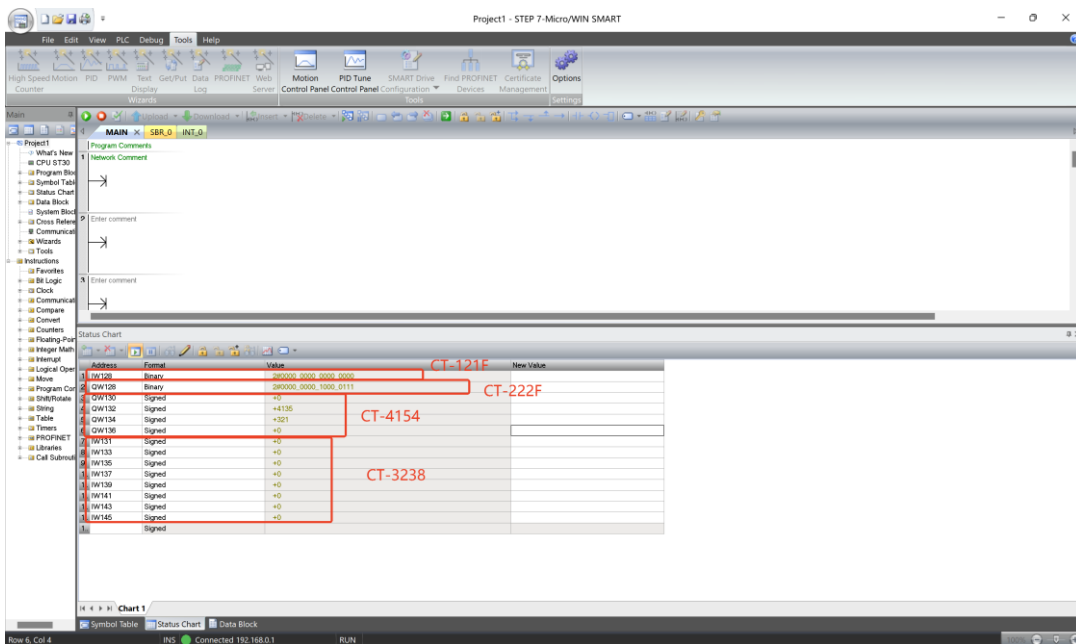

Example of communication for the BN-8033 module

1 Topology

EtherCAT Master communication topology diagram

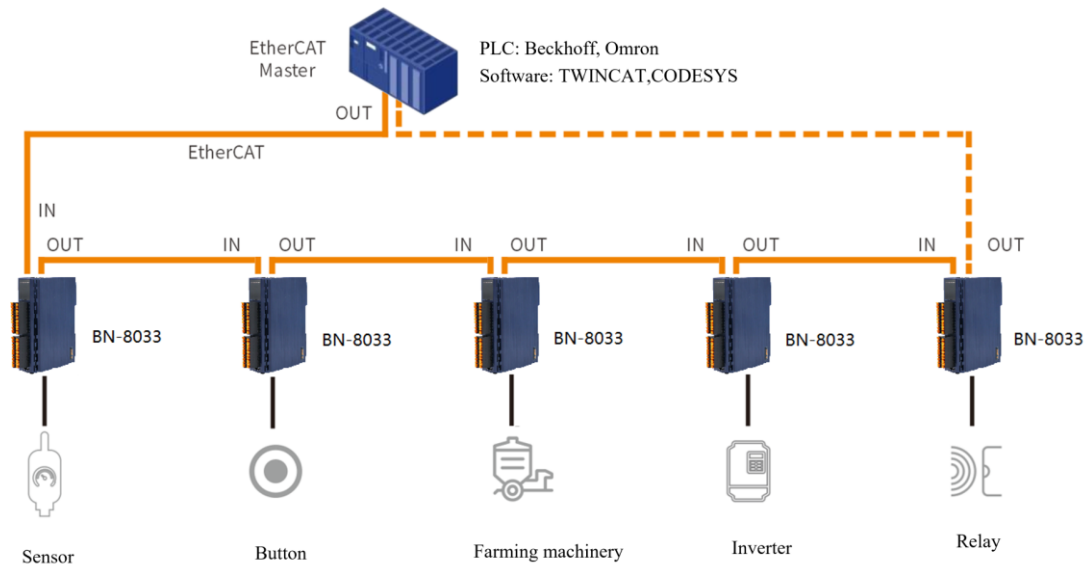

2 Example of communication between TwinCAT 3 software and module

Note: There are two ways to test the module: either directly using the scanning function of TwinCAT 3 or manually importing the XML file and configuring the IO manually.

Preparation: IO modules: B32-EC-11-26 (BN-8033, BT-124F, BT-222F). Note: BT-124F has added a sub-module with counting function.

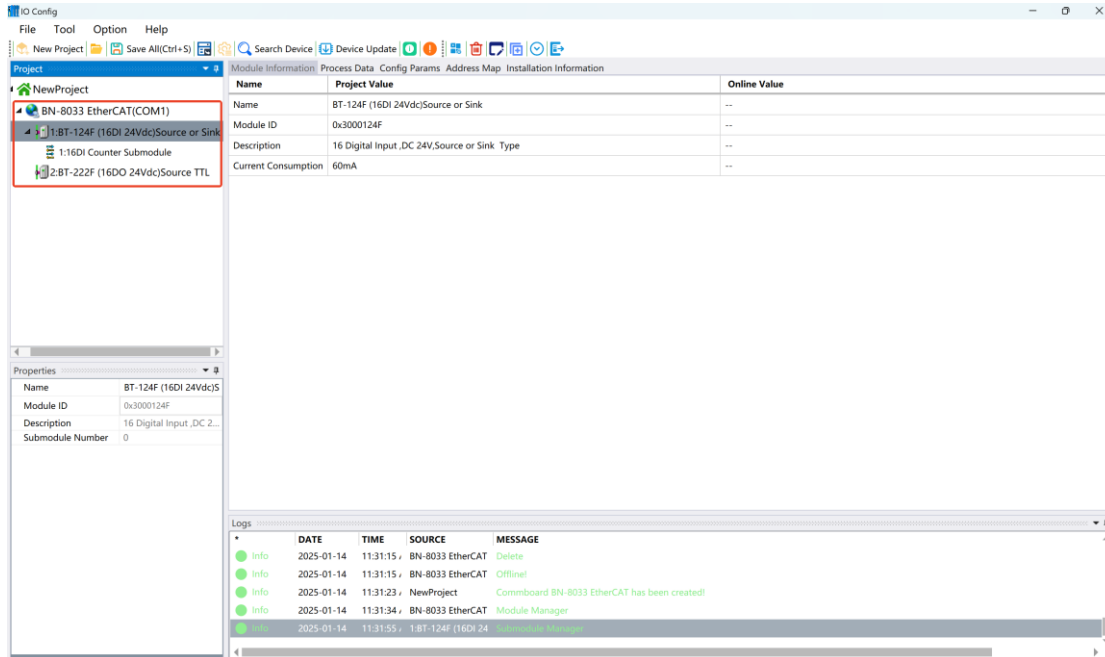

Power on the module BN-8033 and connect it to the PC network port from the ECAT IN interface of the BN-8033 (**EtherCAT communication strictly distinguishes input and output, and the interface cannot be connected incorrectly, otherwise the module communication may be abnormal**).

1. Open the TwinCAT XAE software, click FILE -> New -> Project, and the interface will pop up as shown in the figure below.

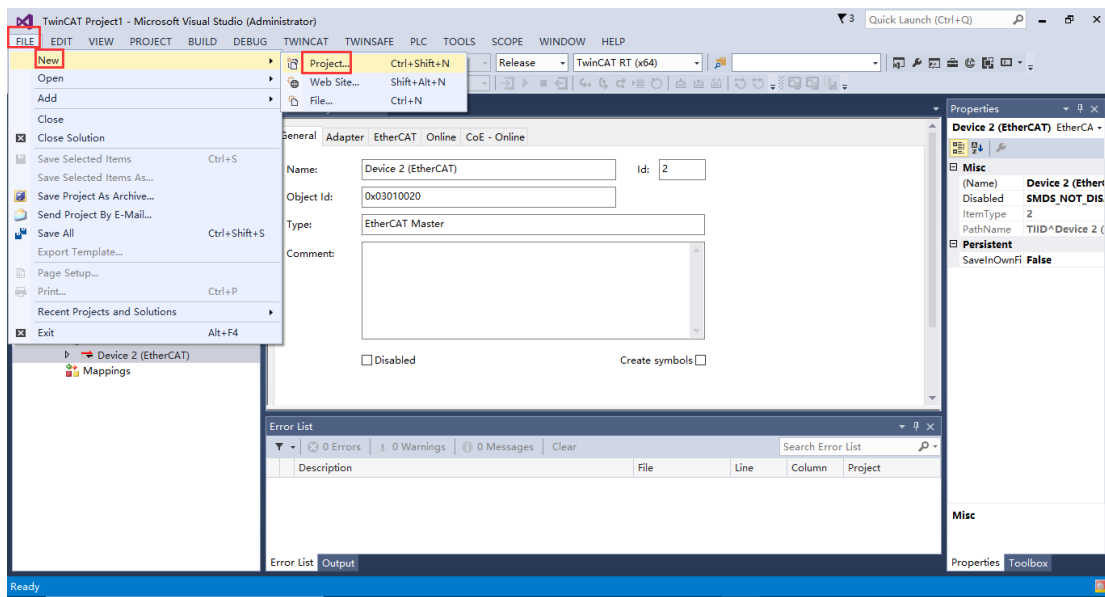

Select TwinCAT Projects as shown on the screen and select TwinCAT XAE Project in the middle of the interface, and leave the rest as default (name, location, and solution

name can be modified as needed), and click the OK button.

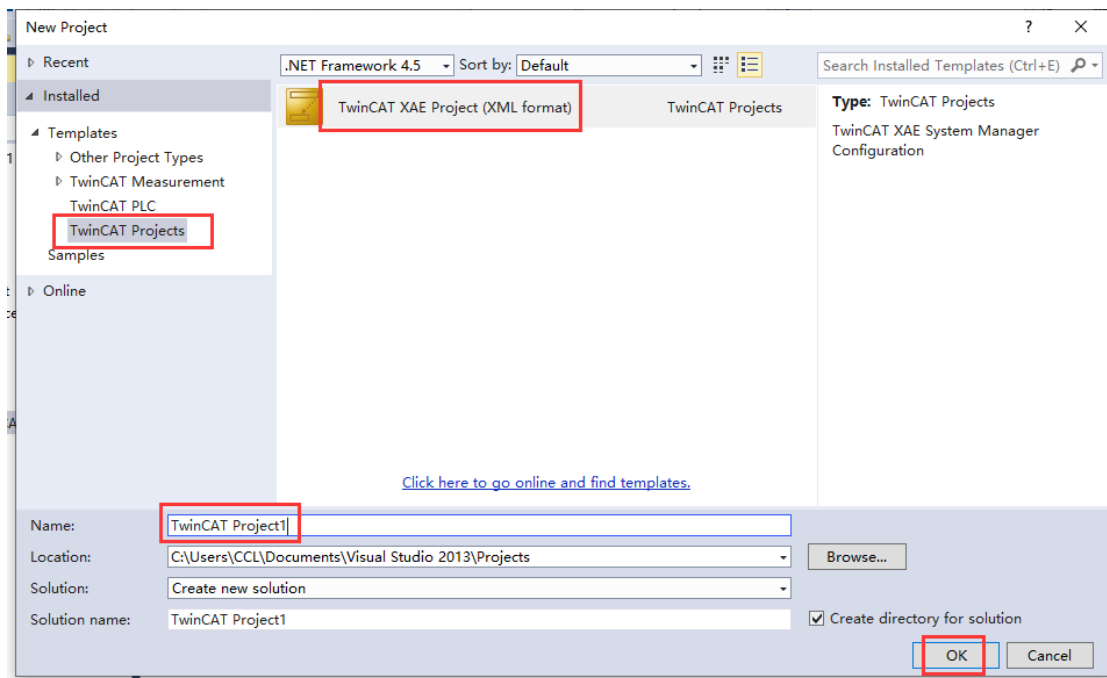

2. Module test

There are two ways to test modules: either directly with the scanning function of TwinCAT 3 or manually by importing XML files and configuring IO manually. When testing and using, users can choose one of them.

A. TwinCAT 3 software Scan Test (**Note: It is not allowed to install the XML file in the directory C:\TwinCAT\3.1\Config\Io\EtherCAT**).

Click the I/O-> Device -> Scan, click OK - OK - Yes - Yes in the pop-up interface.

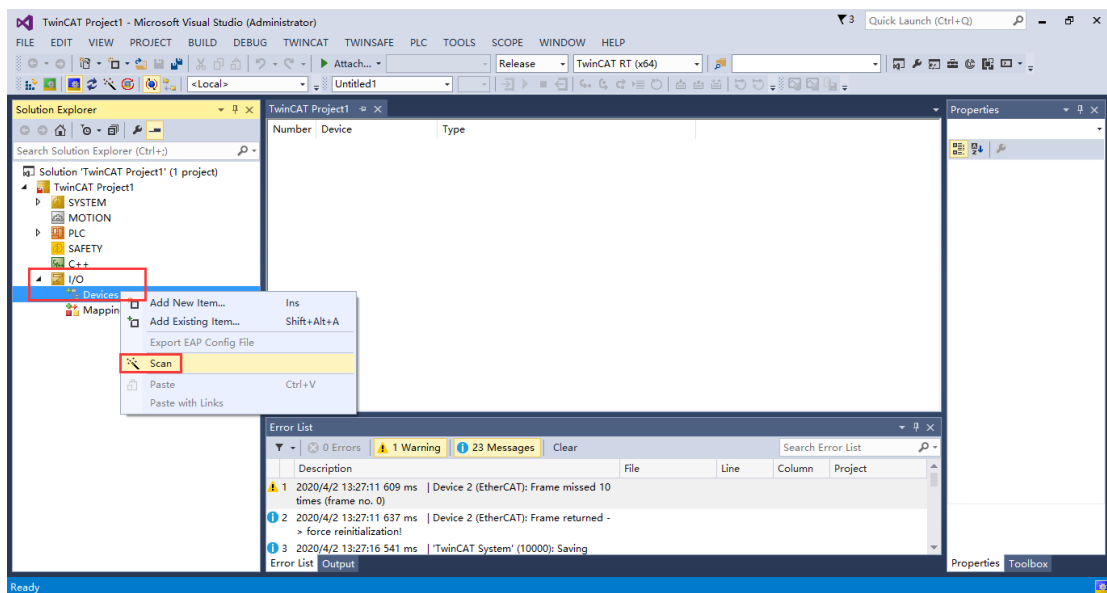

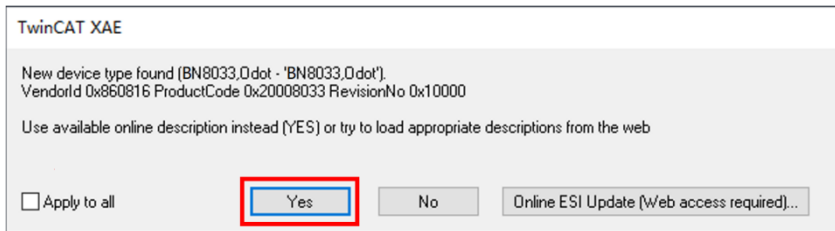
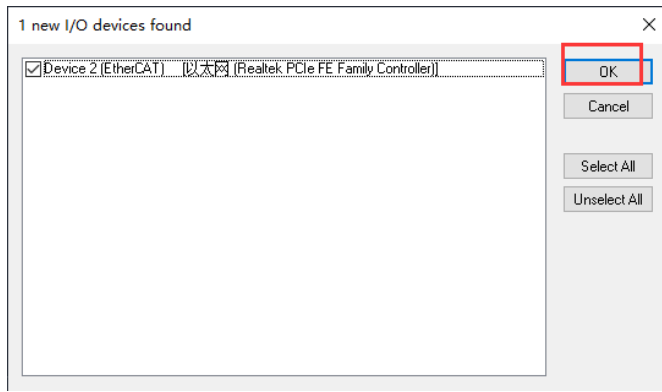

Click the Yes button in the interface to enable communication between BN-8033 and TwinCAT, and the left interface has been scanned for the module.

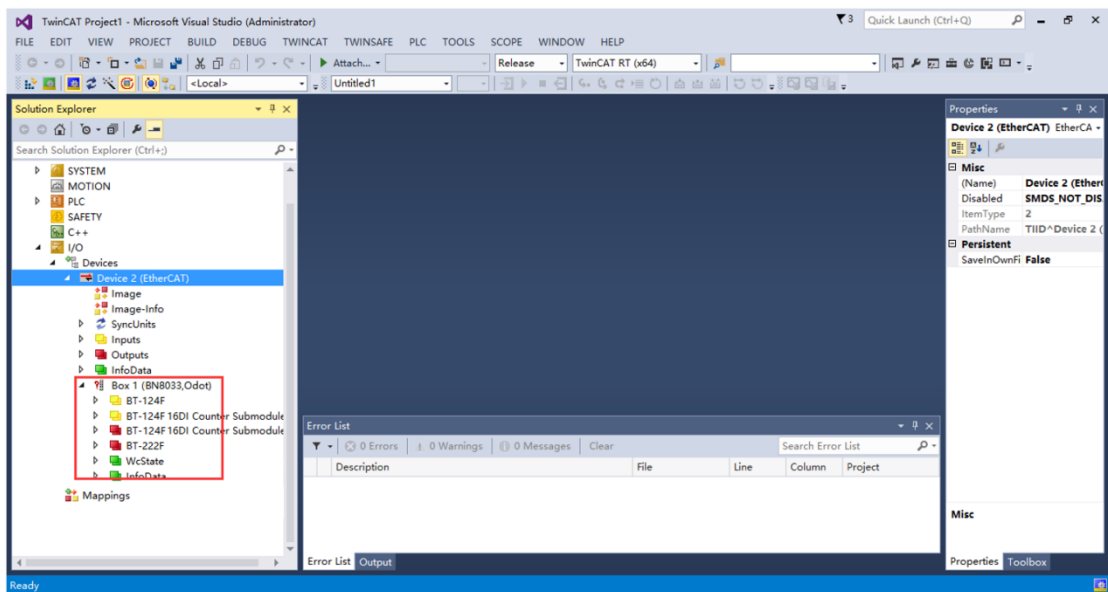

Click the BT-222F digital output module, the drop-down menu Byte, click Online-Write, assign the value 255 to the module, click OK, it can see the output channel indicator of the module is on, and the software interface can display the written value.

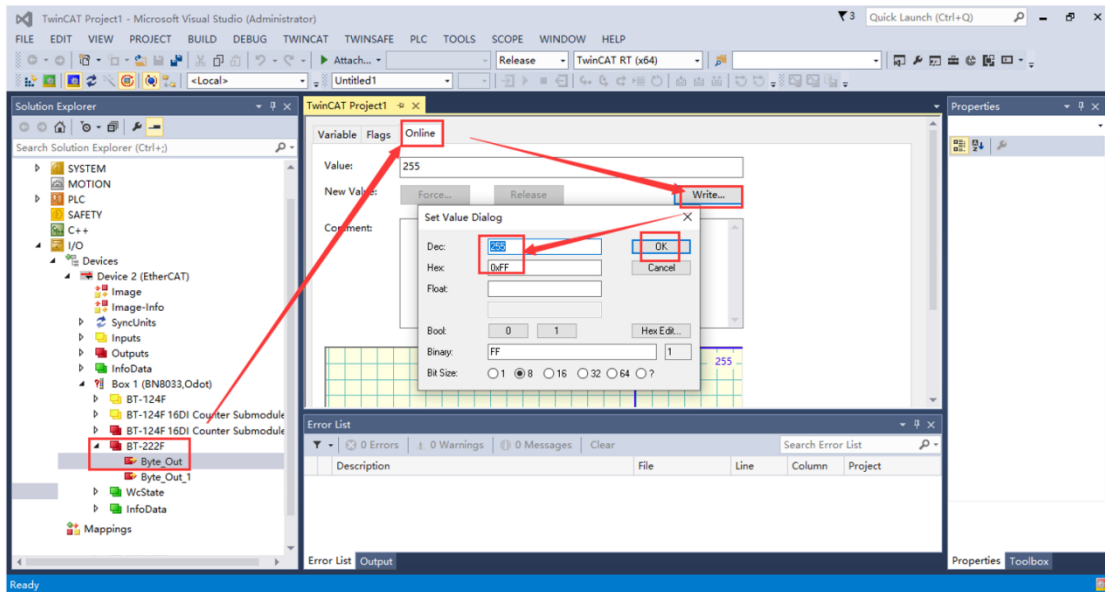

Click Box 1 (BN8033) and click Process Data to view the total number of bytes in and out. If the module is incorrect, it can first check whether the number of input and output bytes is correct.

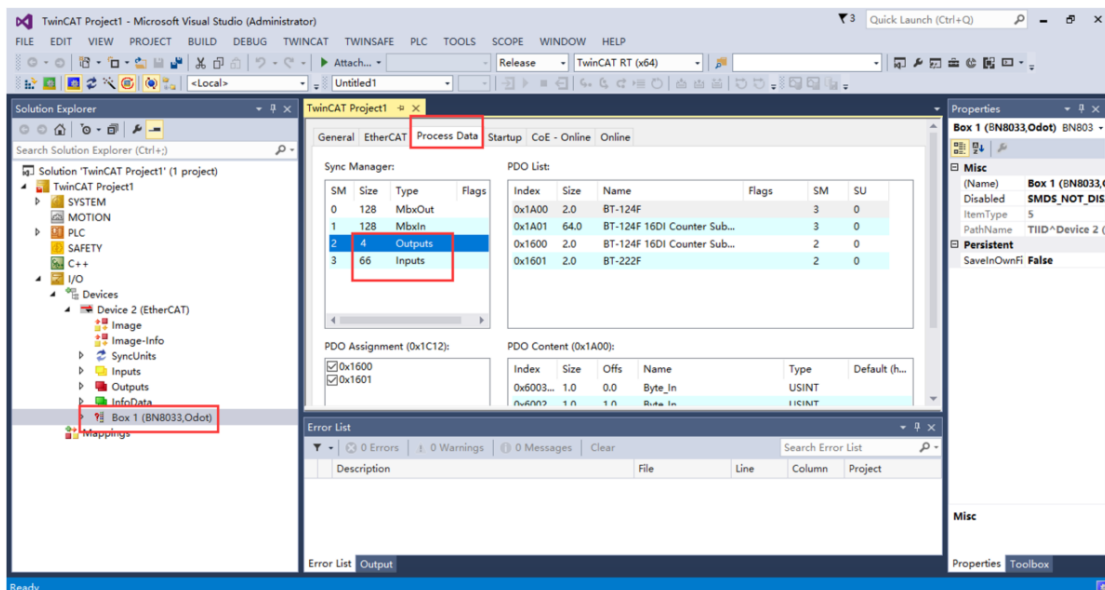

Note: The data format of the IO module that is automatically scanned is Byte, and the IO module can be scanned online for preliminary testing.

B. Manually import the XML file to configure the IO module

Copy the XML file to ...\\TwinCAT\\3.1\\Config\\Io\\EtherCAT and load the XML to TwinCAT as shown in the figure below. Note: When the XML file in this folder is updated, it must click

again to download the device description.

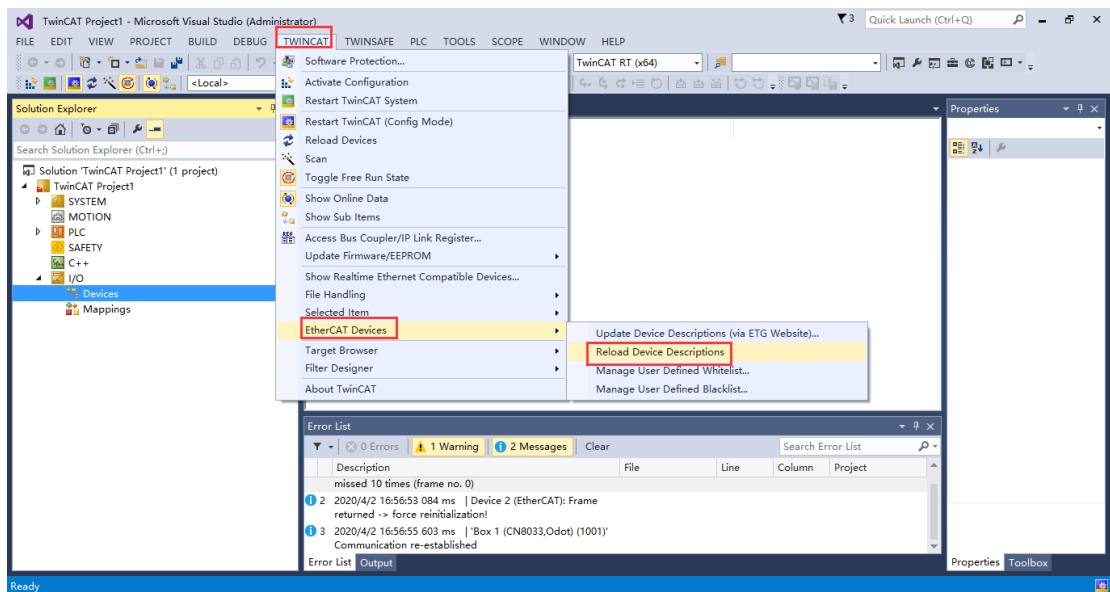
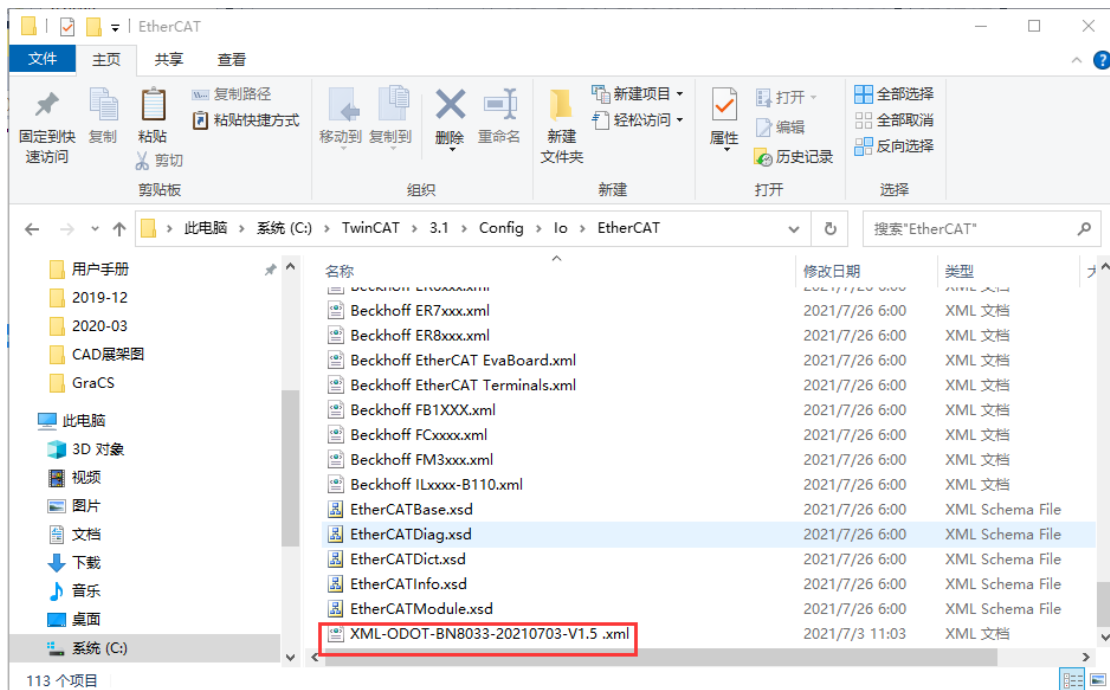

Right click the Device-> Add New Item, the interface shown in the following figure, select EtherCAT Master and click the OK button, in the new pop-up interface, select the network card and click the OK button.

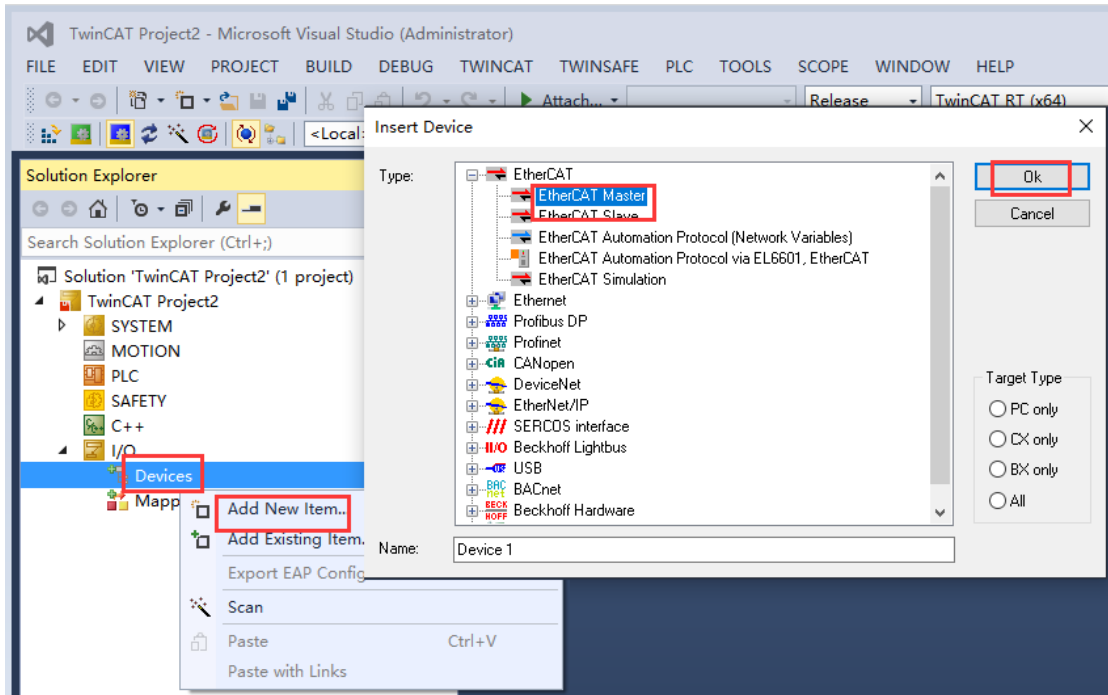

Right click the Device 1 (EtherCAT) -> Add New Item, the interface shown in the following figure. Select it in the newly popped up screen ‘BN-8033 EtherCAT Adapter.Odot’, and click the OK button.

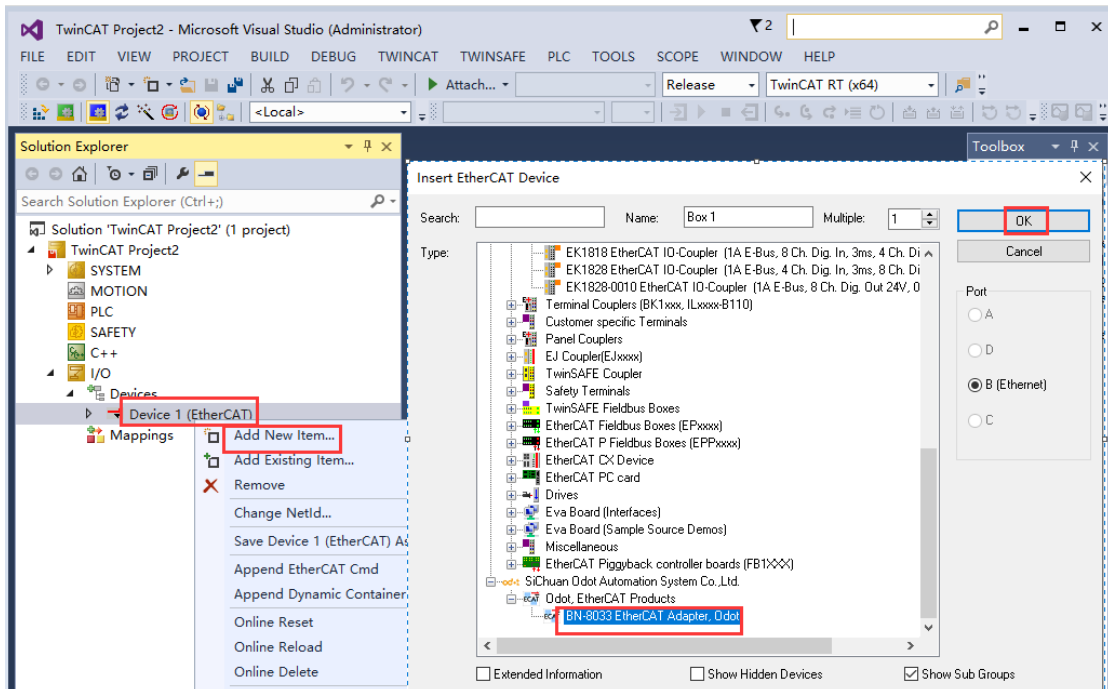

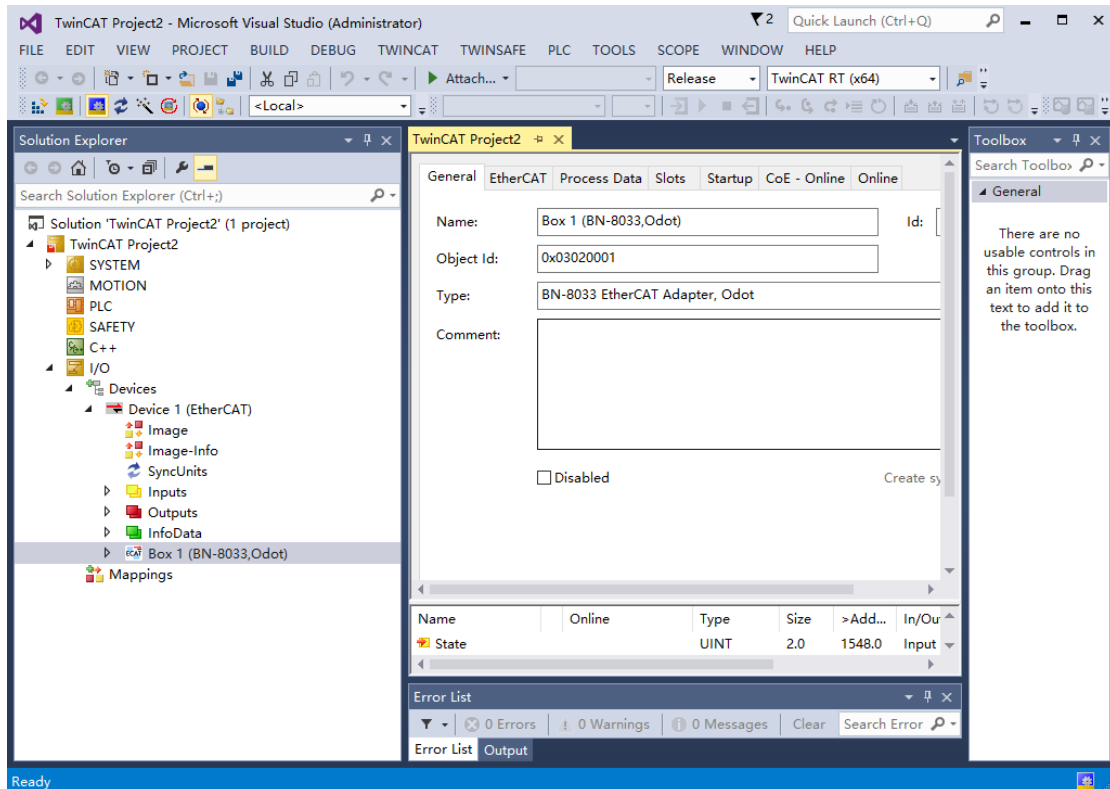

Double-click BOX 1 (BN8033), click Slots on the right side, click Terminals in the middle of the interface, and select the IO module of the corresponding slot of BN8033 on the right to map to the left. **The BT124F submodule 16DI Counter indicates that the counting function is supported.**

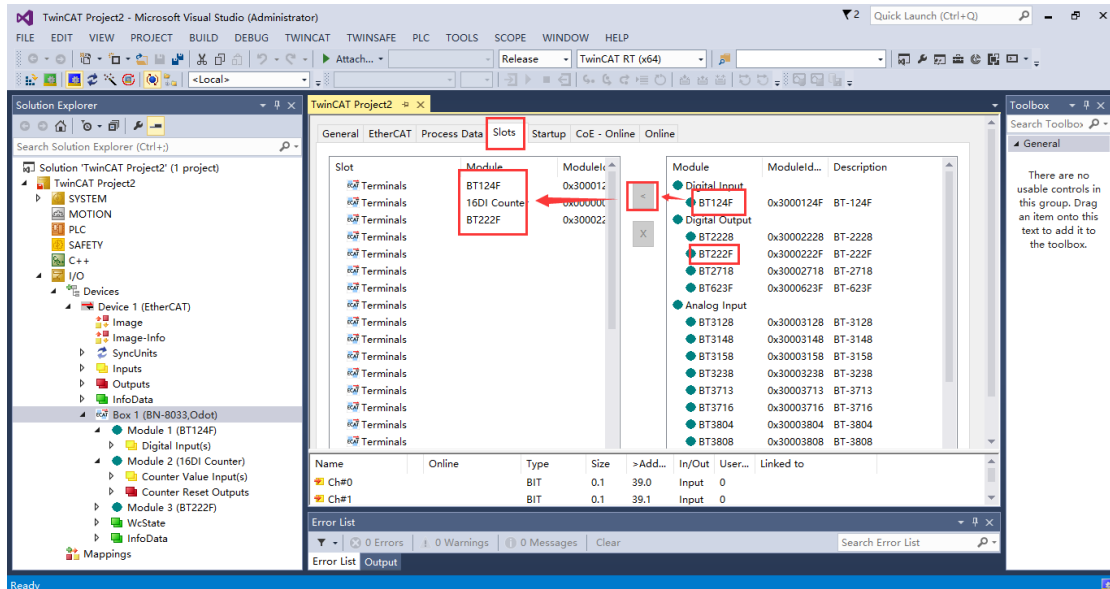

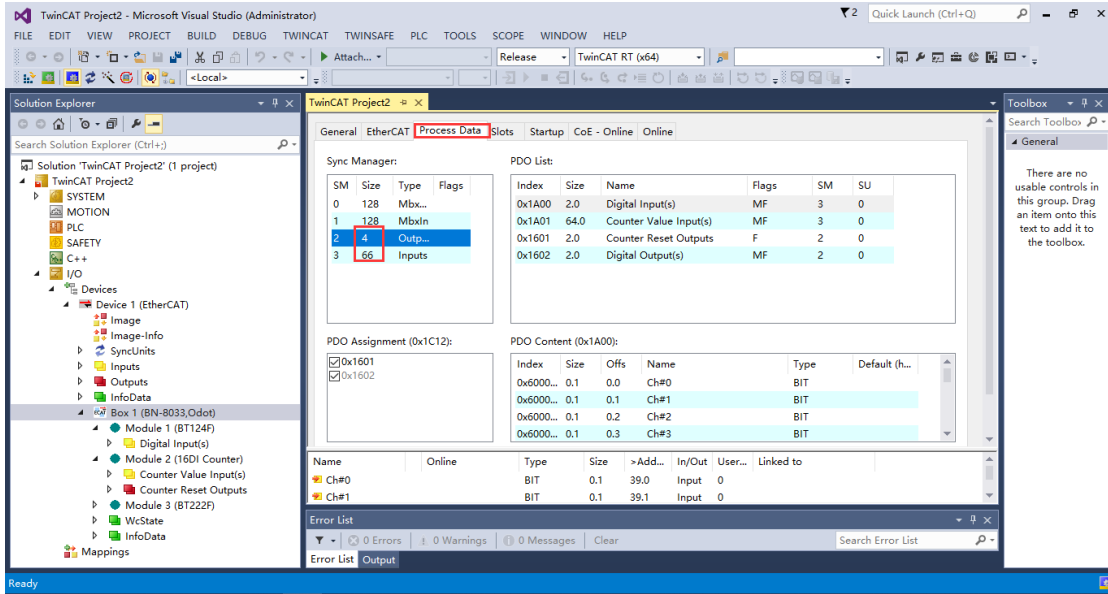

After the manual configuration is completed, click TWINCAT-Restart TwinCAT (Config Mode)-load I/O Devices-Activate Free Run, complete the configuration, download and activate the free-run mode.

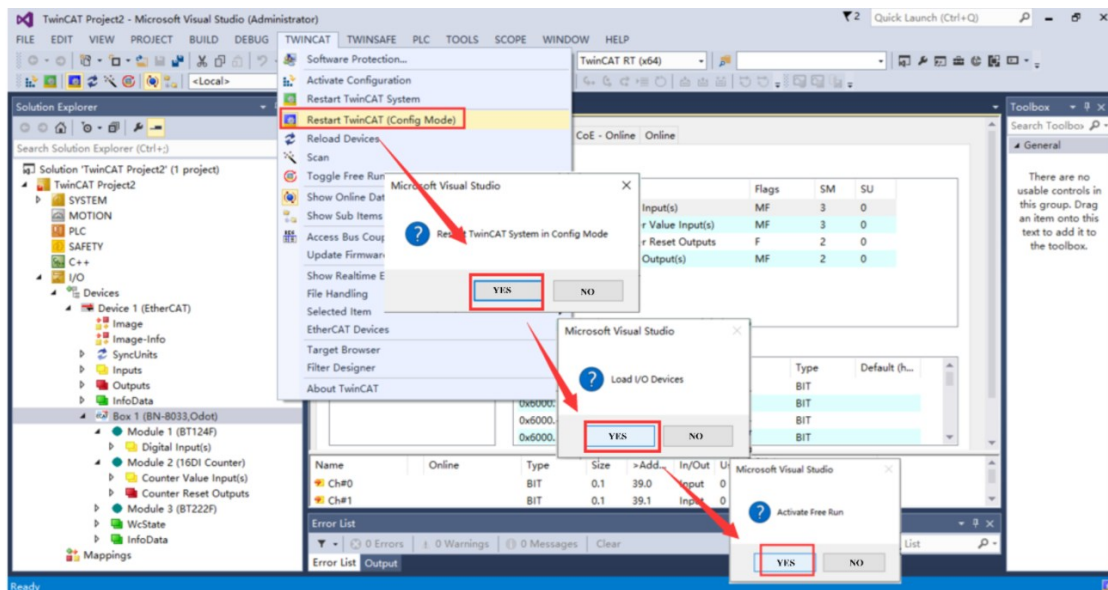

After the operation mode is activated, the IO point can be tested. It can view the input/output address of the I/O module:
 BT-124F Digital Input: 39.0~40.7, Count Storage Input: 41~104, Count Zero Output: 39.0~40.7,
 BT-222F Digital output: 41.0~42.7.

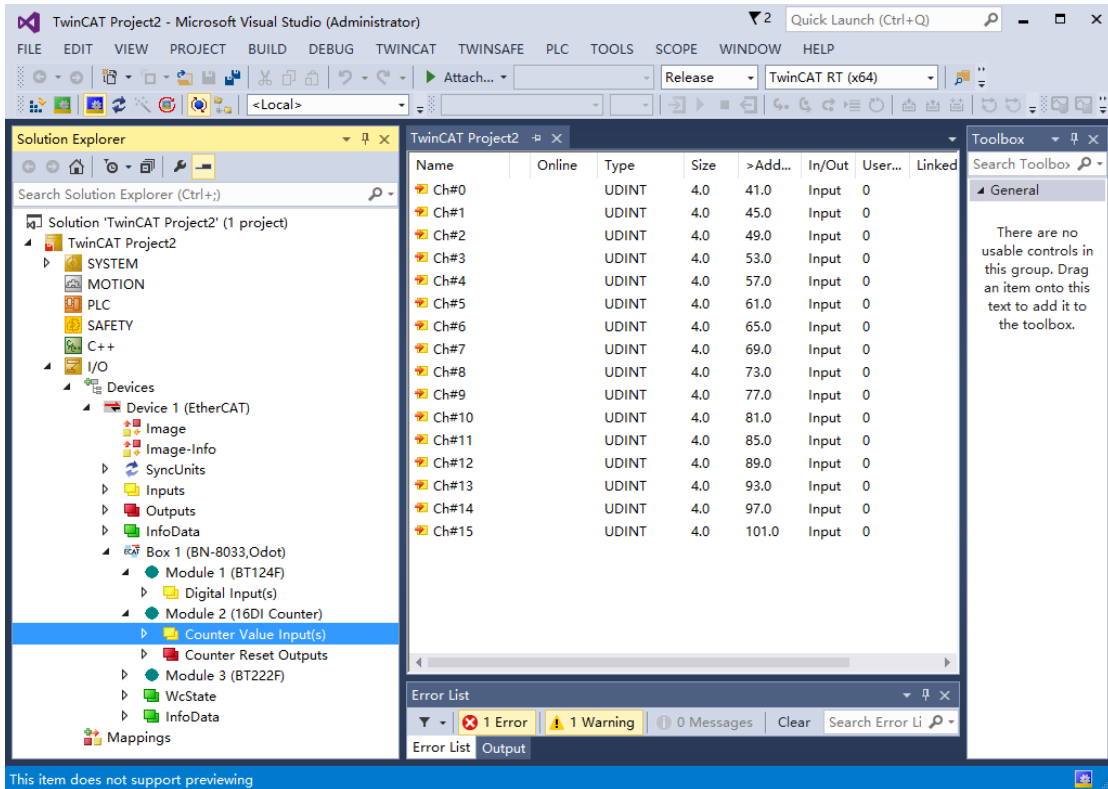
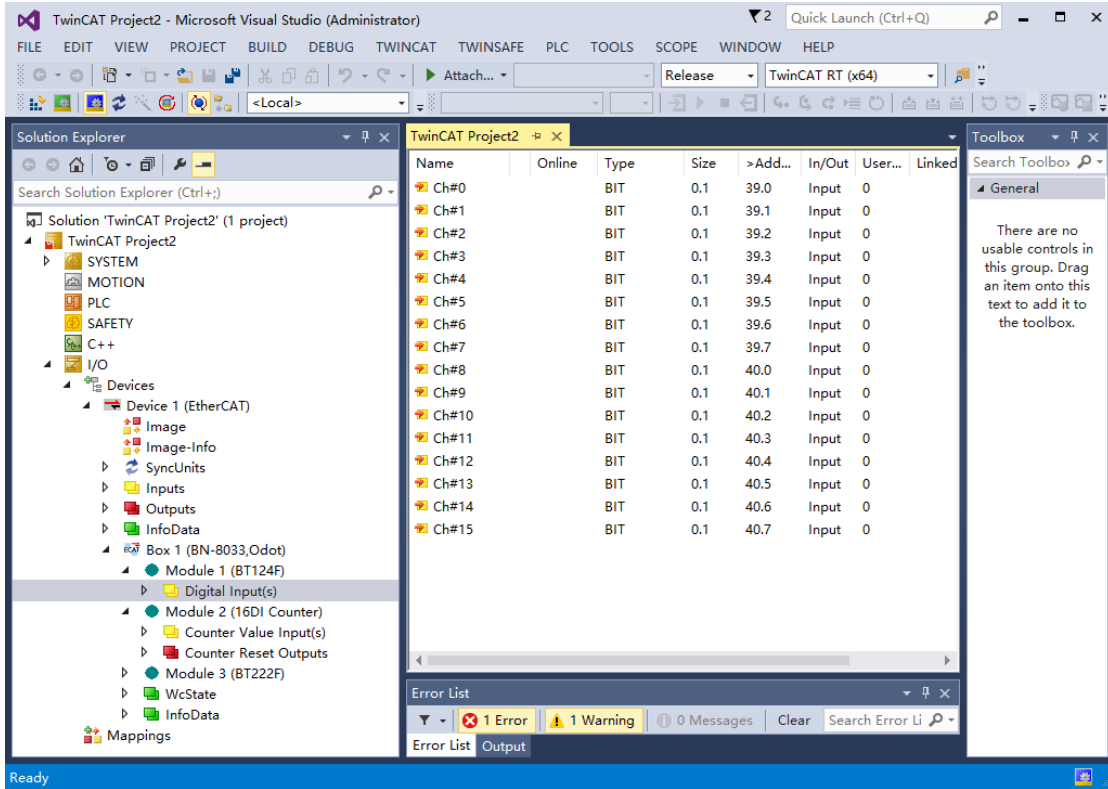

The point test can be done on a single channel, or the PLC program can be edited for testing.

Communication example of the BN-8034 module

1 Topology

Ethernet/IP Communication topology diagram

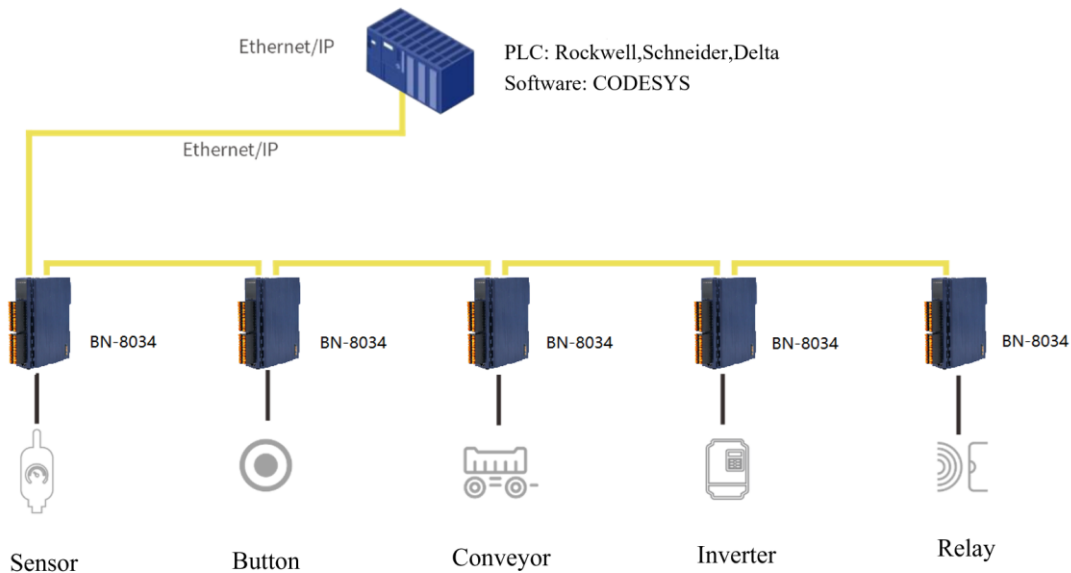

2 Example of communication between Rockwell 1769 and BN-8034

Before testing, install the corresponding Rockwell software on the PC: BootP-DHCP Tool, RSLink Classic, Studio 5000.

Power the module with a 24Vdc power supply, and connect the module's PORT interface and 1769's Ethernet interface with a network cable.

Preparation: IO Module Hardware: B32-EP-3C-4P (BN-8034, BT-3238, BT-4234).

1. The IO Config software sets the BN-8034 parameters.

Use a Type C USB cable to connect the PC to the BN-8034 configuration interface, and the com port will be generated in the computer device manager. Open the IO Config software to set the IP address (192.168.1.2) and the byte size of input and output data (17 bytes for input and 8 bytes for output) of the BN-8034 module.

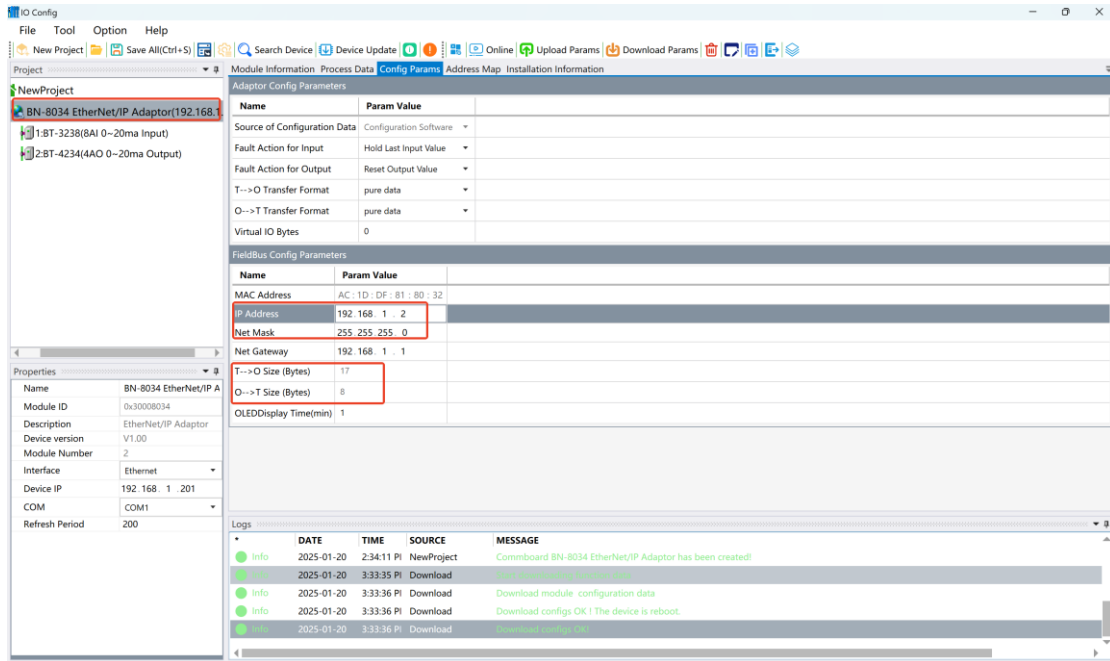

2. Rockwell software connects to BN-8034.

1. If Rockwell's PLC is used for the first time, it needs to use the BootP-DHCP Tool software to assign an IP address to the PLC. The IP address of the 1769PLC used for the test is 192.168.1.11.

2. Open the RSLink Classic software, click the Communications—Configure Drivers

or click the shortcut .

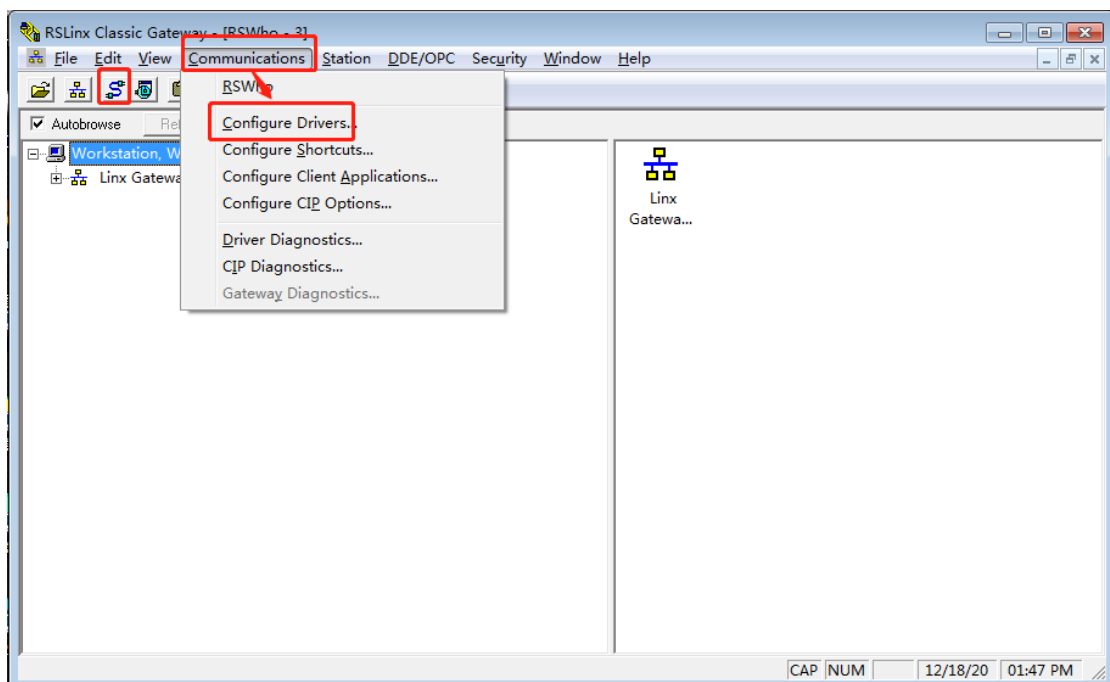

Select the Ethernet/IP Driver in Available Driver Type, click **Add New...**, added a new RSLink driver. Click OK and select the local NIC in the pop-up window.

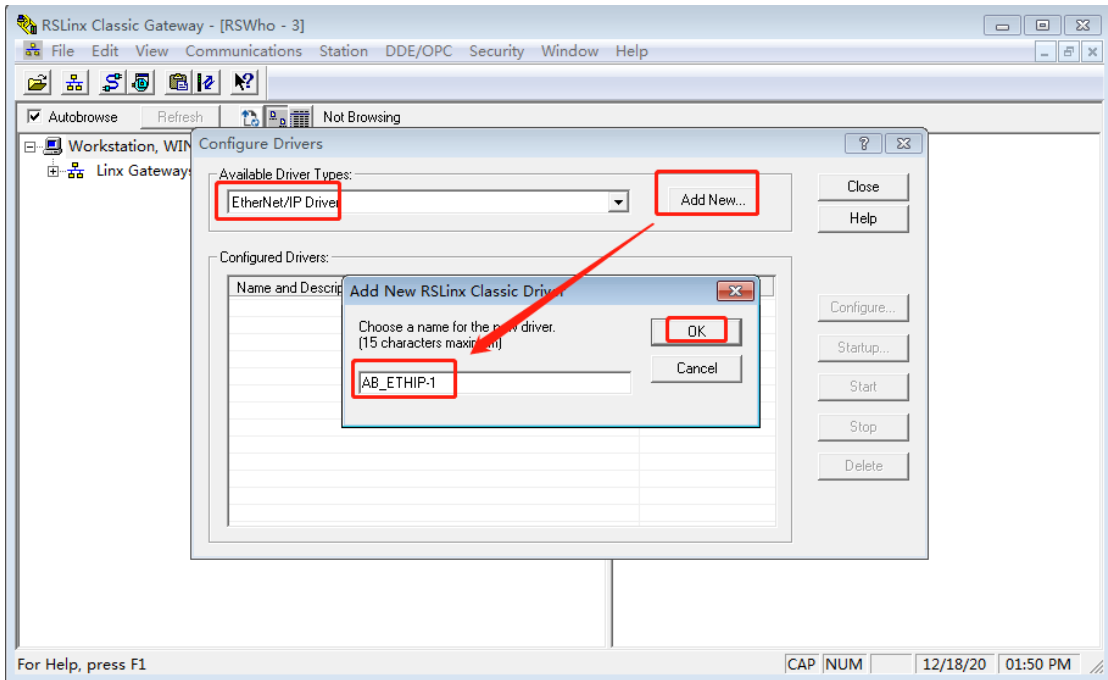
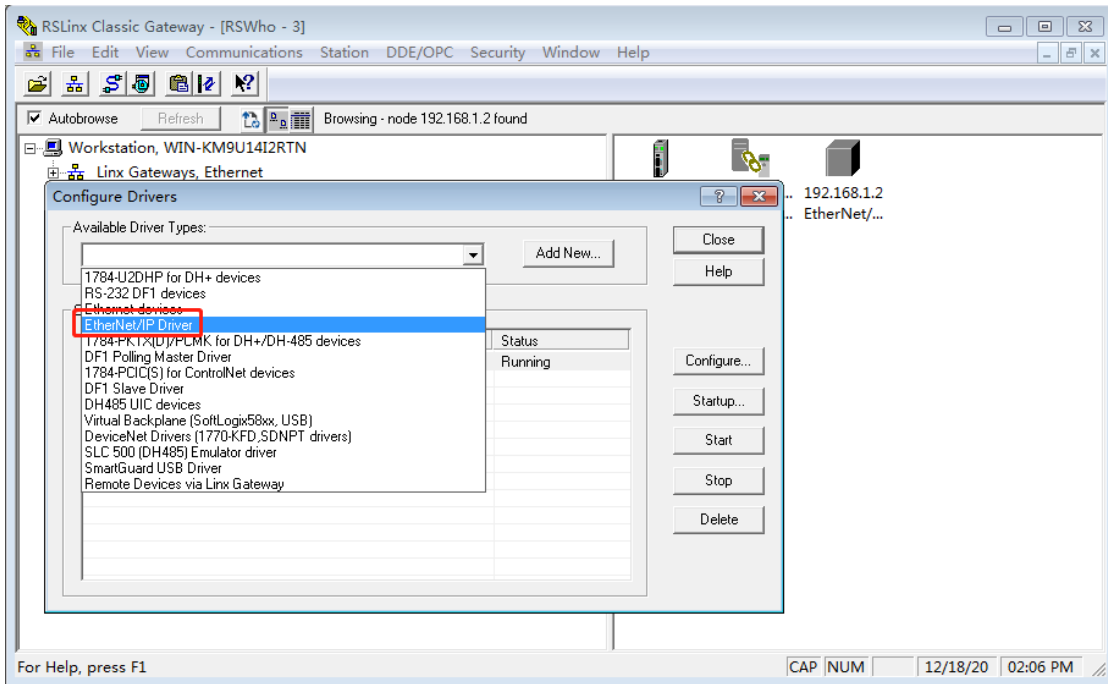

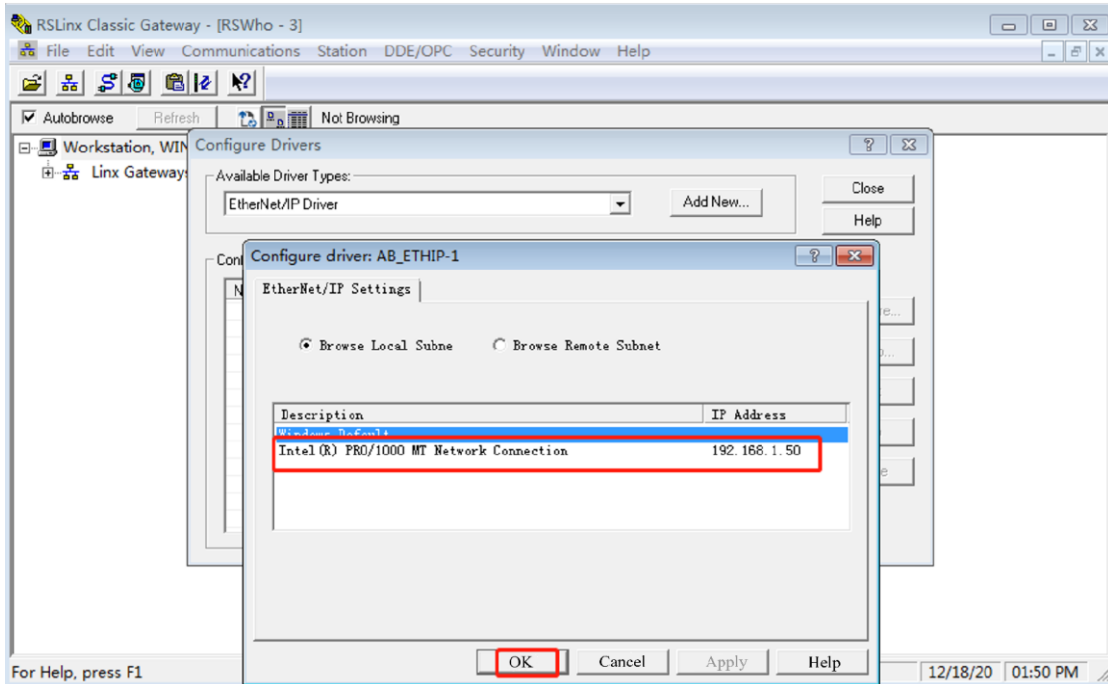

Click Communications—RSWho or click on the shortcut , it can scan all Ethernet/IP devices on the network from the new RSLink driver drop-down menu.

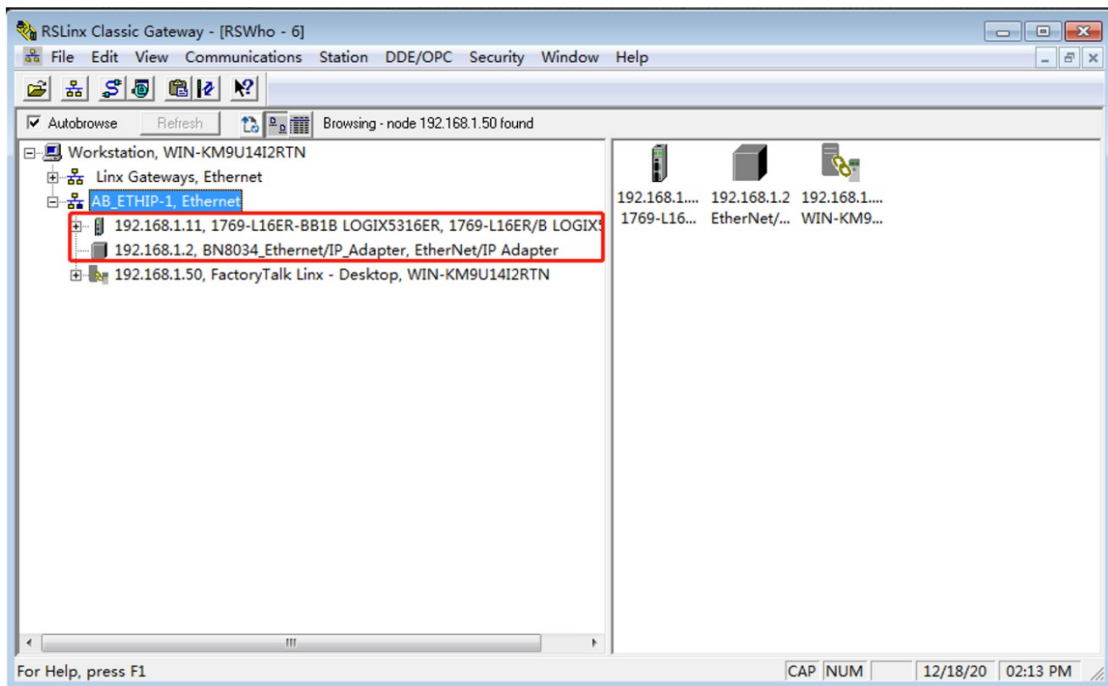

3. Open the Studio 5000 software, click New Project, select 1769-L16ER-BB1B, TEST1769 the project name, click Next, expand I/O, and select 1 module. Click Done.

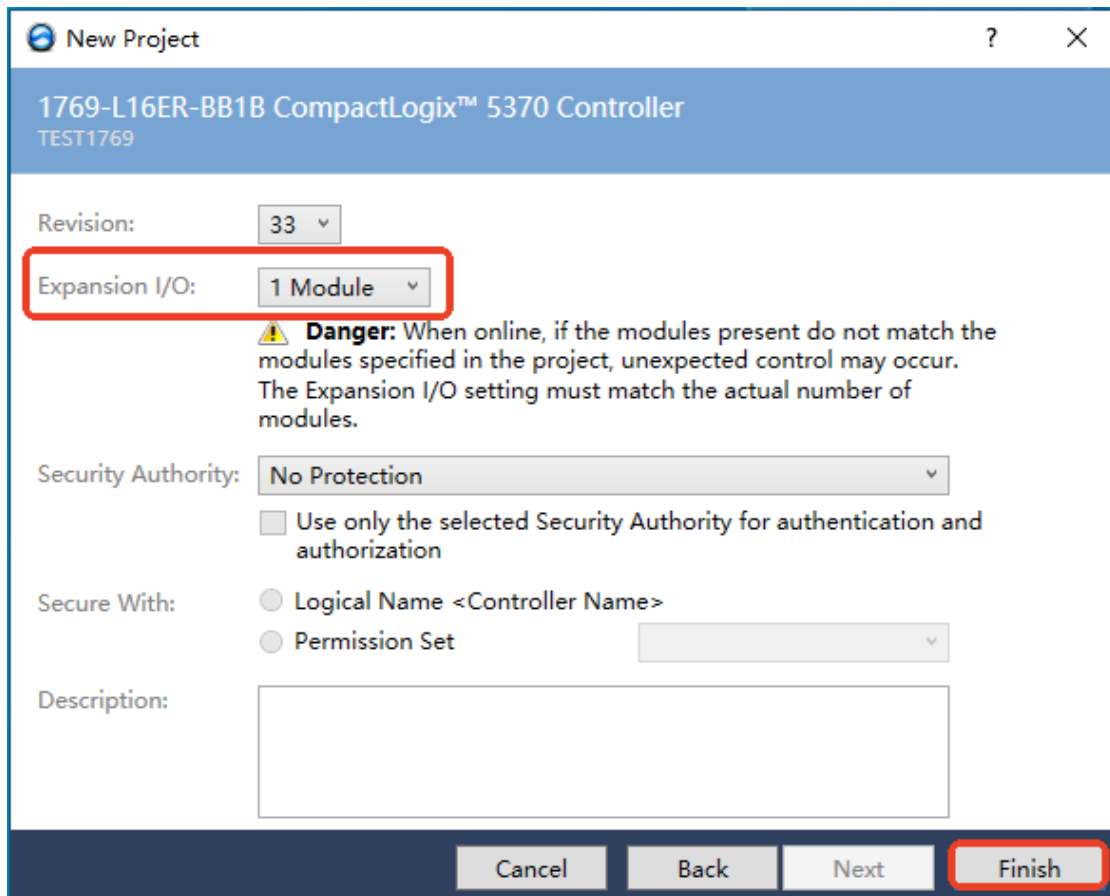
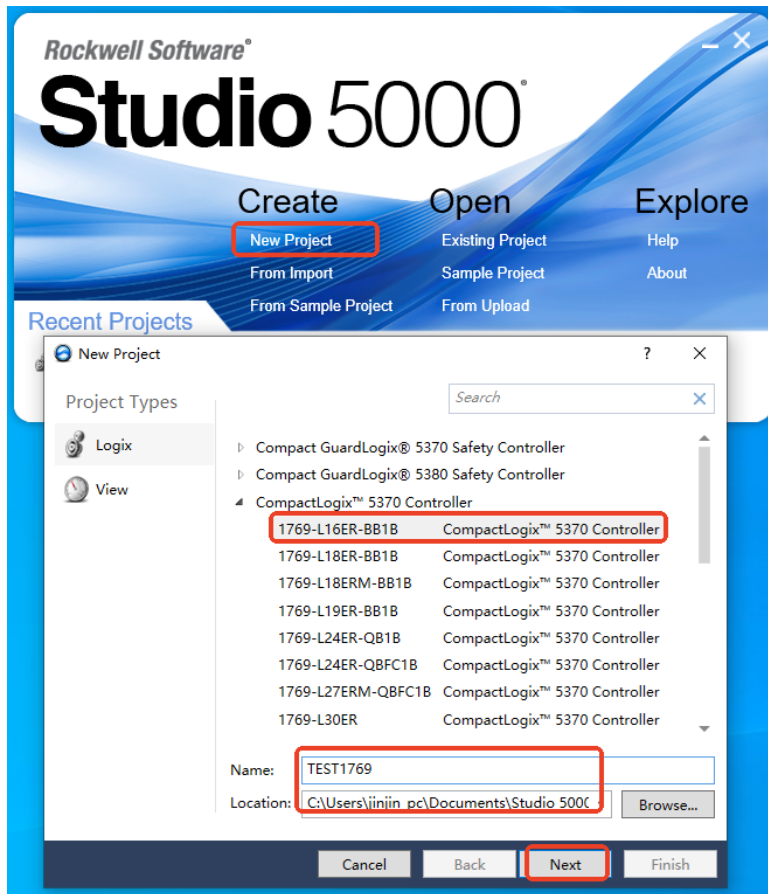

After the new project is completed, click Tools - EDS Hardware Installation Tool, click Next - Next in the pop-up window, click Browse, select the EDS file of BN-8034, and click Next until the EDS file installation is completed.

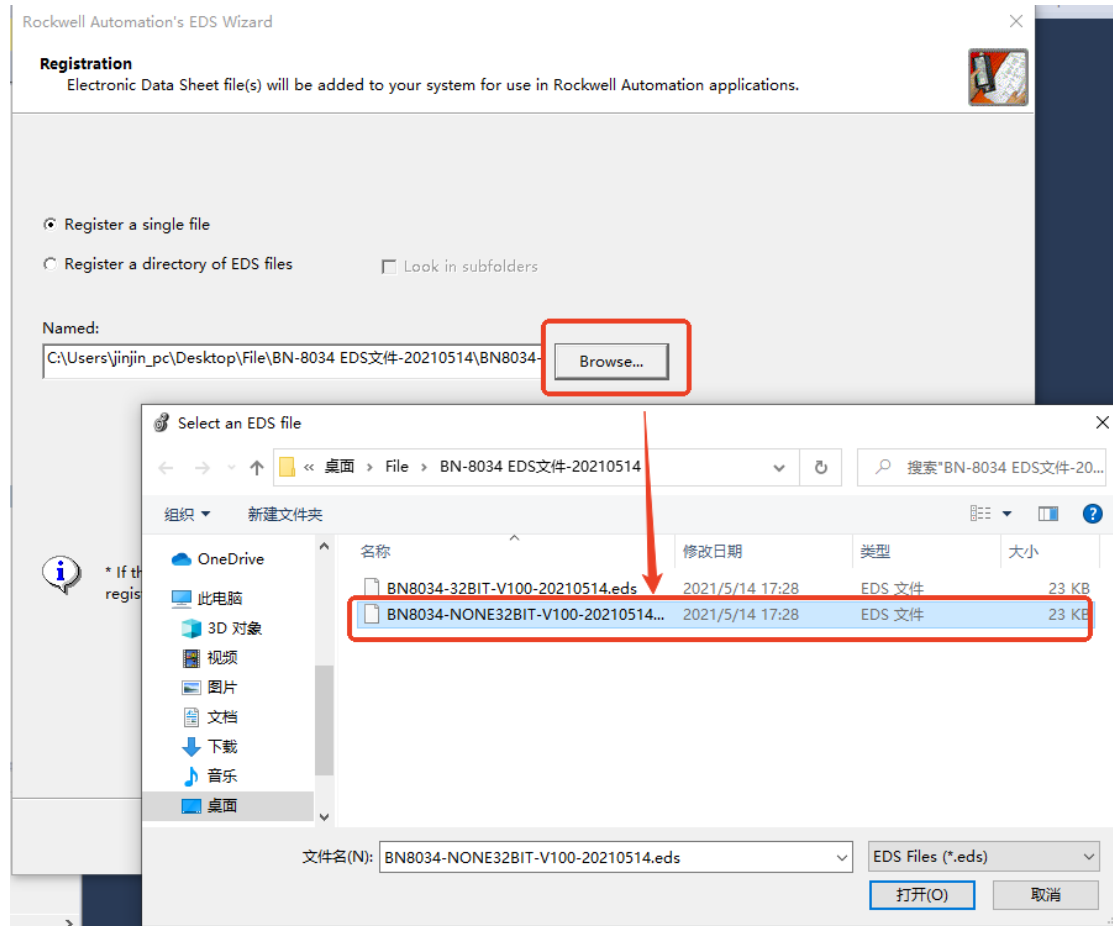

Then click Ethernet in the manager, right-click Ethernet and click New Modbule.

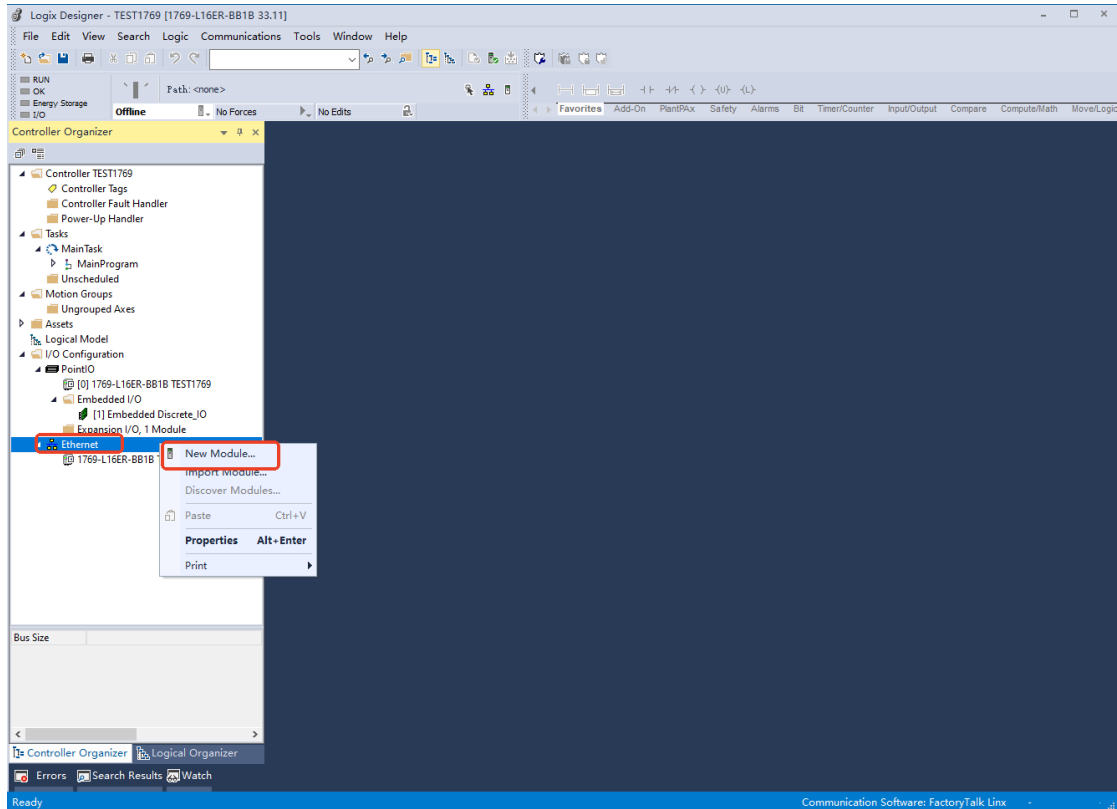

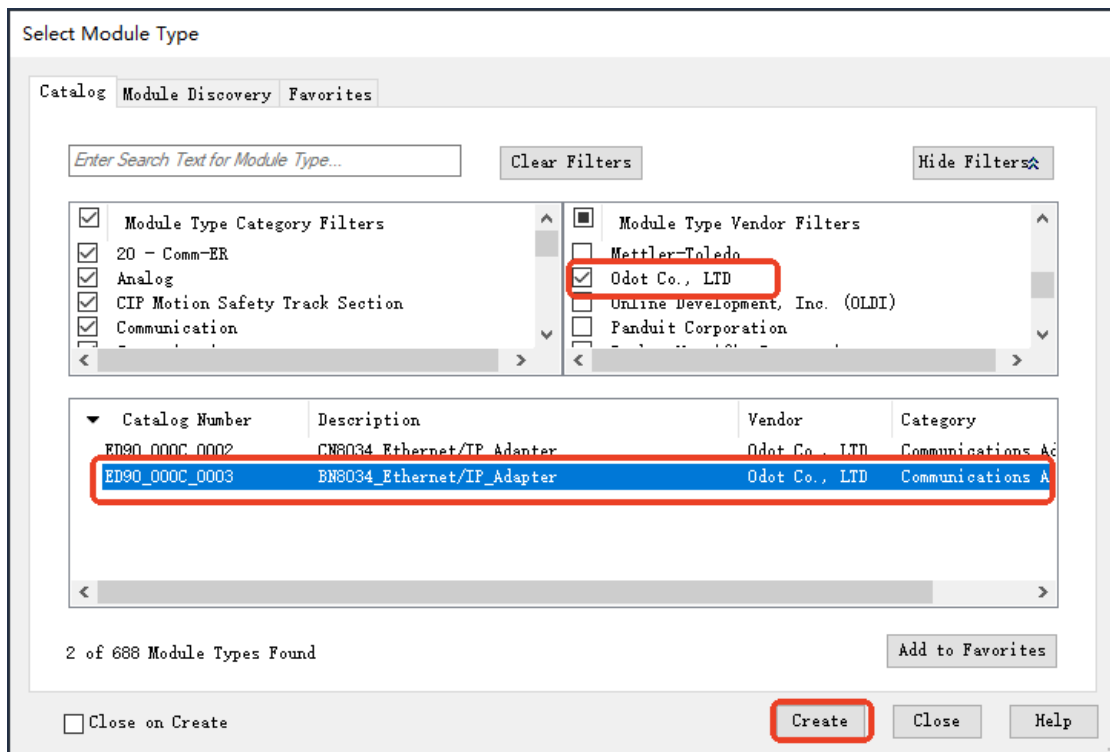

In the pop-up window, select the supplier Odot Co., LTD, select BN8034, and click Create.

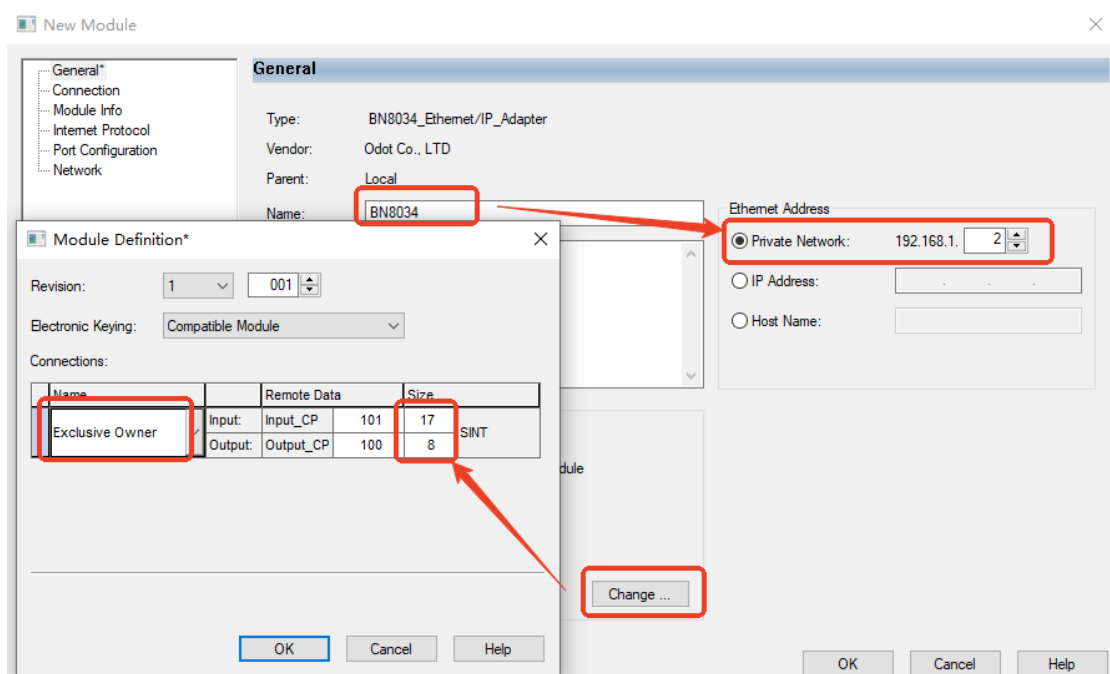
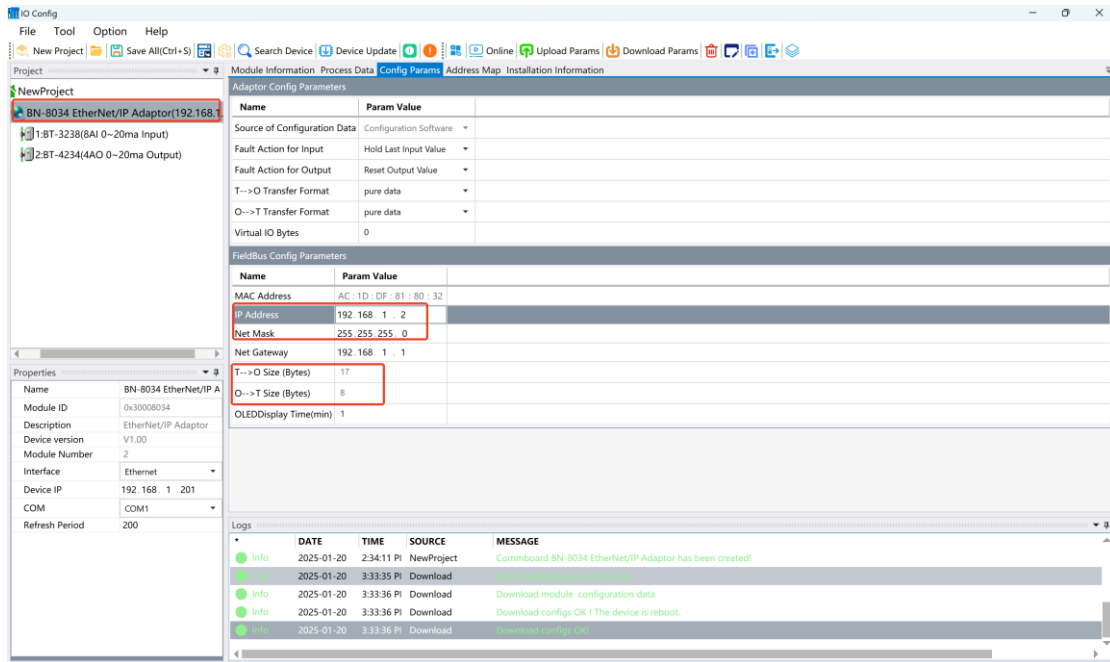

Create a new module, fill in the module name BN8034, module Ethernet IP address: 192.168.1.2 (through the IO Config software or the hardware dial address on the

module), click Change, and configure the type and size of the input and output data in the pop-up window (the byte size of the input and output data can be directly obtained through the configuration parameters of the IO Config software BN-8034). Click OK to complete the BN8034 and the attached I/O modules.



After the configuration is completed, click Save , click  Use RSWho to select the communication path, select 1769PLC in the pop-up window, and click Download

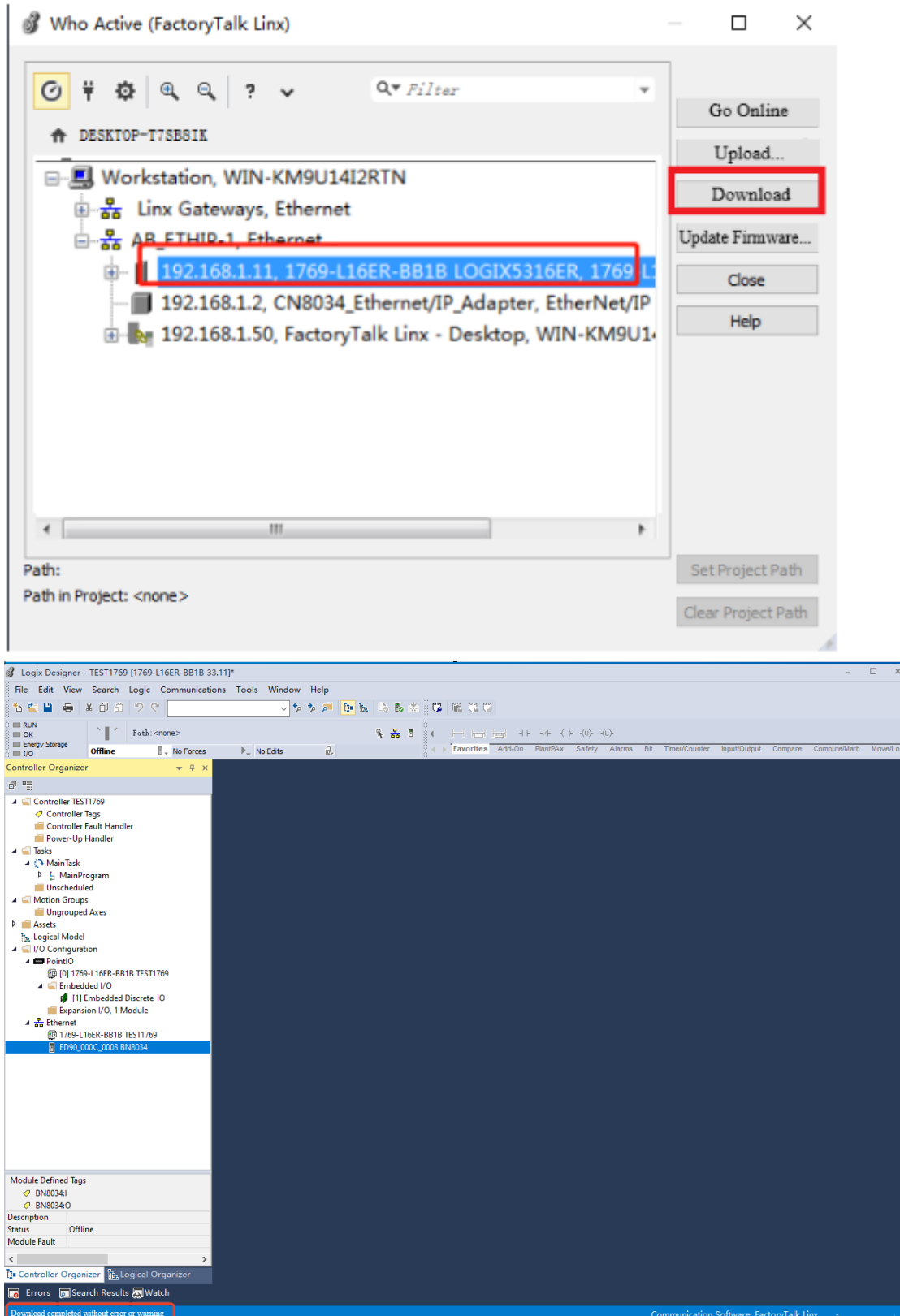

Once the download is complete, click on the Logic - Monitor tag.

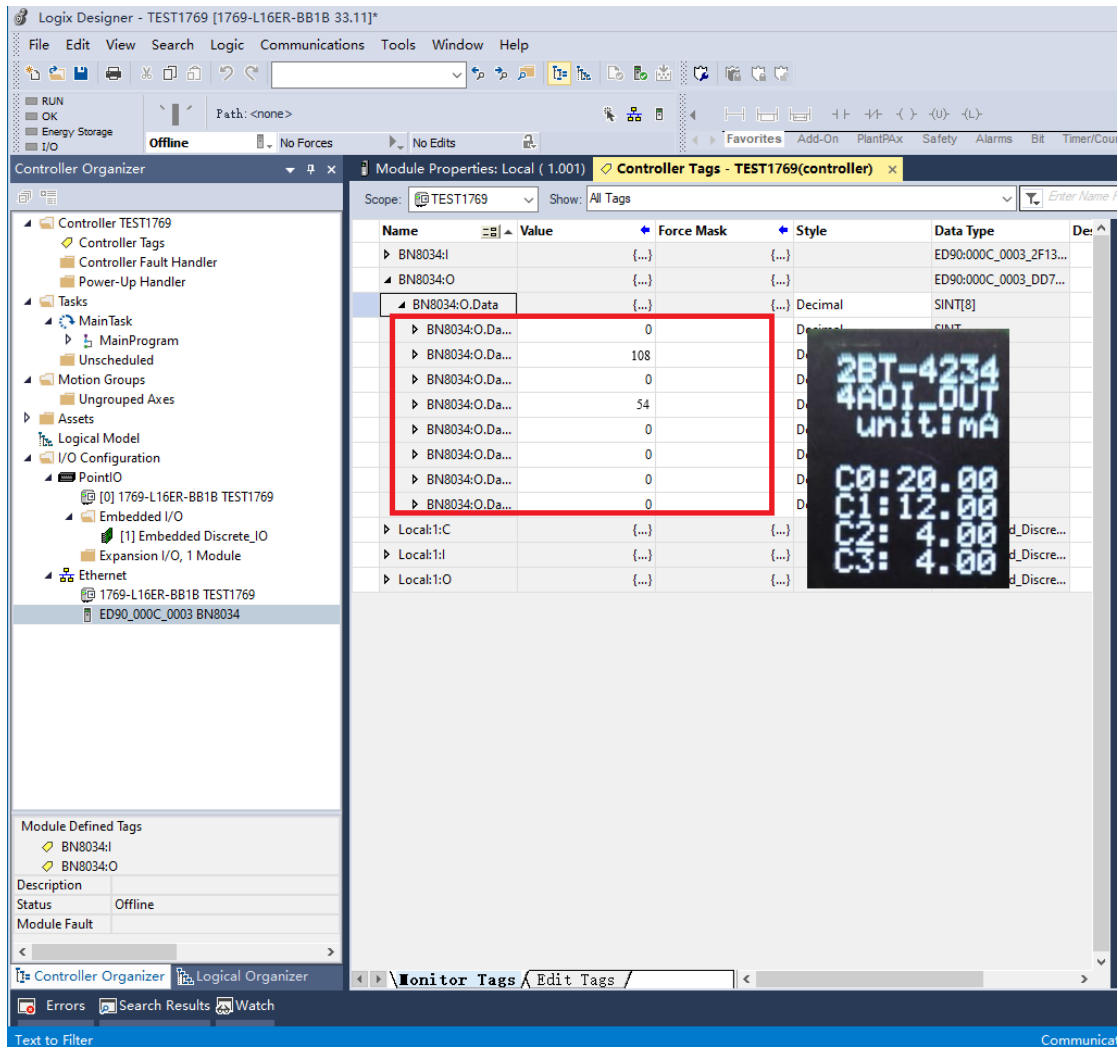

Output Channel 0:

High 108 = 16 # 6C, low 0 = 16 # 0, word high + low = 16 # 6C00 = 27648, check the CN8034 process data definition, that is, the output is 20mA current.

Output Channel 1:

High 108 = 16 # 36, low 0 = 16 # 0, word high + low = 16 # 3600 = 13824, check the CN8034 process data definition, that is, the output is 12mA current.

Output channels 2 and 3 have no value and the minimum output range is 4mA.

3 KEYENCE KV8000 and module communication example

Before testing, install the corresponding KEYENCE software: **KV STUDIO on PC.**

The module is supplied with 24Vdc, and the PORT interface and the Ethernet interface of the KV8000 are connected with a network cable. Preparation: IO modules: B32-EP-3C-4P (BN-8034, BT-3238, BT-4234).

1. The IO Config software sets the BN-8034 parameters.

Use a Type C USB cable to connect the PC to the BN-8034 configuration interface, and the com port will be generated in the computer device manager. Open the IO Config software to set the IP address (192.168.0.5) and the byte size of input and output data (17 bytes for input and 8 bytes for output) of the BN-8034 module.

Note: The byte size of the input and output data here requires the I/O parameter of BN-8034 to be uploaded.

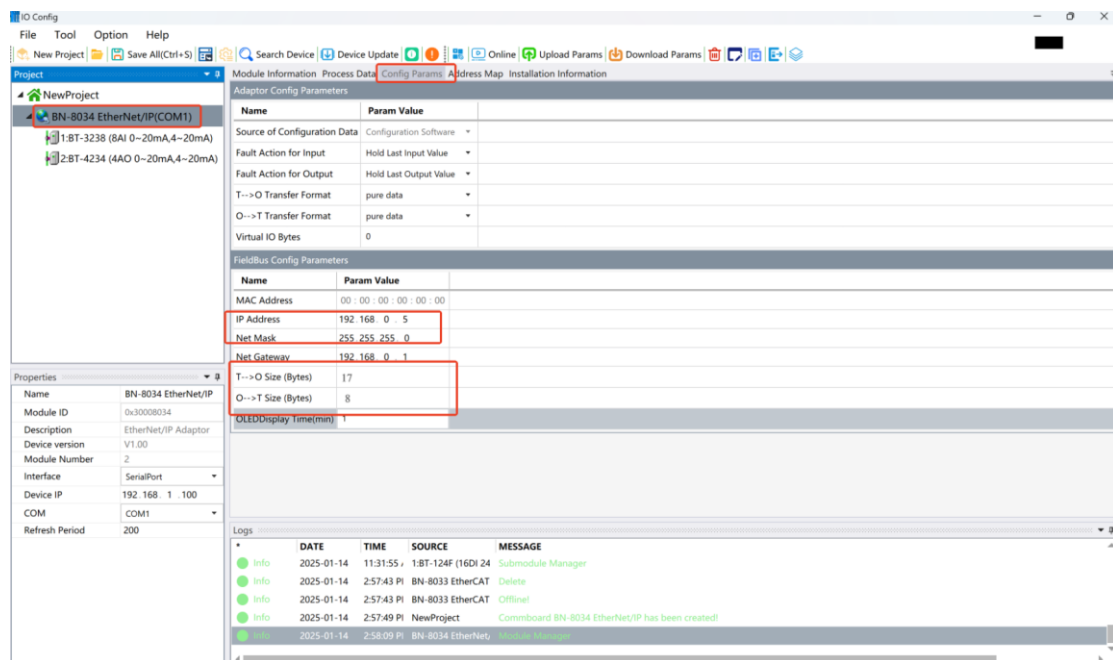

2. KEYENCE software is connected to BN-8034.

Open KV STUDIO and click New Project , Project Name: 8034test, and click OK.

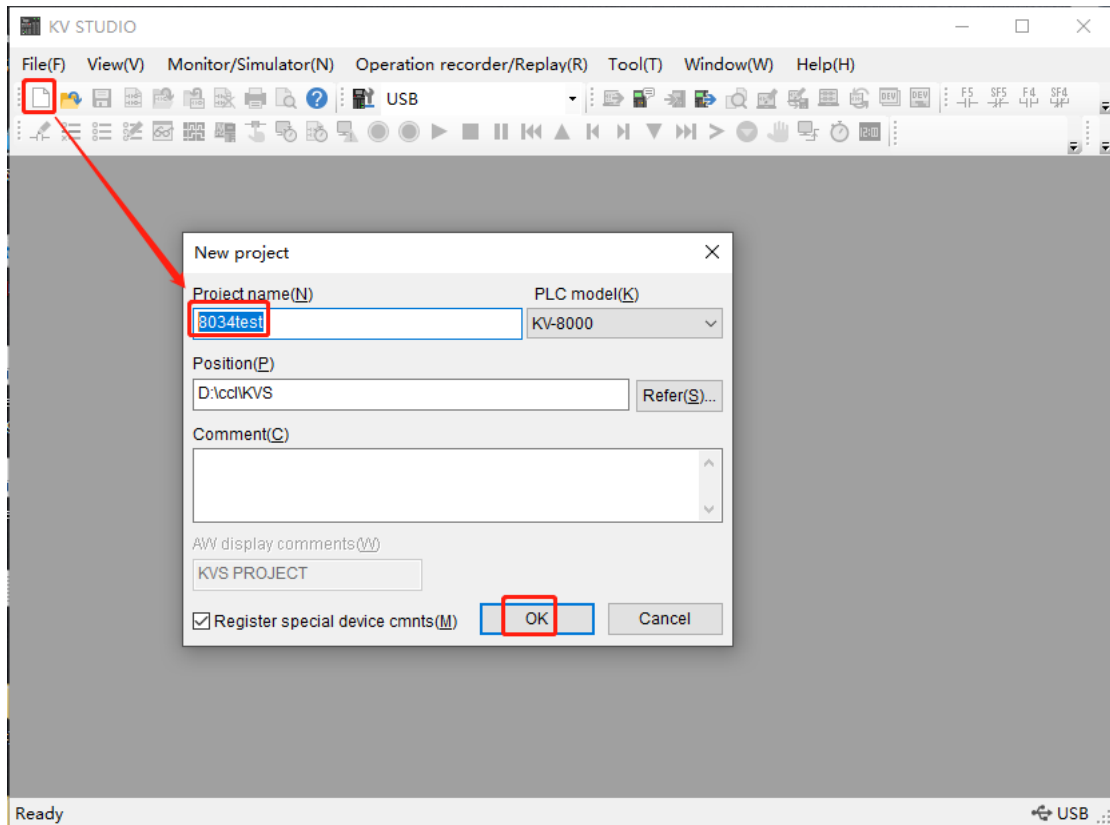

In the pop-up window, click Yes-Yes to enter the unit editing window.

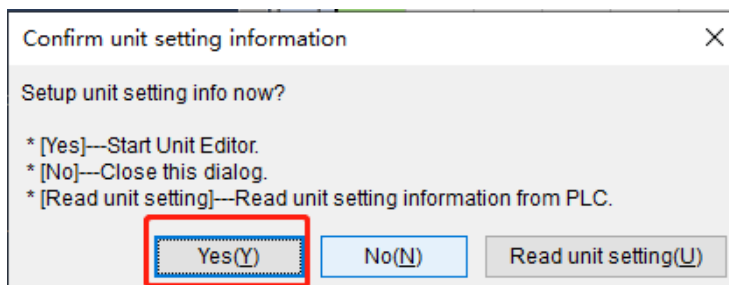
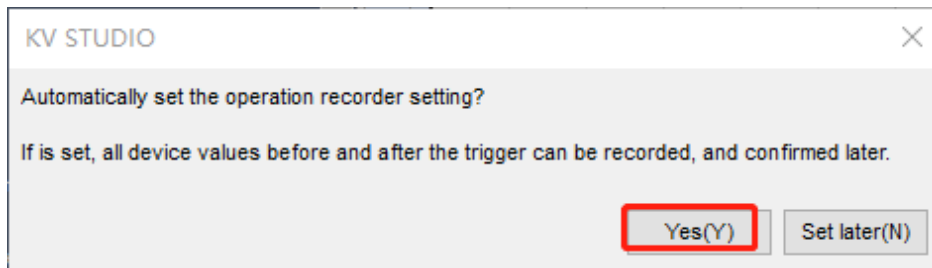

It can view the parameters of the PLC on the interface, and the IP address is:

192.168.0.10.

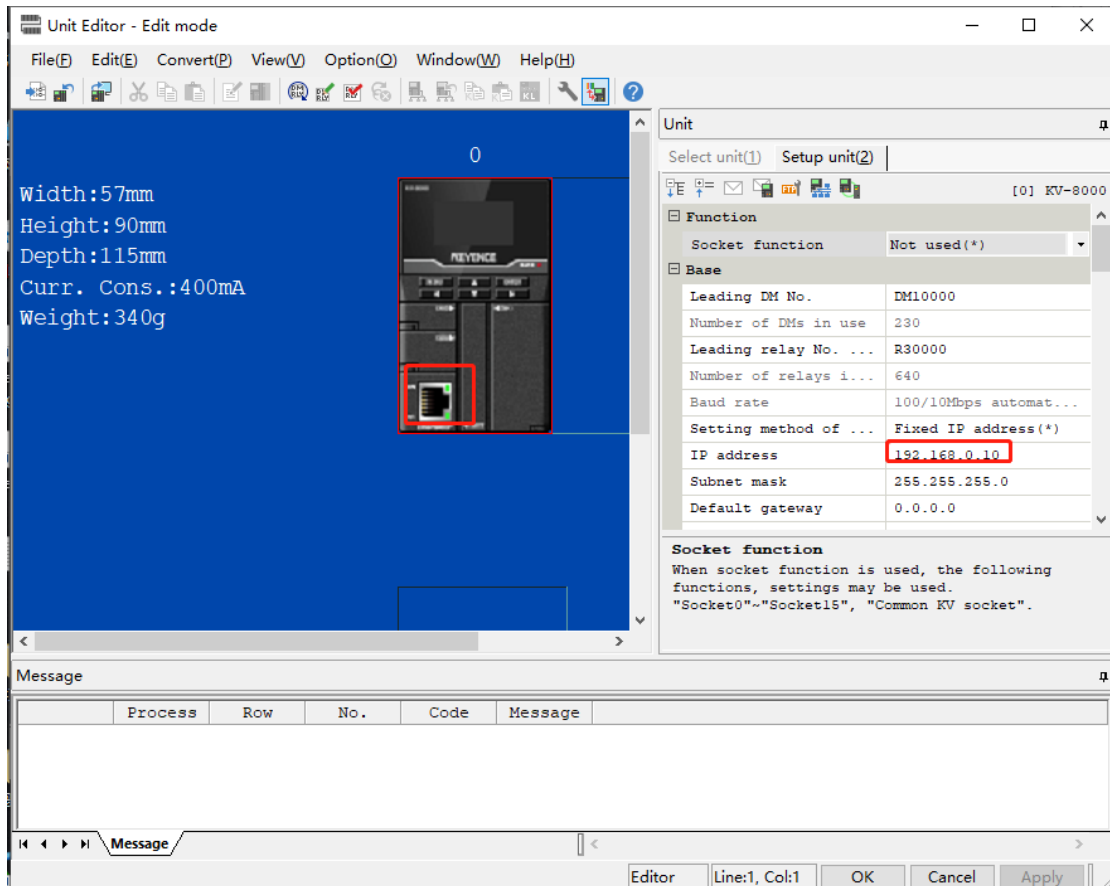

Click the shortcut key  to enter EtherNet/IP settings interface.

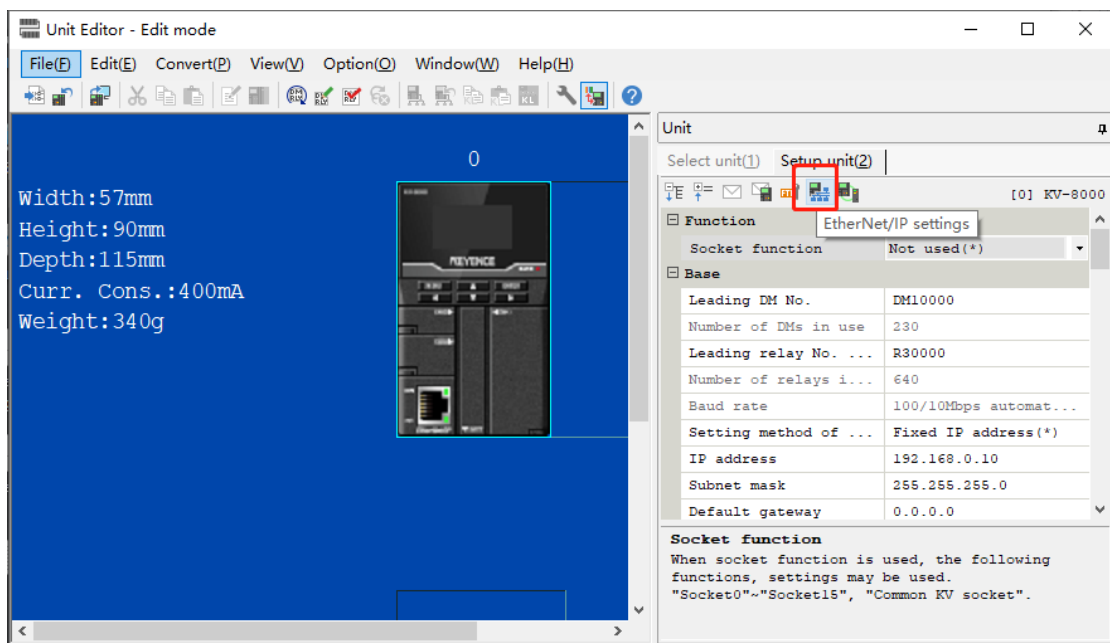

In the pop-up window, click Manual Configuration.

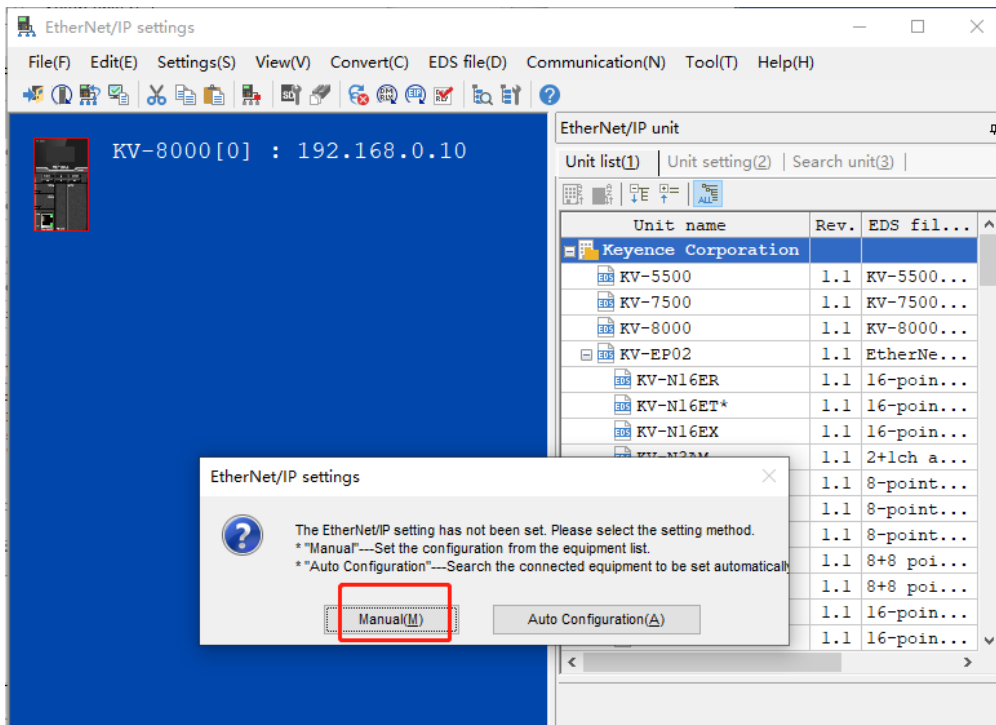

Install the EDS file of BN-8034 (V1.01 is a data-only EDS file). Click EDSfile-reg, select the EDS file, and click Open to complete the EDS file installation.

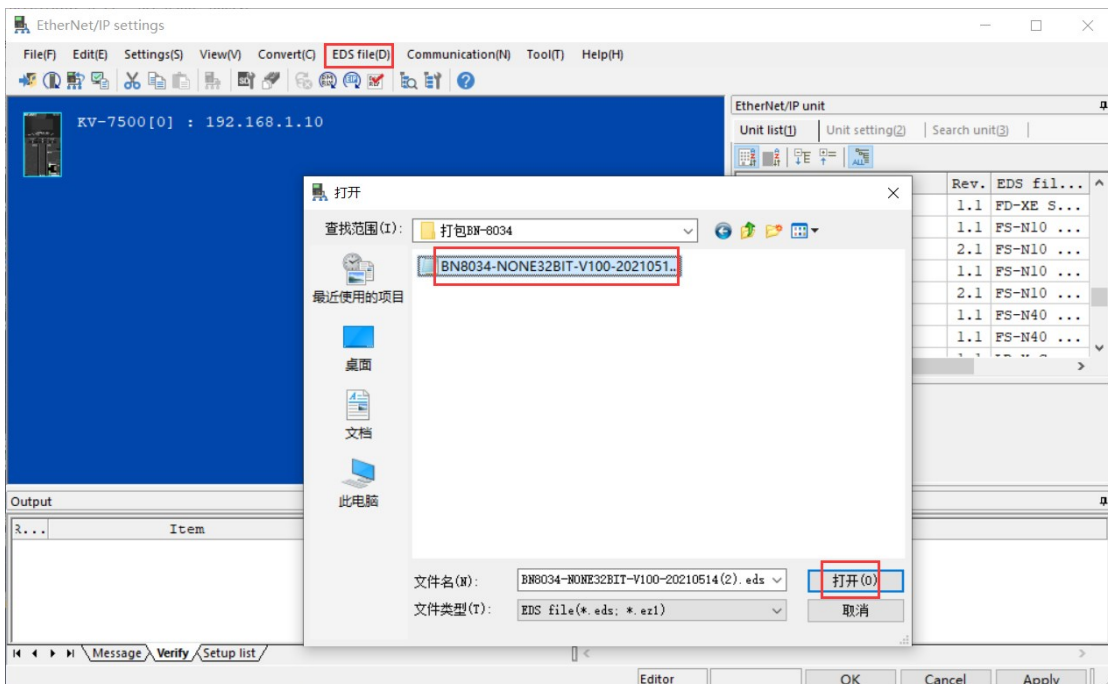

Find BN-8034 in the unit list, drag it to the KV8000 network, and fill in the BN-8034 node address and IP address. Click OK.

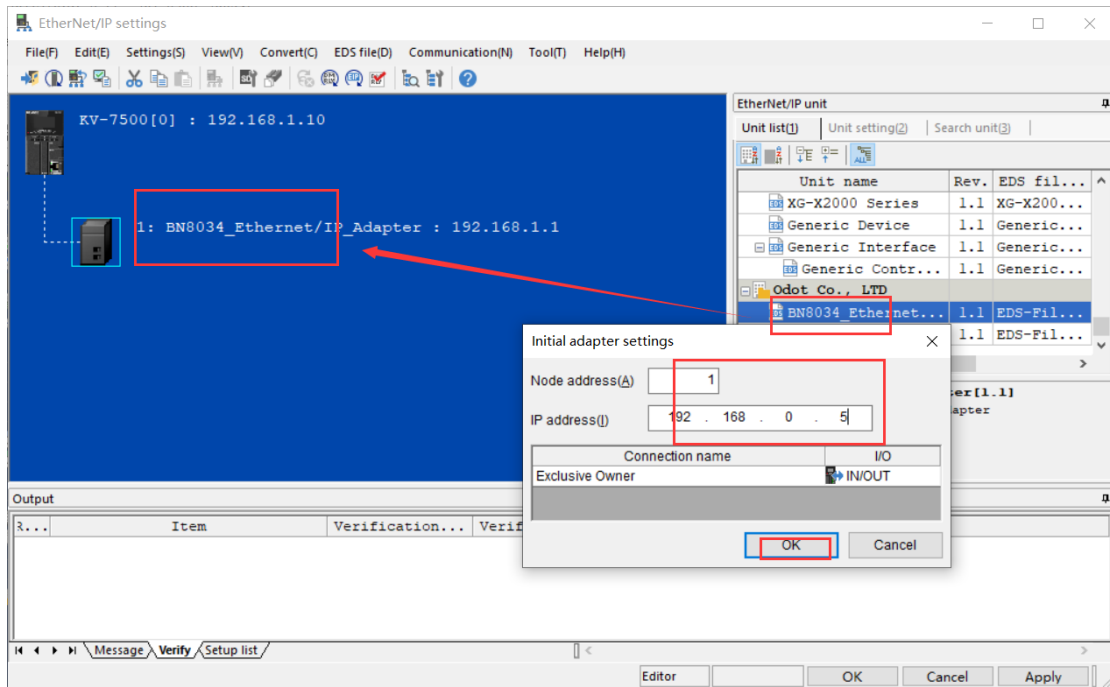

Then set the BN-8034 input and output word size. Click Exclusive Owner, click Set parameter in the pop-up window, and fill in the input and output word size in the pop-up window. Here fill in the output byte 8, enter the word into byte 17, and click OK.

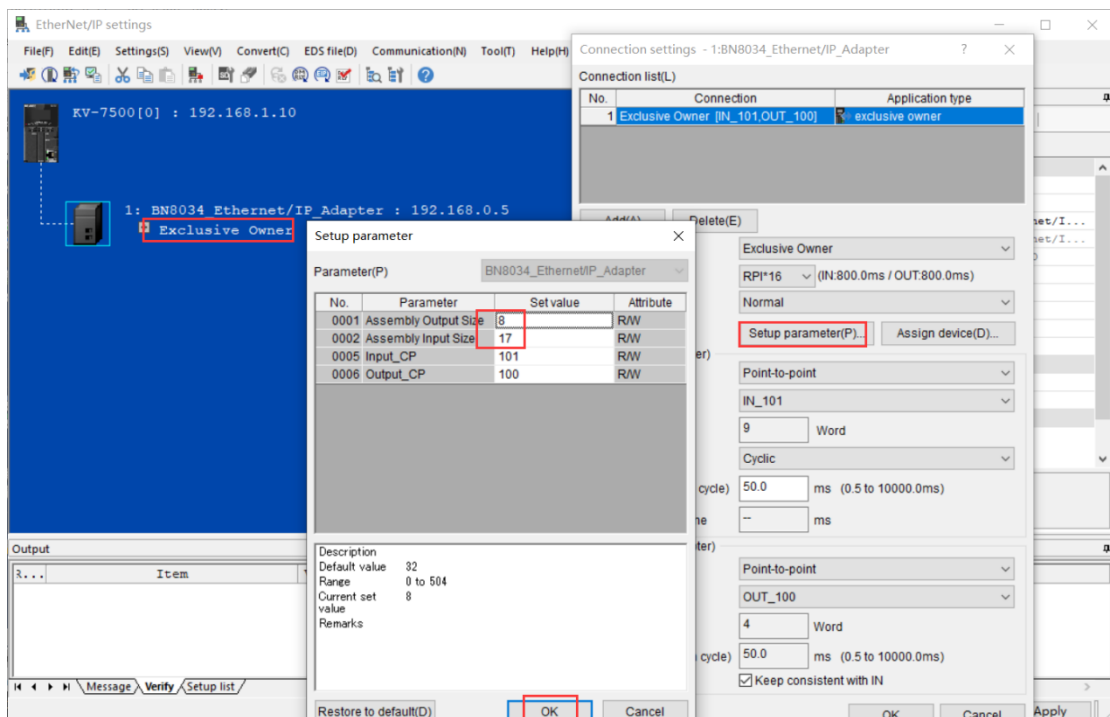

Click Assign device to view the data area address mapped by the IO module of the BN-8034.

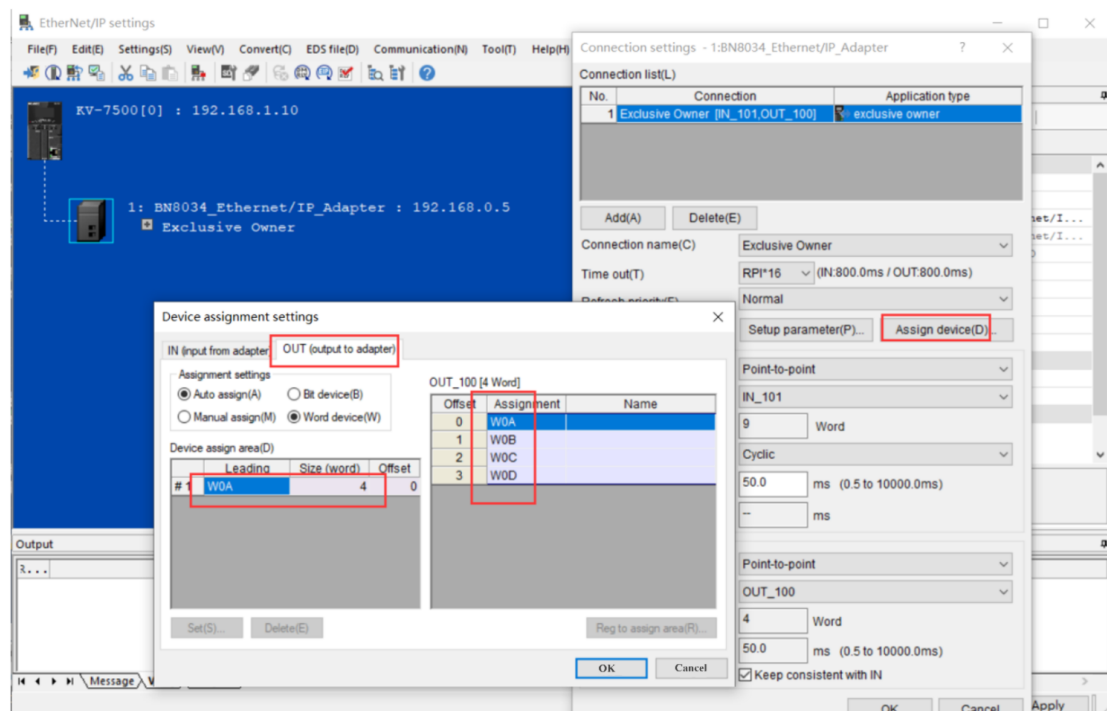
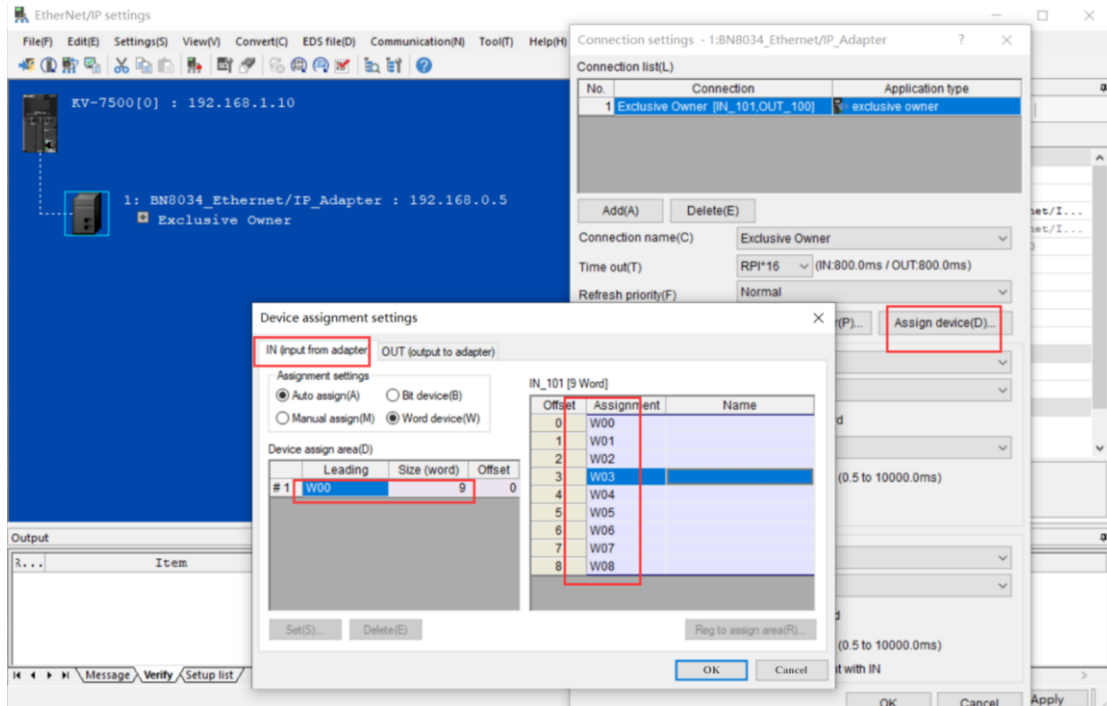

After the configuration is complete, click File-Apply to save the configuration. Close the window.

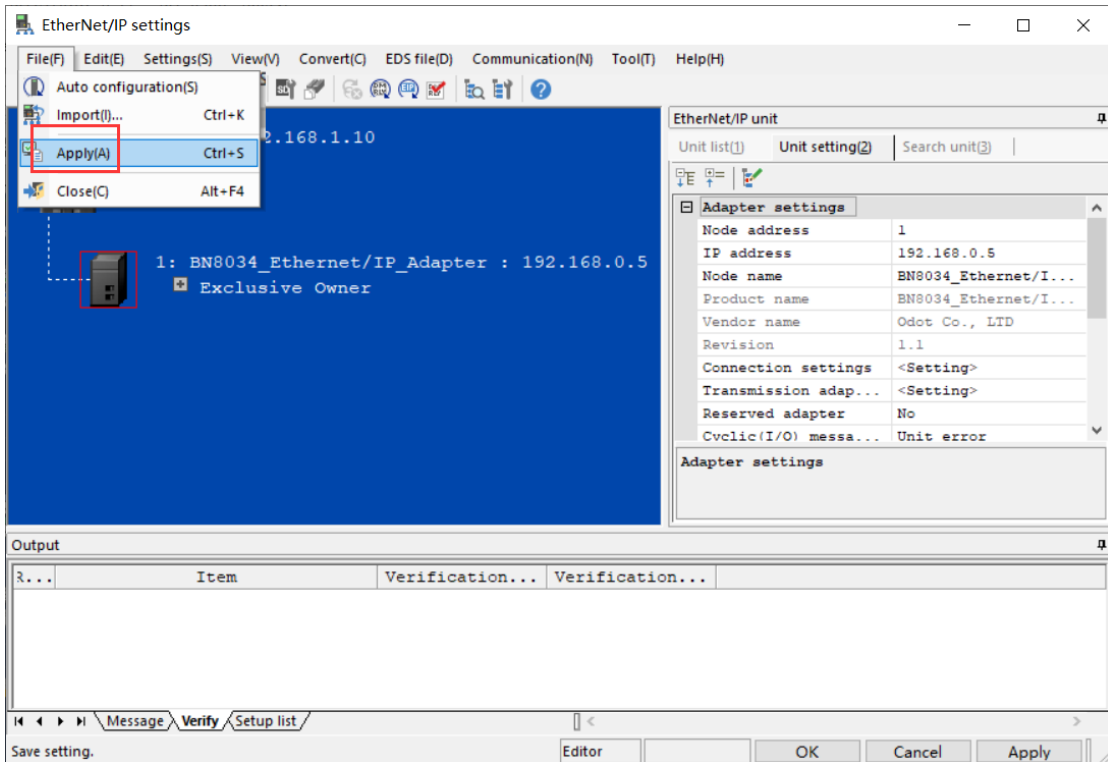

Go back to the cell editing window. Close the window and click Yes in the pop-up dialog box to save the changes.

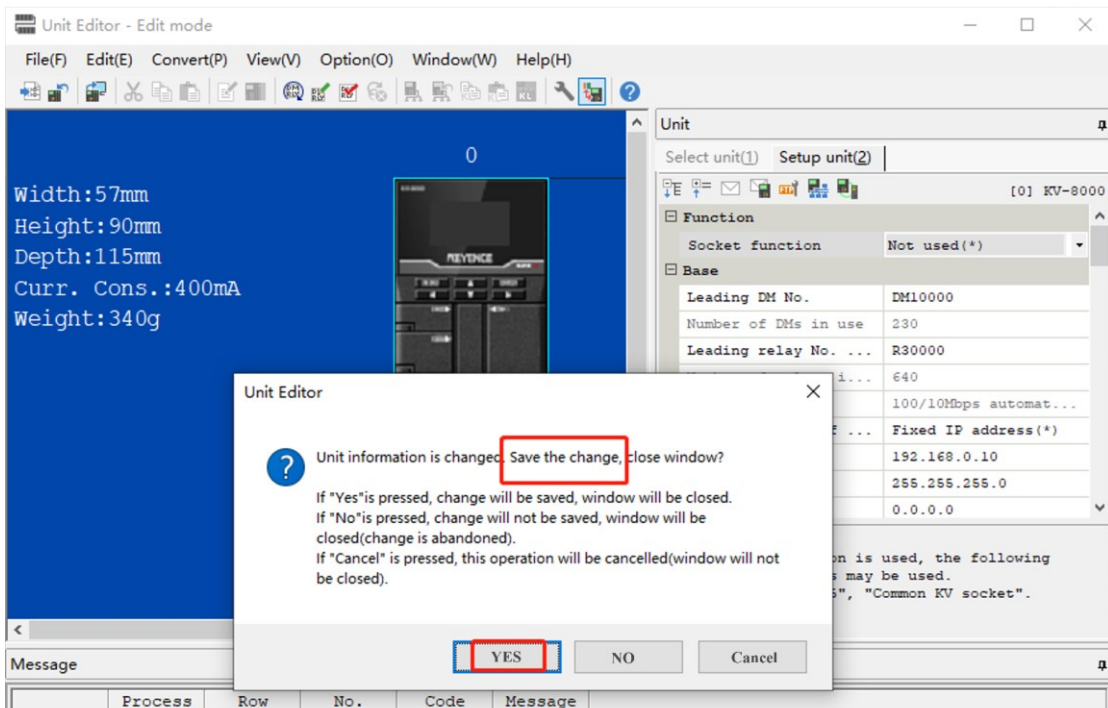

Go back to the KV STUDIO window, select the USB port, click the shortcut key  to transfer the program to the KV8000 PLC, click Execute in the pop-up window, and click Yes in the pop-up window. After the program is transferred, click to change the

PLC operation mode to RUN mode.

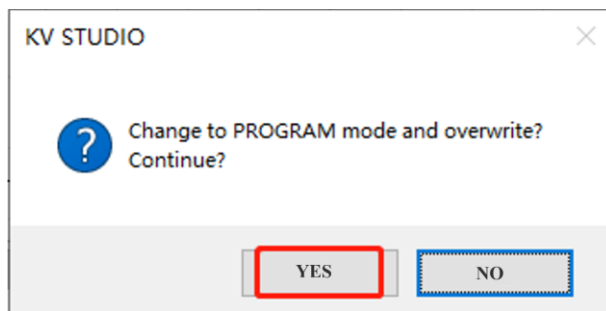
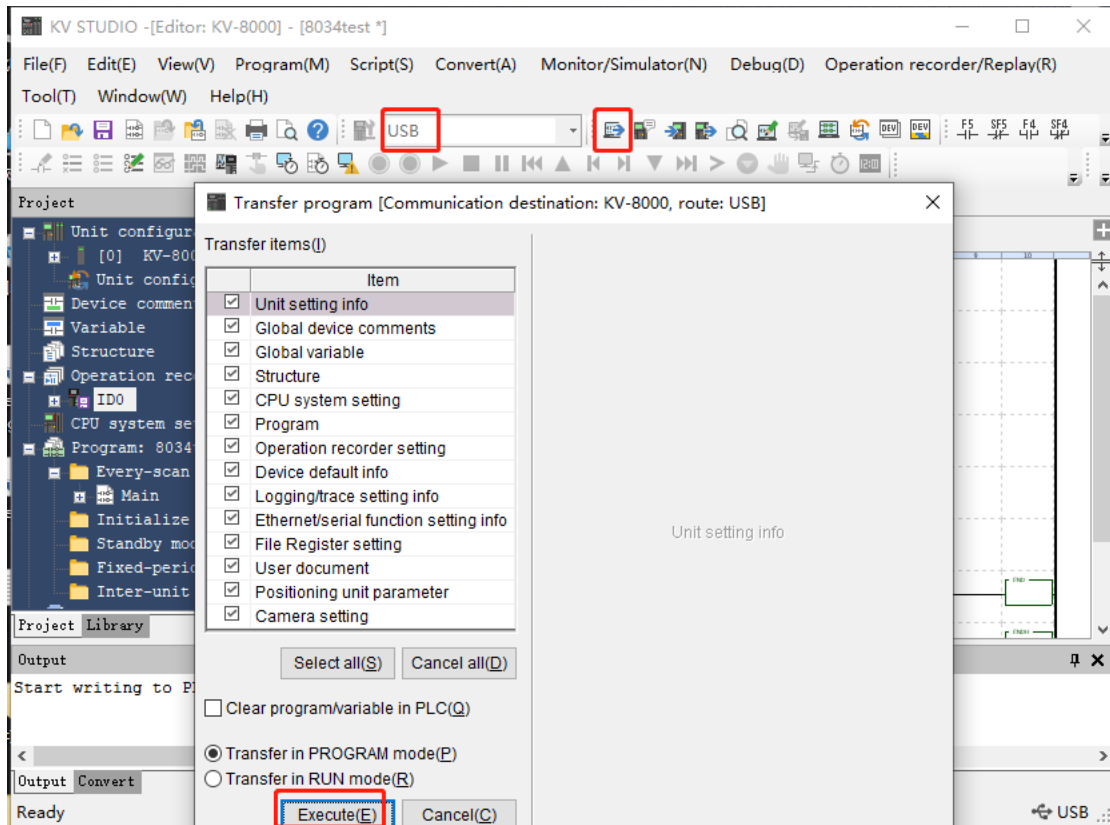

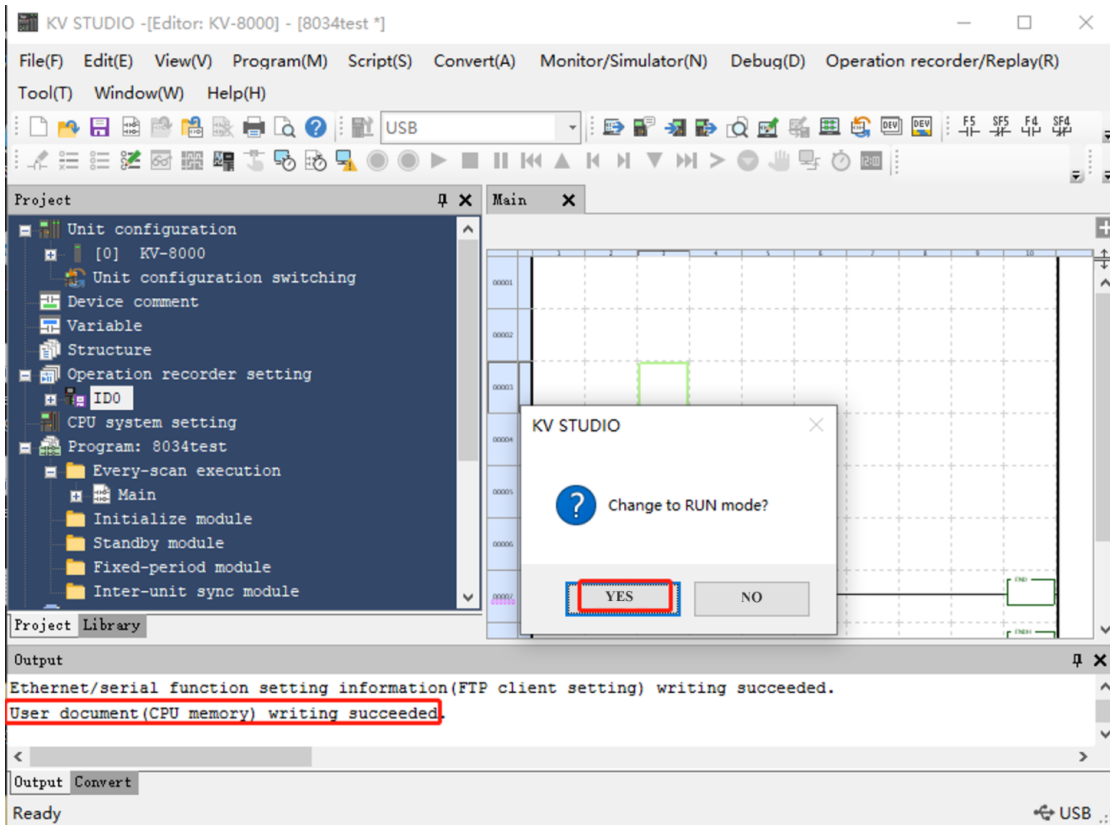

Click the drop-down menu of the project KV8000 and double-click the BN-8034 to pop up the I/O monitoring interface.

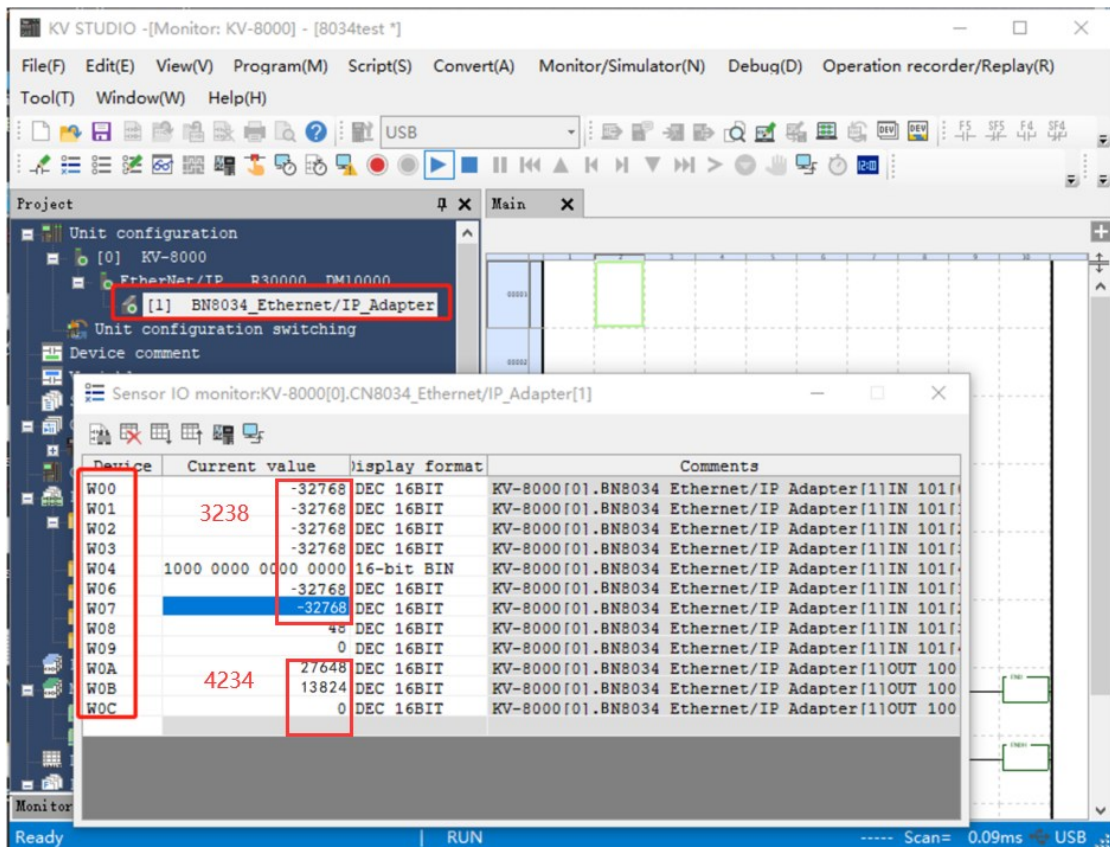

The comparison PLC address corresponds to the hardware module. W00-W07 are the input mapping address, and W0A-W0D are the output mapping address. The BT-4234 has input address W08 because the BT-4234 comes with input open circuit diagnostics.

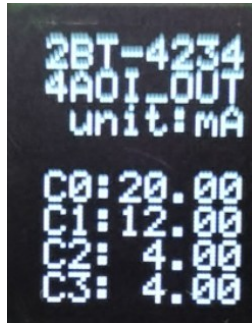

Example of communication between BT-5312 and BN-80XX

Example of communication between BT-5312 and BN-8031

BT-5312 is a serial port module, which can be used as a protocol converter with adapter BN-8031 module to realize Modbus RTU/ASCII to Modbus TCP, and the serial port supports master, slave, and free transparent transmission modes, similar to ODOT-S2E2/ ODOT-S4E2 gateway.

1 BT-5312 works in master mode

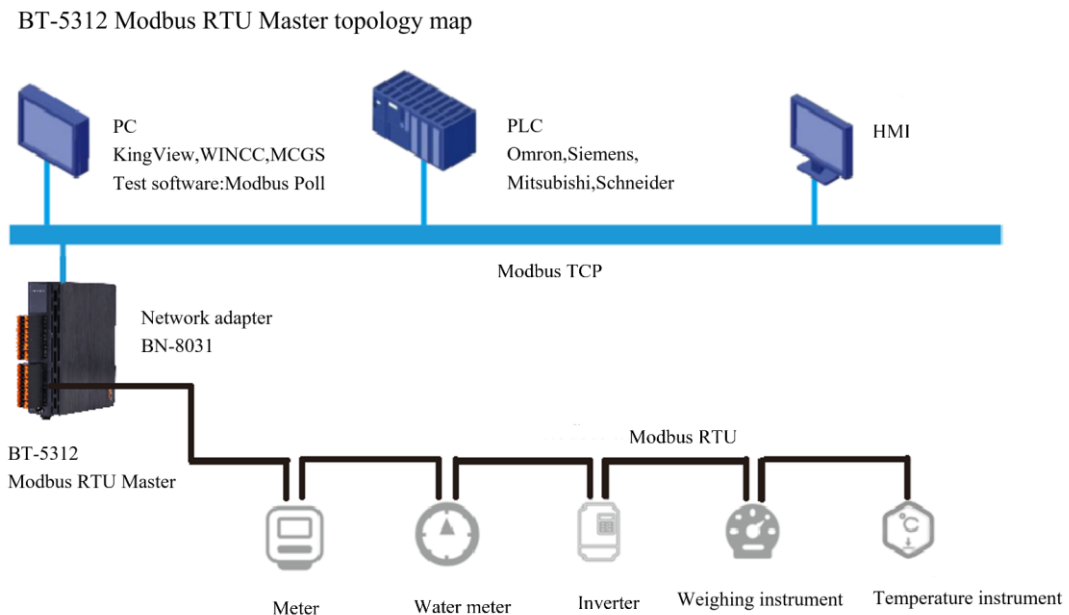

Note: 1. It needs to use IO Config to set parameters.

2. If not using the latest version of IO Config, it needs to update the device description file (hardware support package) or install the latest version of IO Config.

1. Configure the parameters of the BT-5312 module

Hardware Composition: BN-8031, BT-5312 with Siemens S7-1200

1. Power the BN-8031 module to 24VDC, and connect the network cable directly to the PC and BN-8031. BT-5312 wiring A1+ B1- connect to 485 to USB converter, USB serial port to PC. Provide 24VDC to the S7-1200 and BN-8031 modules

respectively, connect the network port of S7-1200 to Port2 of BN-8031, and connect Port1 of BN-8031 to PC for configuration. BT-5312 wiring A+B- to 485 to USB converter, USB serial port to PC.

2. Open the IO Config software, click Search Device, select the local network card, click Search Device, click Upload, and the project will be automatically generated.

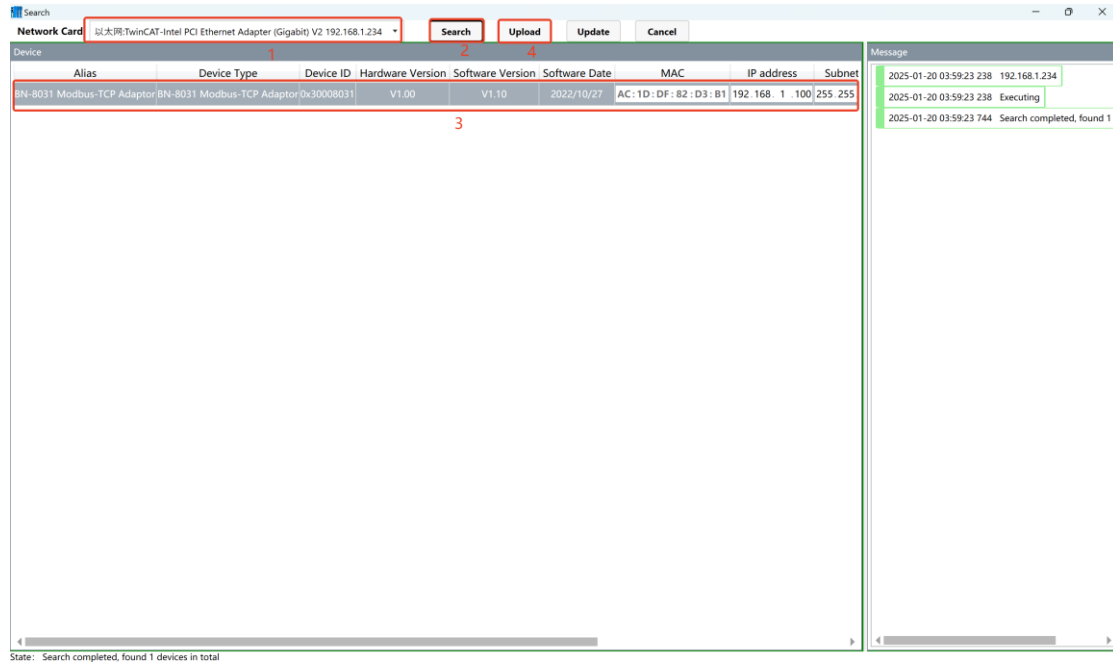

After uploading the module, it can configure the parameters of BT-5312, select the BT-5312 module, click Configure Parameters, and set the working mode of serial port 1: Modbus master, 9600bps, N, 8, 1, RTU.

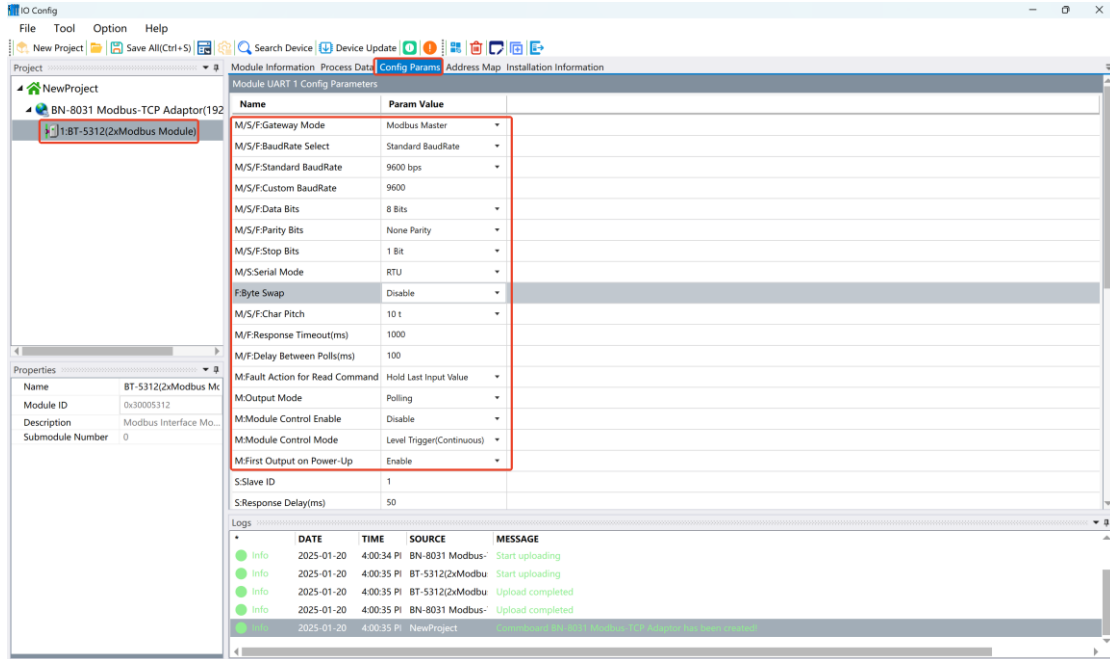

Right-click BT-5312, select Submodule Management, select the read and write command of the master mode in the pop-up window, and click OK. **Note: The M/S/F here represent the valid parameters of the master (M), slave (S), and free transparent transmission (F) modes, respectively.**

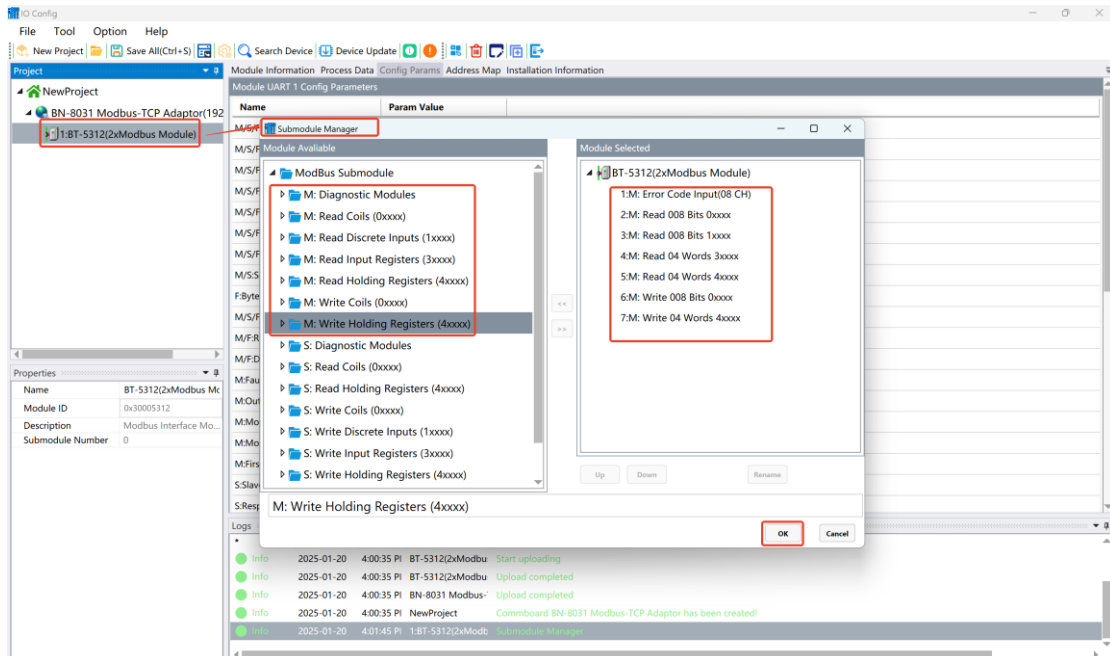

Select the read and write command and click Configure Parameters to set parameters such as slave ID number and start address.

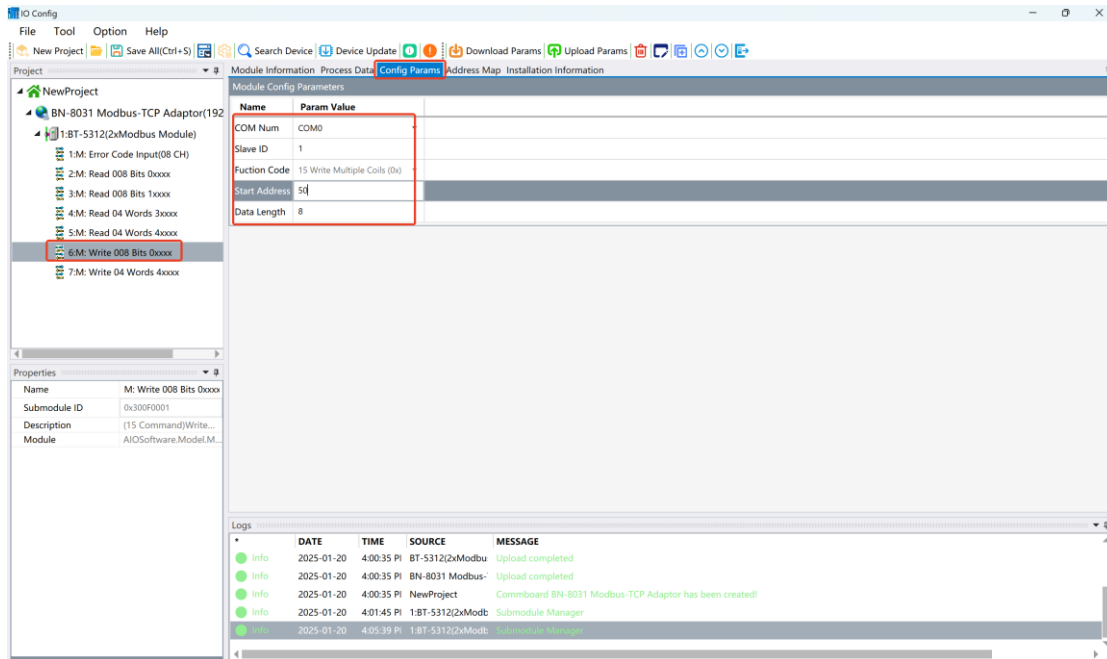

After all parameters are configured, right-click BN-8031 and select Download Configuration.

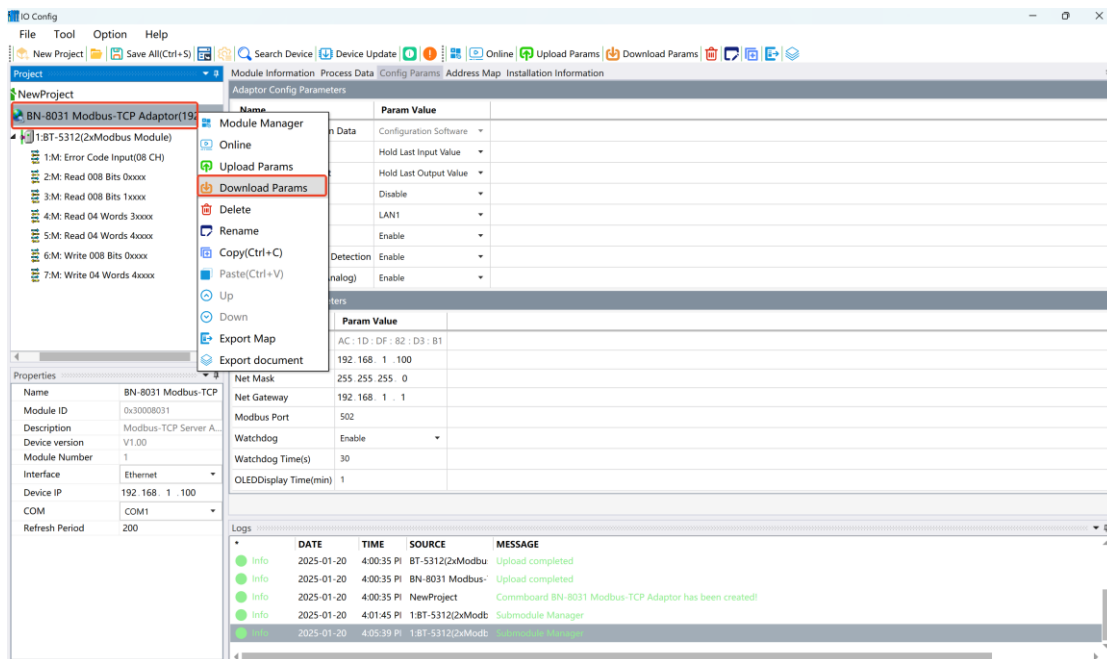

Select BN-8031 and click the address table to view the address mapping relationship.

The screenshot shows the 'IO Config' software interface. The main window is titled 'Address Map' and displays a table with the following columns: Name, Input Bit(1xxxx), Output Bit(0xxxx), Input Word(3xxxx), and Output Word(4xxx). The table is organized into sections for different modules:

- 1# BT-5312(2xModbus Module), 1# M: Error Code Input(08 CH):** Contains 8 rows of 'Input Data' from 1 to 8, with corresponding hexadecimal values in the 'Input Word' column.
- 1# BT-5312(2xModbus Module), 2# M: Read 008 Bits 0xxxx:** Contains 8 rows of 'Bit' from Bit0 to Bit7, with corresponding hexadecimal values in the 'Input Word' column.
- 1# BT-5312(2xModbus Module), 3# M: Read 008 Bits 1xxxx:** Contains 1 row of 'Bit0' with a corresponding hexadecimal value in the 'Input Word' column.

The left sidebar shows a tree view of the project structure, including 'NewProject', 'BN-8031 Modbus-TCP Adaptor(192.168)', and sub-modules like '1:BT-5312(2xModbus Module)'. The bottom section shows a log of system events:

DATE	TIME	SOURCE	MESSAGE
2025-01-20	4:00:35 PM	BT-5312(2xModbu	Upload completed
2025-01-20	4:00:35 PM	BN-8031 Modbus-	Upload completed
2025-01-20	4:00:35 PM	NewProject	Commboard BN-8031 Modbus-TCP Adaptor has been created!
2025-01-20	4:01:45 PM	1:BT-5312(2xModb	Submodule Manager
2025-01-20	4:02:39 PM	1:BT-5312(2xModb	Submodule Manager

2. TIA V16 collects data

Open the TIA V16 software and click Create to create the new project "BN8031-BT5312".

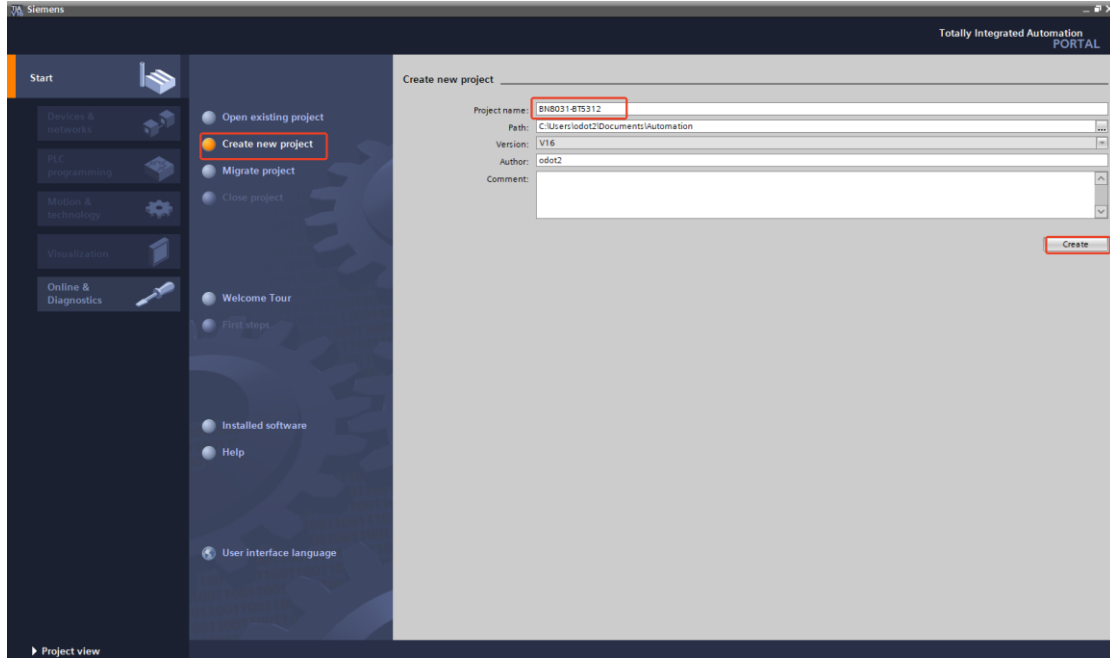

Click Add Device and select “CPU 1214 DC/DC/DC 6ES7 214-1AG40-0XB0”, click OK.

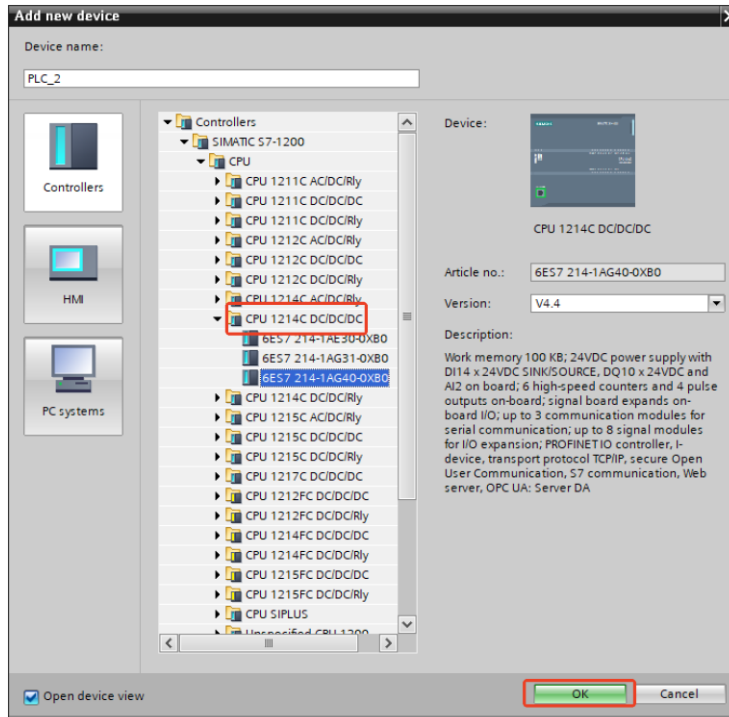

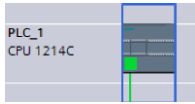

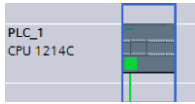
Click , select the Ethernet addresses, set the IP address as 192.168.1.10, add a new subnet PN/IE_1.

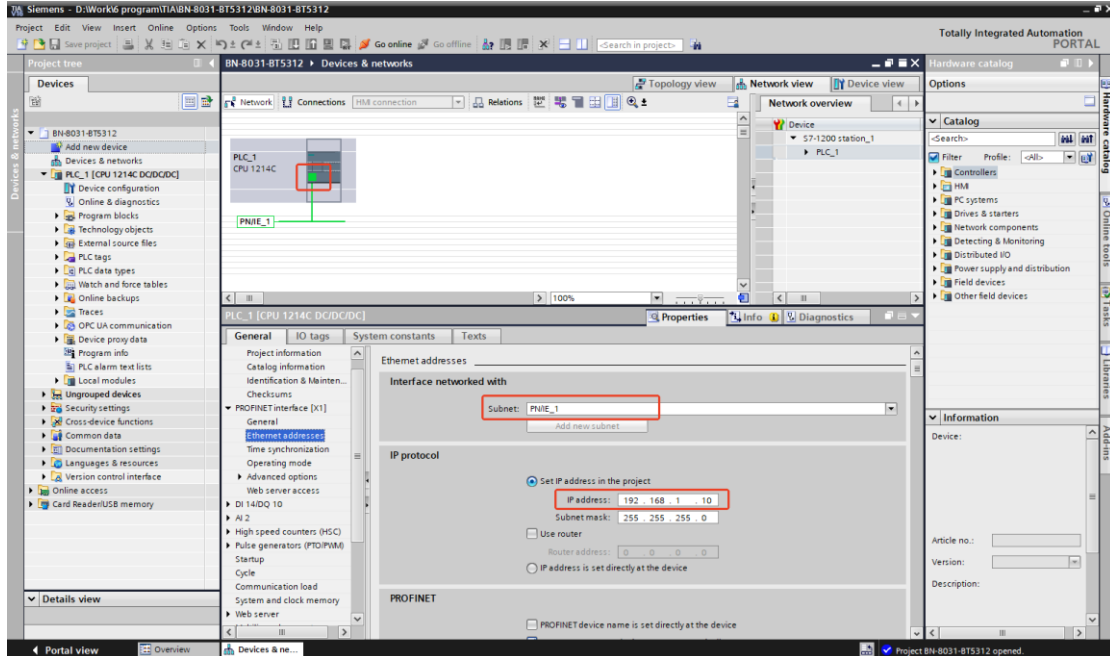

Add a new block from the Block drop-down menu and add data blocks DB1, DB2, DB3, DB4, and DB5. DB1 is used for S7-1200 to establish a connection with BN-8031, DB2 is used to store 1xxxx data, DB3 is used to store 3xxxx data, DB4 is used to store 0xxxx data, and DB5 is used to store 4xxxx data. (IP of BN-8031: 192.168.1.100), the IP address of the module can be viewed and modified through IO Config software).

Siemens - D:\Work6 program\TIA\BN-8031-8T5312\BN-8031-8T5312

Project tree: BN-8031-8T5312 > PLC_1 [CPU 1214C DGD/GDC] > Program blocks > Data block-1 [DB1]

Options: Find and replace, Languages & resources

Name	Data type	Offset	Start value	Retain	Accessible f...	Write...	Visible in...	Setpoint	Comment
Static									
TCP-1									
Interfaceid	TCON_IP_V4	0.0	64						HWIdentifier of IE-interfa...
ID	CONM_DUC	2.0	1						type of connection: 11=...
ConnectionType	Byte	4.0	16#0B						active/passive connecti...
ActiveEstablished	Bool	5.0	1						remote IP address (IPv4)
RemoteAddress	IP_V4	6.0							remote UDP/TCP port num...
RemotePort	UInt	10.0	502						local UDP/TCP port num...
LocalPort	UInt	12.0	0						
TCP-2									
Interfaceid	TCON_IP_V4	14.0	64						HWIdentifier of IE-interfa...
ID	CONM_DUC	16.0	2						type of connection: 11=...
ConnectionType	Byte	18.0	16#0B						active/passive connecti...
ActiveEstablished	Bool	19.0	1						remote IP address (IPv4)
RemoteAddress	IP_V4	20.0							remote UDP/TCP port num...
RemotePort	UInt	24.0	502						local UDP/TCP port num...
LocalPort	UInt	26.0	0						
TCP-3									
Interfaceid	TCON_IP_V4	28.0							
LocalPort	TCON_IP_V4	42.0							

Compiling finished (errors: 0; warnings: 0)

Siemens - D:\Work6 program\TIA\BN-8031-8T5312\BN-8031-8T5312

Project tree: BN-8031-8T5312 > PLC_1 [CPU 1214C DGD/GDC] > Program blocks > Data block-2 [DB2]

Options: Find and replace, Languages & resources

Name	Data type	Offset	Start value	Retain	Accessible f...	Write...	Visible in...	Setpoint	Comment
Static									
8031-1xxx	Array(0..15) ...	0.0	false						
8031-1xxx0[0]	Bool	0.0	false						
8031-1xxx0[1]	Bool	0.1	false						
8031-1xxx0[2]	Bool	0.2	false						
8031-1xxx0[3]	Bool	0.3	false						
8031-1xxx0[4]	Bool	0.4	false						
8031-1xxx0[5]	Bool	0.5	false						
8031-1xxx0[6]	Bool	0.6	false						
8031-1xxx0[7]	Bool	0.7	false						
8031-1xxx0[8]	Bool	1.0	false						
8031-1xxx0[9]	Bool	1.1	false						
8031-1xxx0[10]	Bool	1.2	false						
8031-1xxx0[11]	Bool	1.4	false						
8031-1xxx0[12]	Bool	1.4	false						
8031-1xxx0[13]	Bool	1.5	false						
8031-1xxx0[14]	Bool	1.6	false						
8031-1xxx0[15]	Bool	1.7	false						

Compiling finished (errors: 0; warnings: 0)

Siemens - D:\Work6 program\TIA\BN-8031-8T5312\BN-8031-8T5312

Project tree: BN-8031-8T5312 > PLC_1 [CPU 1214C DGD/GDC] > Program blocks > Data block-3 [DB3]

Data block-3

Name	Data type	Offset	Start value	Retain	Accessible f...	Write...	Visible in...	Setpoint	Comment
8031-3xxxx	Array(0..15) of Word	0.0							
8031-3xxxx[0]	Word	0.0	16#0						
8031-3xxxx[1]	Word	2.0	16#0						
8031-3xxxx[2]	Word	4.0	16#0						
8031-3xxxx[3]	Word	6.0	16#0						
8031-3xxxx[4]	Word	8.0	16#0						
8031-3xxxx[5]	Word	10.0	16#0						
8031-3xxxx[6]	Word	12.0	16#0						
8031-3xxxx[7]	Word	14.0	16#0						
8031-3xxxx[8]	Word	16.0	16#0						
8031-3xxxx[9]	Word	18.0	16#0						
8031-3xxxx[10]	Word	20.0	16#0						
8031-3xxxx[11]	Word	22.0	16#0						
8031-3xxxx[12]	Word	24.0	16#0						
8031-3xxxx[13]	Word	26.0	16#0						
8031-3xxxx[14]	Word	28.0	16#0						
8031-3xxxx[15]	Word	30.0	16#0						

Compiling finished (errors: 0; warnings: 0)

Path: Program blocks | Description: Data block-1 (DB1) | Errors: 0 | Warnings: 0 | Time: 9:30:37 AM

Siemens - D:\Work6 program\TIA\BN-8031-8T5312\BN-8031-8T5312

Project tree: BN-8031-8T5312 > PLC_1 [CPU 1214C DGD/GDC] > Program blocks > Data block-4 [DB4]

Data block-4

Name	Data type	Offset	Start value	Retain	Accessible f...	Write...	Visible in...	Setpoint	Comment
8031-0xxxx	Array(0..7) of Bool	0.0							
8031-0xxxx[0]	Bool	0.0	false						
8031-0xxxx[1]	Bool	0.1	false						
8031-0xxxx[2]	Bool	0.2	false						
8031-0xxxx[3]	Bool	0.3	false						
8031-0xxxx[4]	Bool	0.4	false						
8031-0xxxx[5]	Bool	0.5	false						
8031-0xxxx[6]	Bool	0.6	false						
8031-0xxxx[7]	Bool	0.7	false						

Compiling finished (errors: 0; warnings: 0)

Path: Program blocks | Description: Data block-1 (DB1) | Errors: 0 | Warnings: 0 | Time: 9:30:37 AM

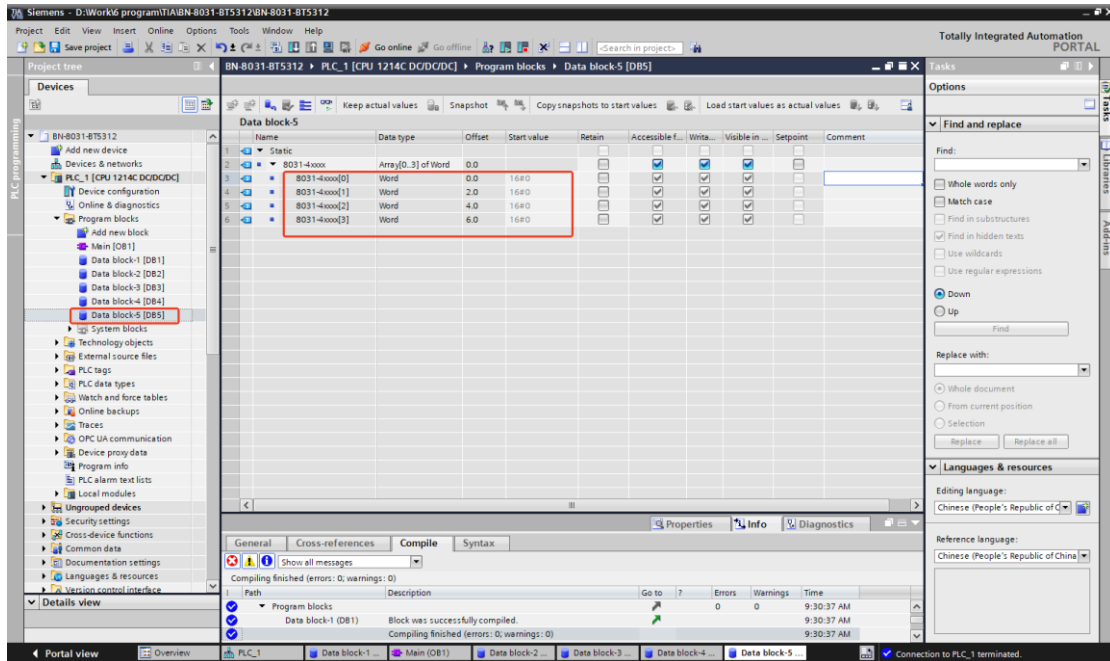

After a new block is created, each block needs to be compiled. Note: DB1, DB2, DB3, DB4, and DB5 right-click attributes, and remove the ✓ before accessing the optimized block.

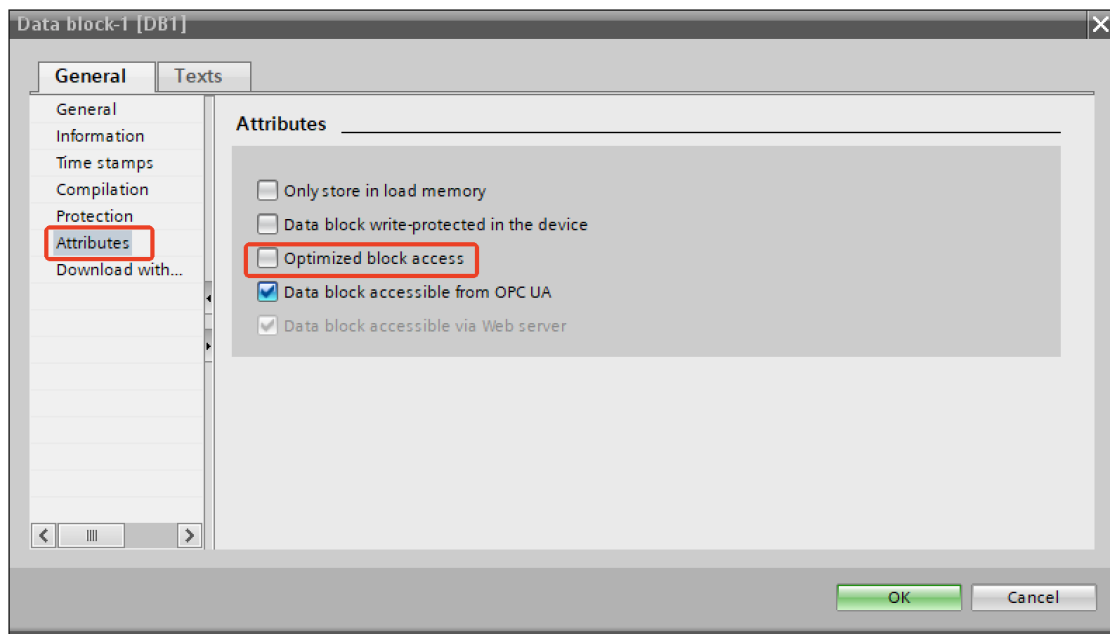

4. In the program block drop-down menu, double-click Mian [OB1], find the command on the right MB_CLIENT drag it to program section 1. Modify the parameters as shown in the figure.

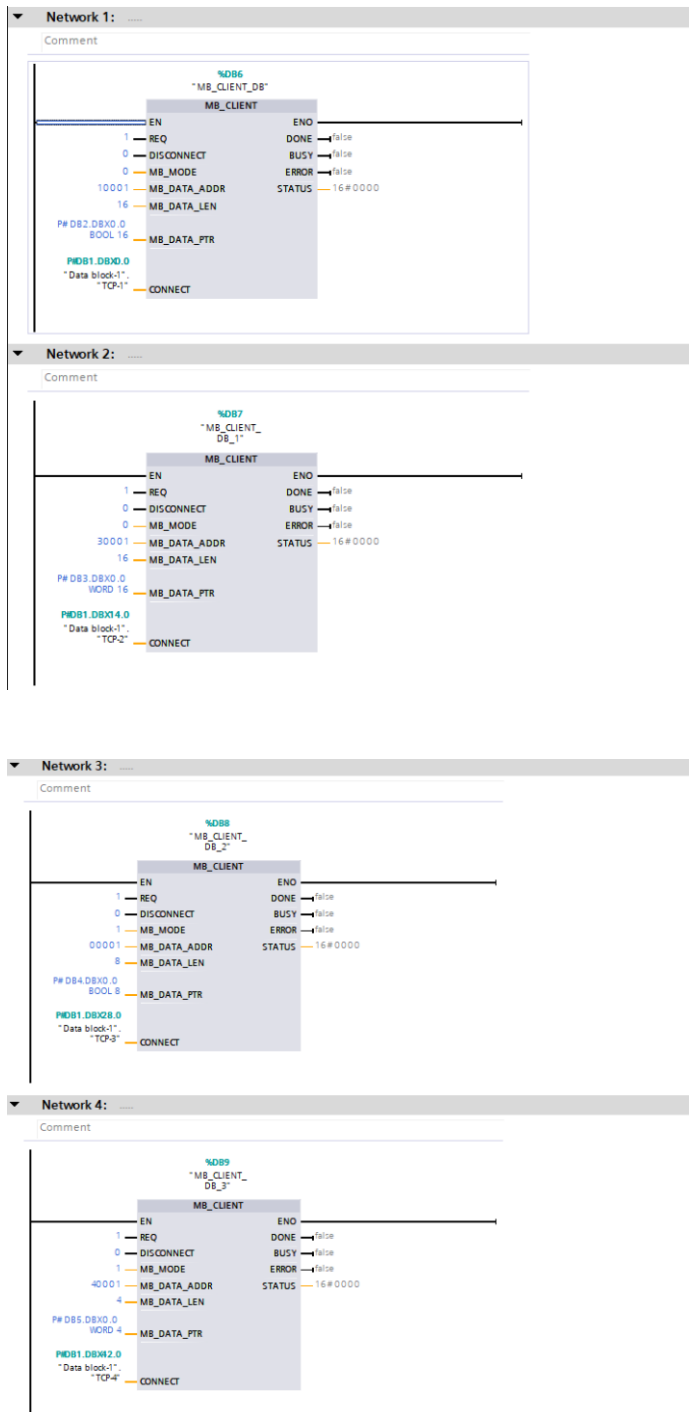

5. After the setting is completed, save, compile, download, and go online after the download is completed.

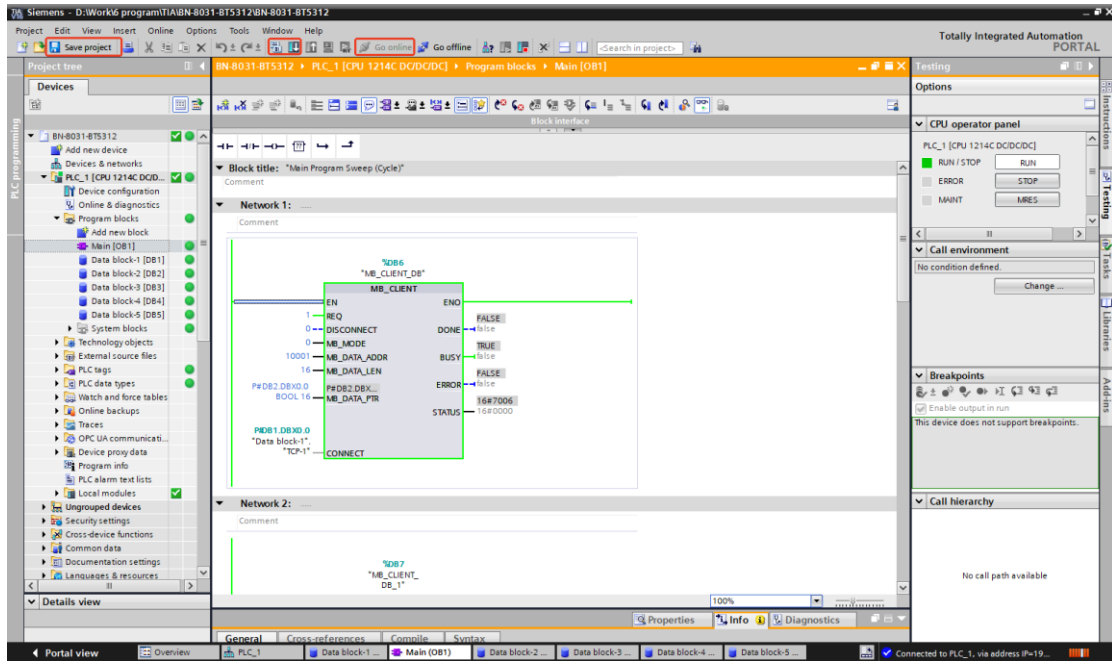

The Modbus Slave software is used to emulate the RS485 slave device on serial port 1, and a new monitoring table can be added to monitor the field device values online on the monitoring table.

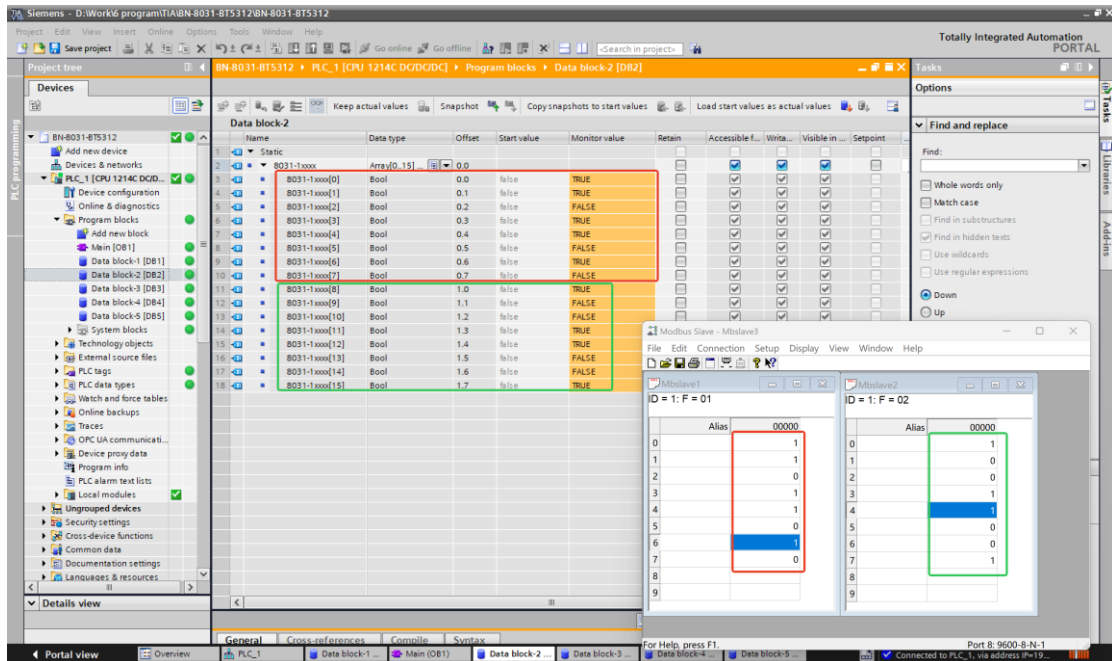

Siemens - D:\Work6 program\TIA\BN-8031-BT5312\BN-8031-BT5312

Totally Integrated Automation PORTAL

Project tree: BN-8031-BT5312 > PLC_1 [CPU 1214C DC/DIGDC] > Program blocks > Data block 3 [DB3]

Devices: BN-8031-BT5312

Data block 3

Name	Data type	Offset	Start value	Monitor value	Retain	Accessible f...	Write...	Visible in...	Setpoint
1	Static								
2	8031-3xxx[0]	Word	0.0	16#0					
3	8031-3xxx[1]	Word	2.0	16#0000					
4	8031-3xxx[2]	Word	4.0	16#0000					
5	8031-3xxx[3]	Word	6.0	16#0000					
6	8031-3xxx[4]	Word	8.0	16#0000					
7	8031-3xxx[5]	Word	10.0	16#0000					
8	8031-3xxx[6]	Word	12.0	16#0000					
9	8031-3xxx[7]	Word	14.0	16#0000					
10	8031-3xxx[8]	Word	16.0	16#0200					
11	8031-3xxx[9]	Word	18.0	16#0000					
12	8031-3xxx[10]	Word	20.0	16#013E					
13	8031-3xxx[11]	Word	22.0	16#0356					
14	8031-3xxx[12]	Word	24.0	16#0014					
15	8031-3xxx[13]	Word	26.0	16#0000					
16	8031-3xxx[14]	Word	28.0	16#0278					
17	8031-3xxx[15]	Word	30.0	16#0281					

Modbus Slave - Mbslave3

Modbus Slave - Mbslave4

Modbus Slave - Mbslave5

Modbus Slave - Mbslave6

Siemens - D:\Work6 program\TIA\BN-8031-BT5312\BN-8031-BT5312

Totally Integrated Automation PORTAL

Project tree: BN-8031-BT5312 > PLC_1 [CPU 1214C DC/DIGDC] > Watch and force tables > Watch table 1

Devices: BN-8031-BT5312

Watch table 1

Name	Address	Display format	Monitor value	Modify value	Comment	Tag c...
1	"Data block-4"-78... %DB4.DBX0.0	Bool	TRUE			
2	"Data block-4"-78... %DB4.DBX0.1	Bool	FALSE			
3	"Data block-4"-78... %DB4.DBX0.2	Bool	TRUE			
4	"Data block-4"-78... %DB4.DBX0.3	Bool	FALSE			
5	"Data block-4"-78... %DB4.DBX0.4	Bool	TRUE			
6	"Data block-4"-78... %DB4.DBX0.5	Bool	TRUE			
7	"Data block-4"-78... %DB4.DBX0.6	Bool	FALSE			
8	"Data block-4"-78... %DB4.DBX0.7	Bool	TRUE			

Modbus Slave - Mbslave5

Modbus Slave - Mbslave6

The screenshot displays the Siemens SIMATIC Manager interface. The main window shows a 'Watch and force tables' configuration for a Modbus Slave. The table lists the following data:

Name	Address	Display format	Monitor value	Modify value	Comment	Tag c...
"Data block-5" B...	%OB5.DBW0	Hex	16#0456			
"Data block-5" B...	%OB5.DBW2	Hex	16#0781			
"Data block-5" B...	%OB5.DBW4	Hex	16#0325			
"Data block-5" B...	%OB5.DBW6	Hex	16#0124			
	%add new...					

An overlaid dialog box titled 'Modbus Slave - Mbslave6' shows a table with the following data:

Alias	Value
	00050
0	0x0456
1	0x0781
2	0x0325
3	0x0124
4	
5	
6	
7	
8	
9	

The status bar at the bottom indicates 'Connected to PLC_1, via address IP=19...'.

2 BT-5312 works in slave mode

BT-5312 Modbus RTU Slave topology map

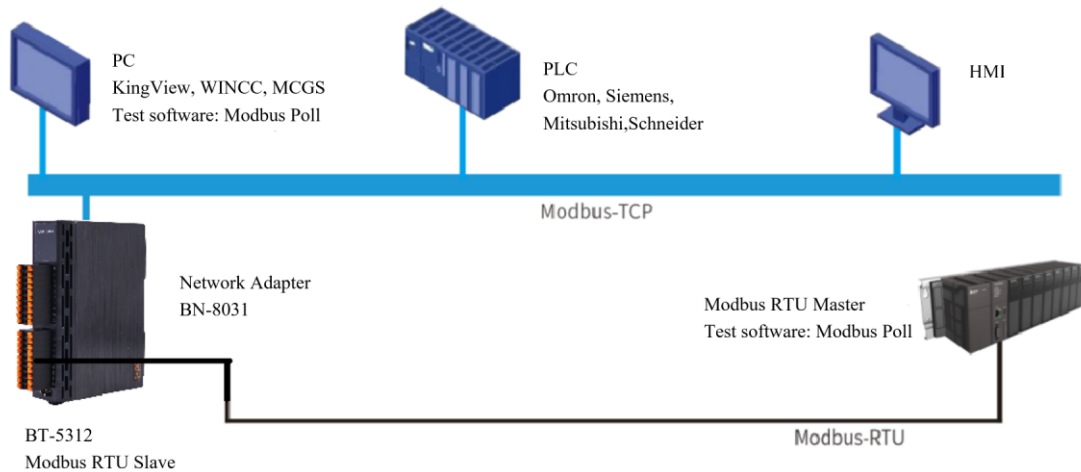

Note: 1. It needs to use IO Config to set parameters.

2. If not using the latest version of IO Config, it needs to update the device description file (hardware support package) or install the latest version of IO Config.

1. Configure the parameters of the BT-5312 module.

Hardware Composition: BN-8031, BT-5312 with Siemens S7-1200

Power the BN-8031 module to 24VDC, and connect the network cable directly to the PC and BN-8031. BT-5312 wiring A1+ B1 - connect to 485 to USB converter, USB serial port to PC. Provide 24VDC to the S7-1200 and BN-8031 modules respectively, connect the network port of S7-1200 to Port2 of BN-8031, and connect Port1 of BN-8031 to PC for configuration. BT-5312 wiring A+B- to 485 to USB converter, USB serial port to PC.

Open the IO Config software, click Search Device, select the local network card, click Search Device, click Upload, and automatically generate the project.

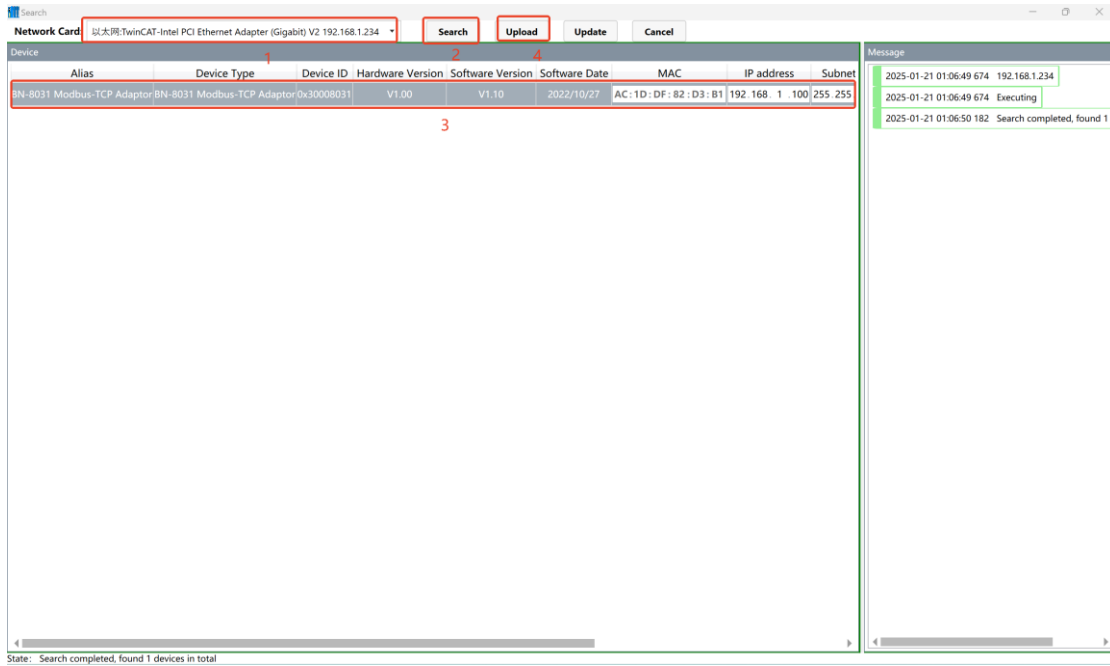

After uploading the module, it can configure the parameters of BT-5312, select the BT-5312 module, click Configure Parameters, and set the working mode of serial port 1: Modbus slave, 9600bps, N, 8, 1, RTU, slave ID number 1.

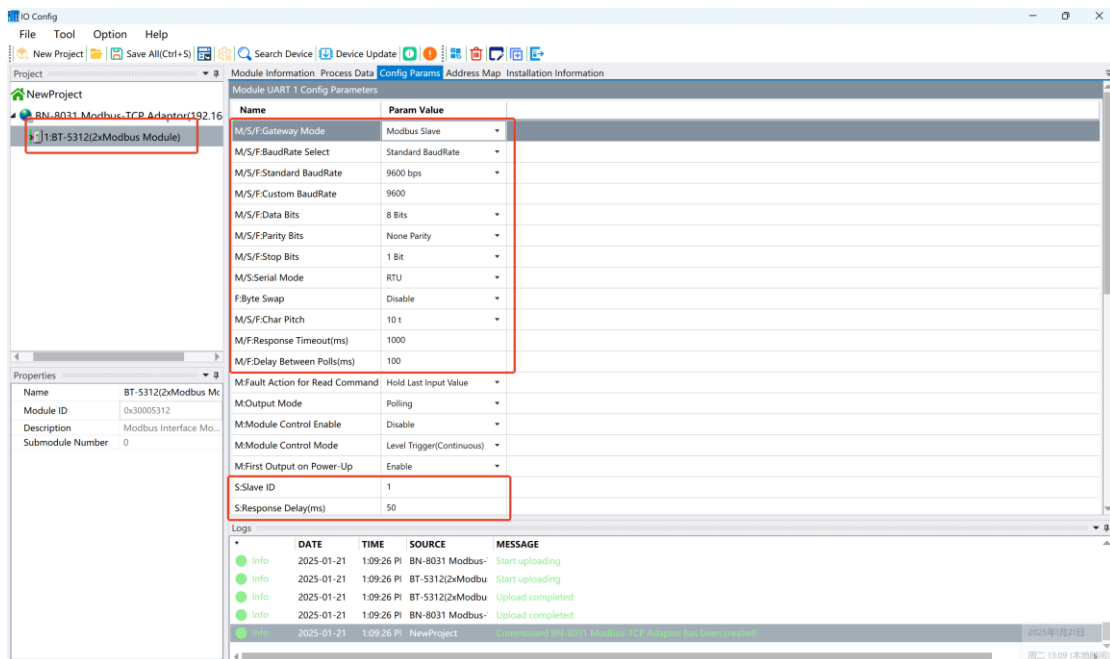

Right-click BT-5312, select Submodule Management, select the read and write command of the master mode in the pop-up window, and click OK. **Note: The M/S/F here represent the valid parameters of the master (M), slave (S), and free transparent transmission (F) modes, respectively.**

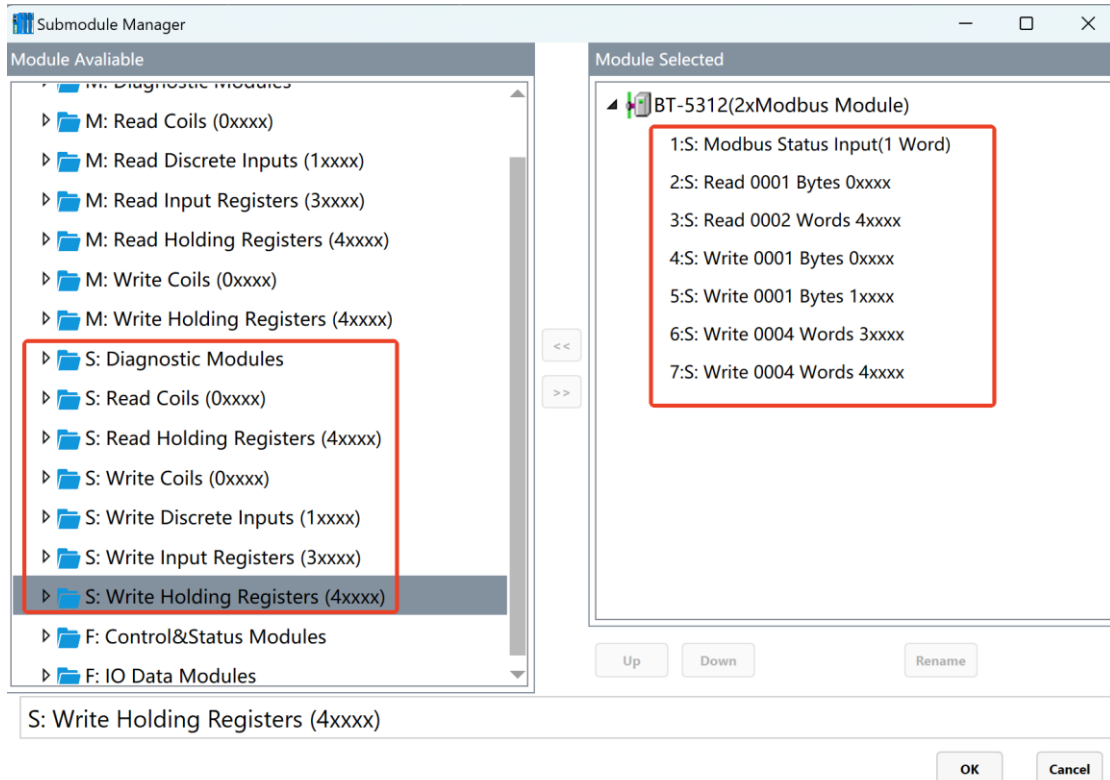

Select the read and write command and click Config Params to set parameters such as COM number and start address.

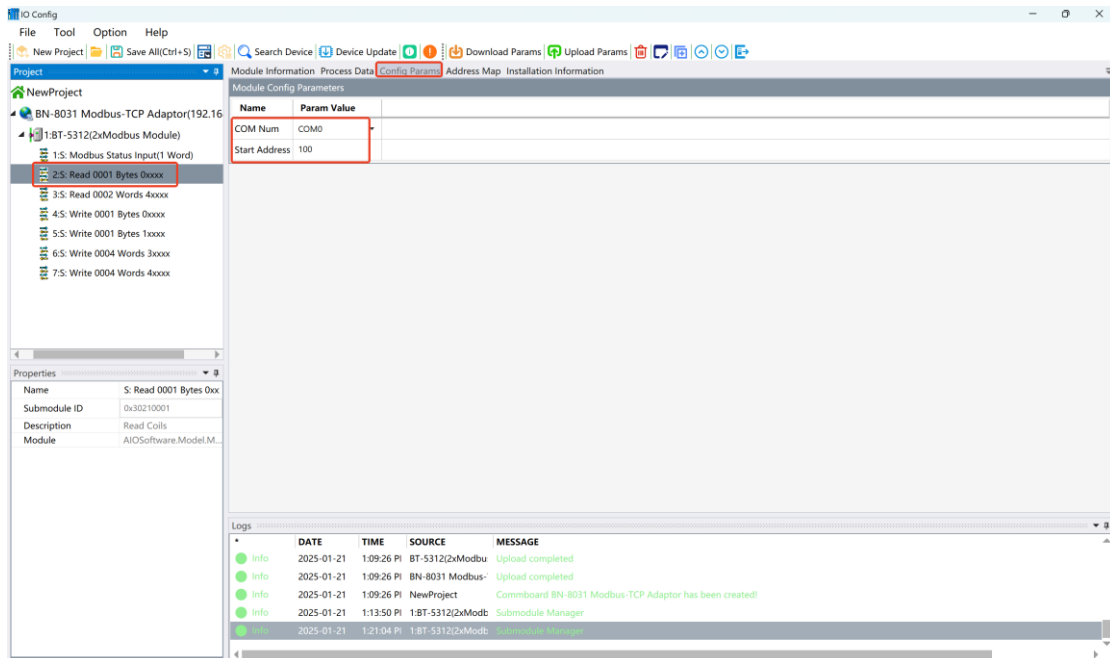

After all parameters are configured, right-click BN-8031 and select Download Params.

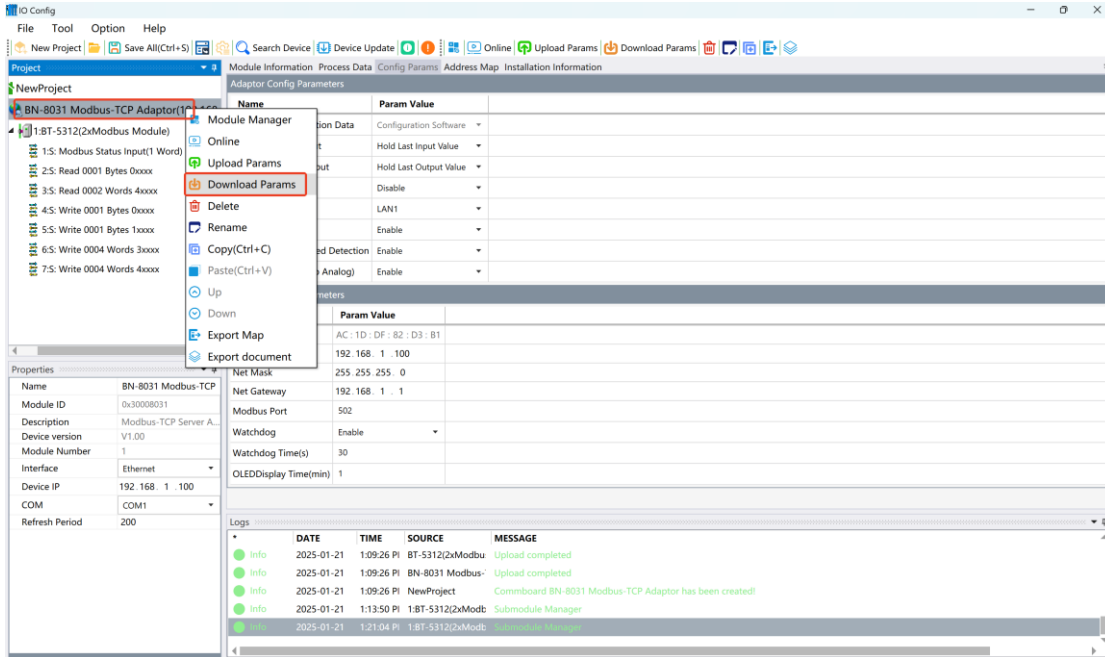

Select BN-8031 and click the address table to view the address mapping relationship.

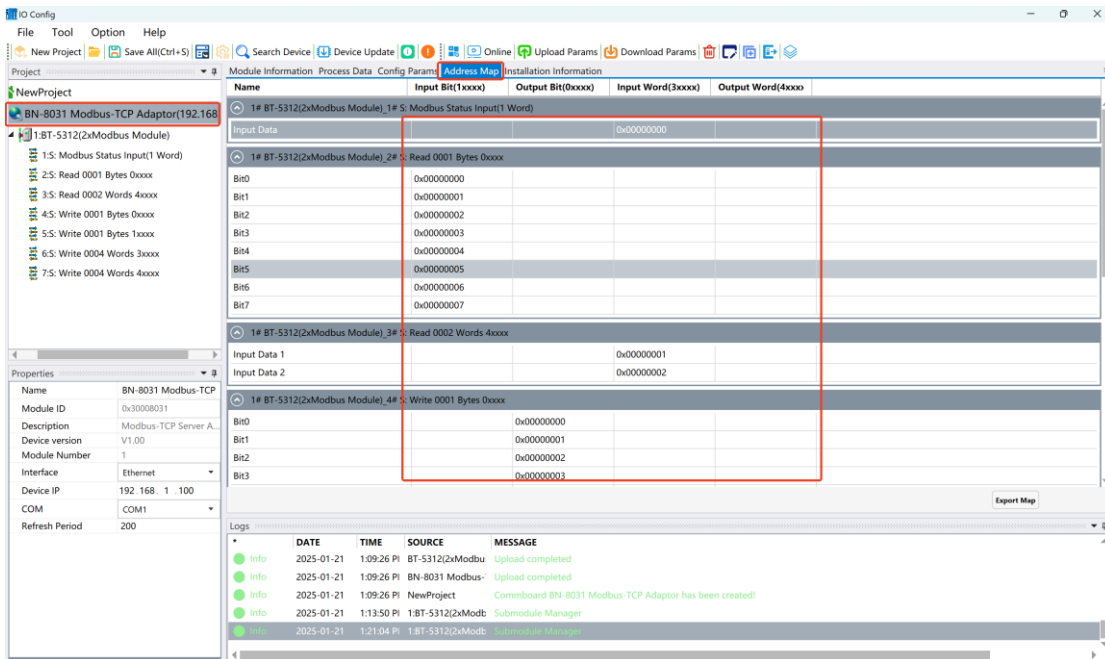

2. TIA V16 collects data

Open the TIA V16 software, create a new project and click "BT5312S".

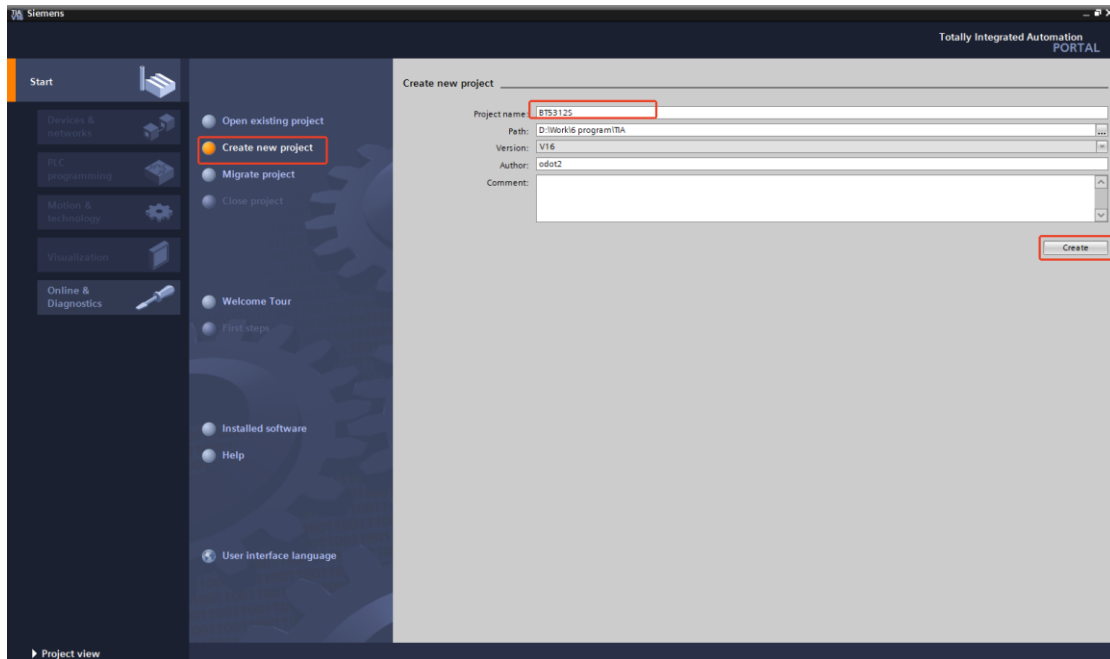

Click Add Device and select “CPU 1214 DC/DC/DC 6ES7 214-1AG40-0XB0”, click OK.

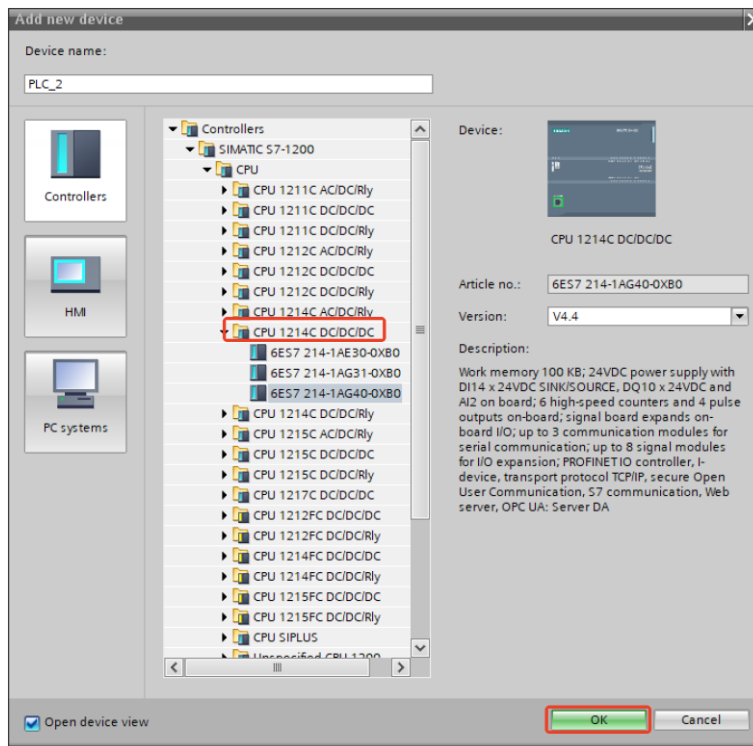

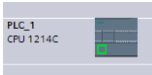
Click the , select the IP address, set the IP address as 192.168.0.1, add a

new subnet PN/IE_1.

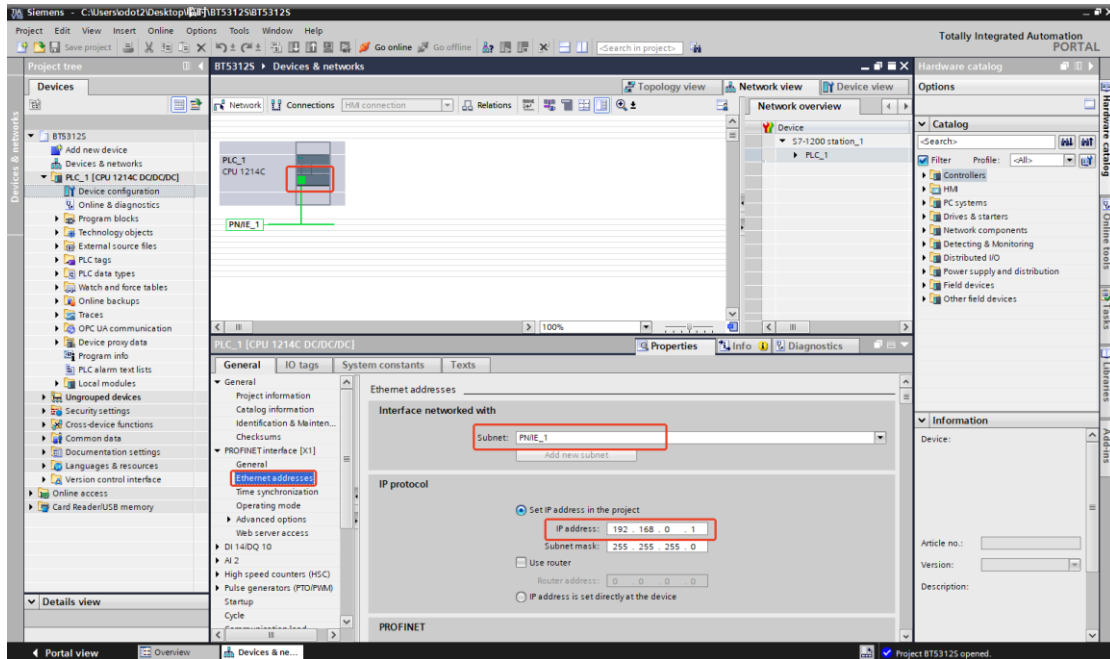

Add a new block in the block drop-down menu, and add data blocks DB1, DB2, DB3, DB4 and DB5. DB1 is used for S7-1200 to establish a connection with BN-8031, DB2 is used to store 1xxxx data, DB3 is used to store 3xxxx data, DB4 is used to store 0xxxx data, and DB5 is used to store 4xxxx data. (IP of BN-8031: 192.168.1.100), the IP address of the module can be viewed and modified through IO Config software).

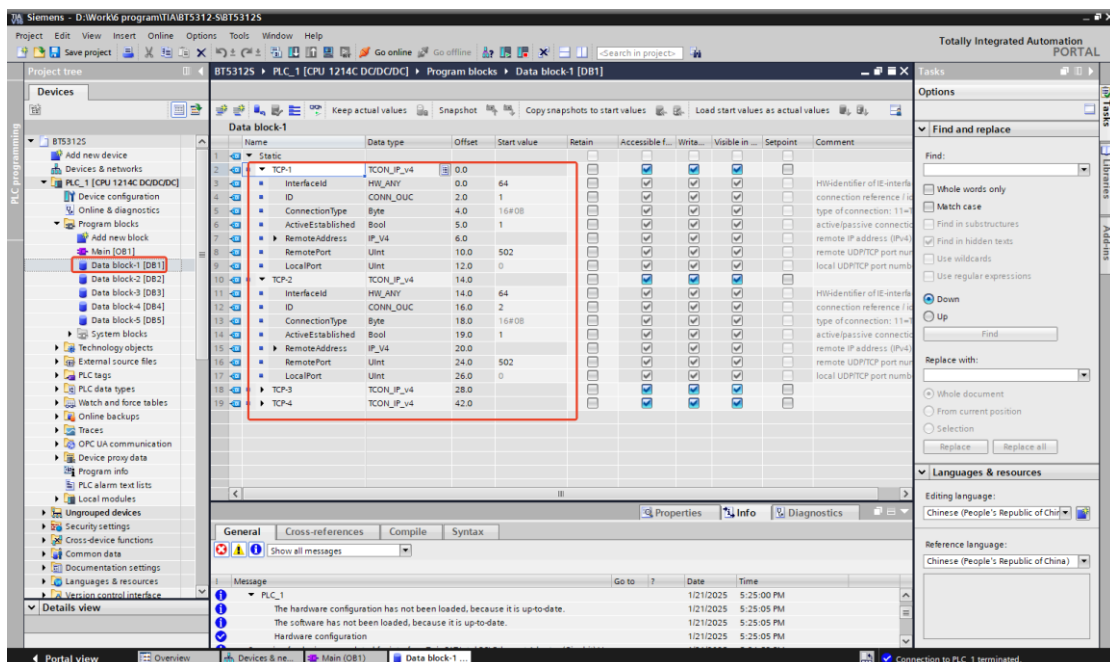

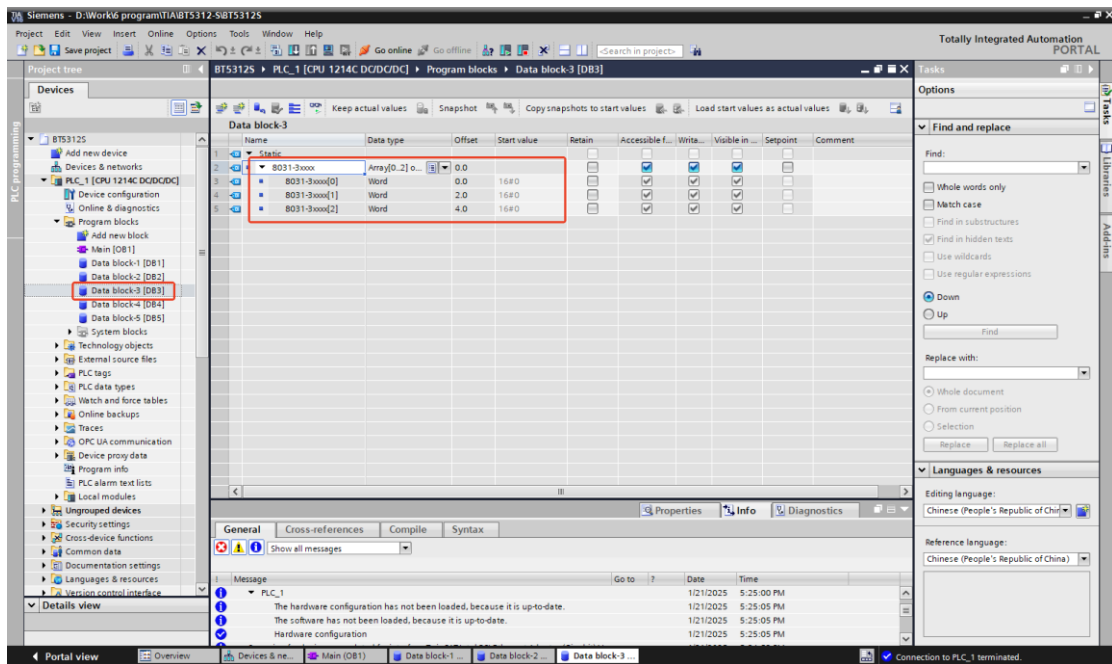
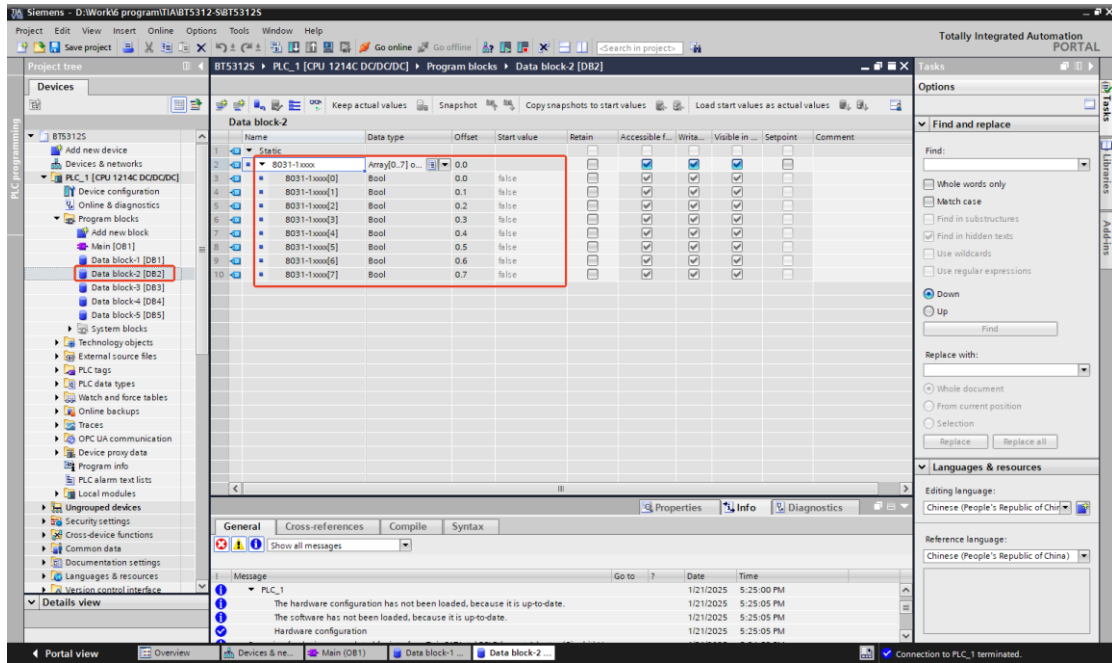

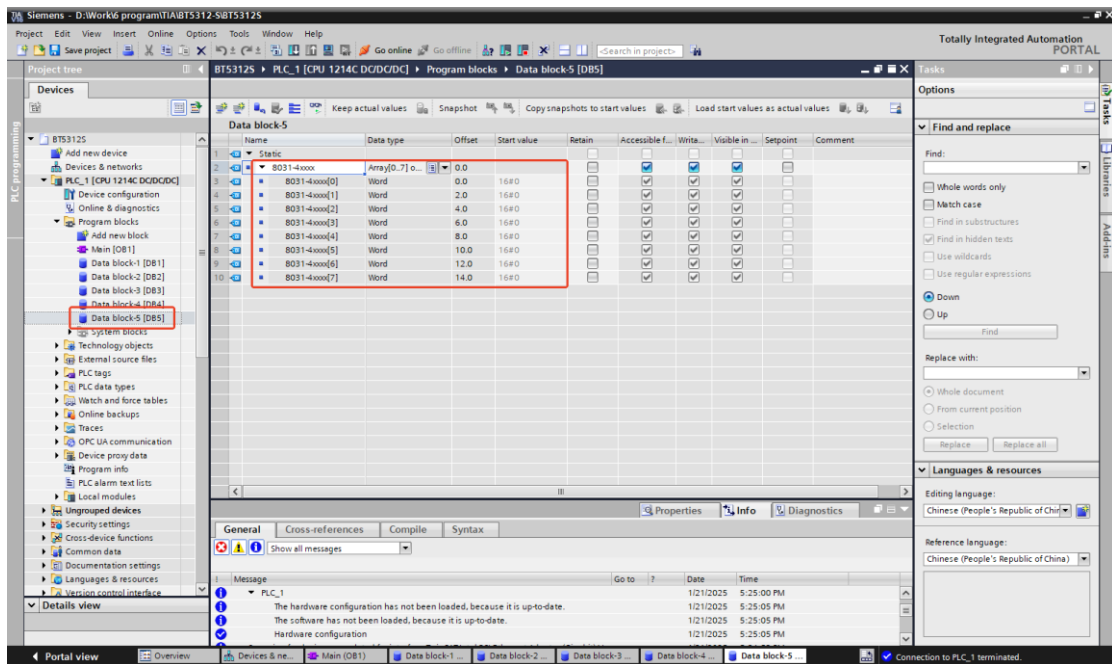
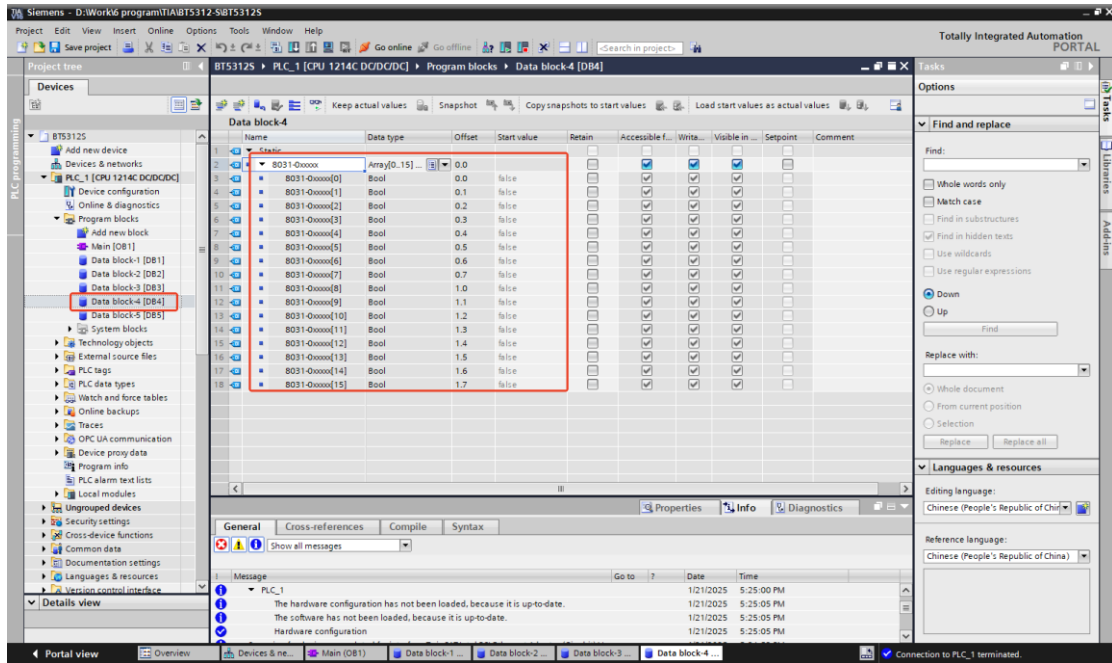

After a new block is created, each block needs to be compiled. Note: DB1, DB2, DB3, DB4, and DB5 right-click attributes, remove the before accessing the optimized block.

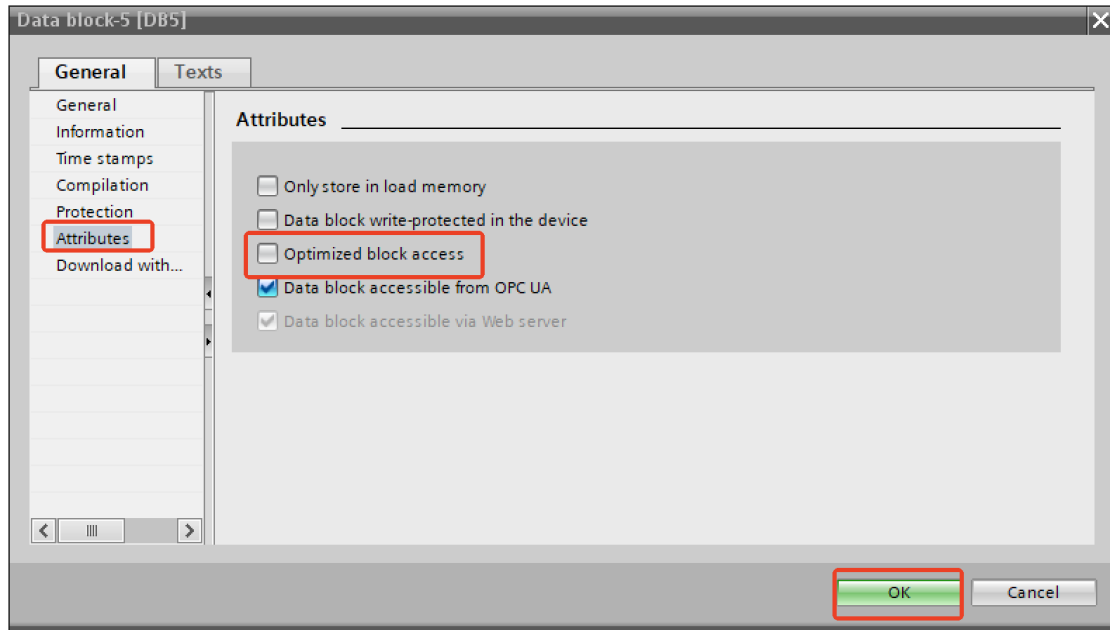

In the program block drop-down menu, double-click Mian [OB1], find the command on the right MB_CLIENT drag it to program section 1. Modify the parameters as shown in the figure.

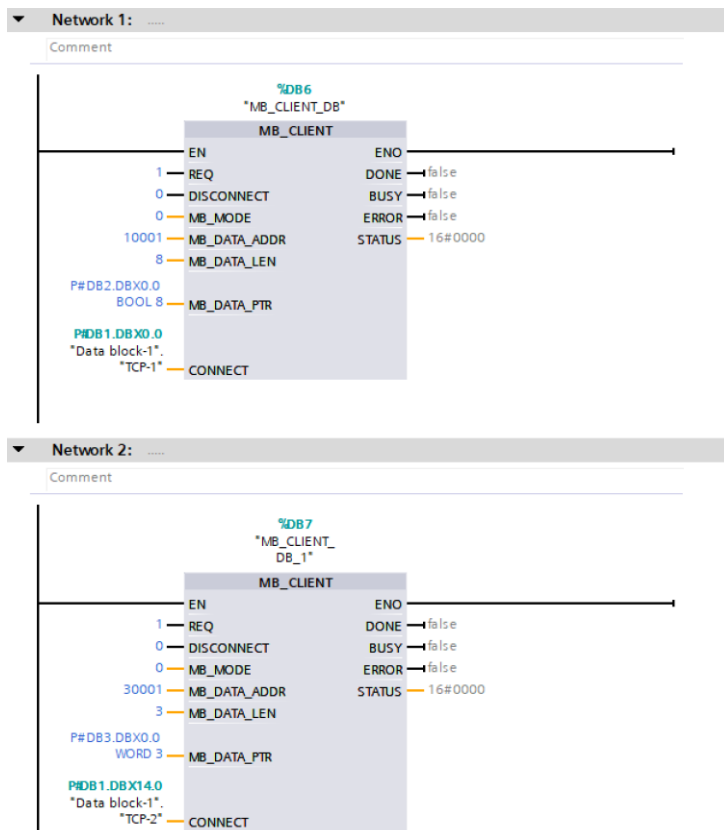

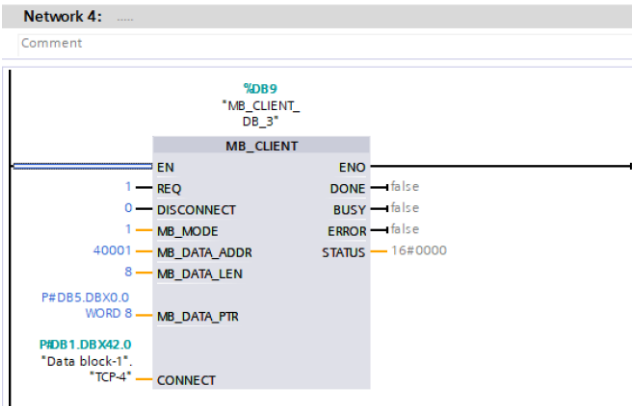
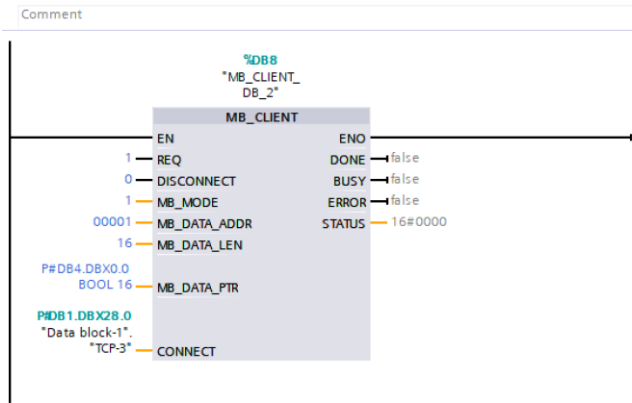

After the setting is completed, save, compile, download, and go online after the download is completed.

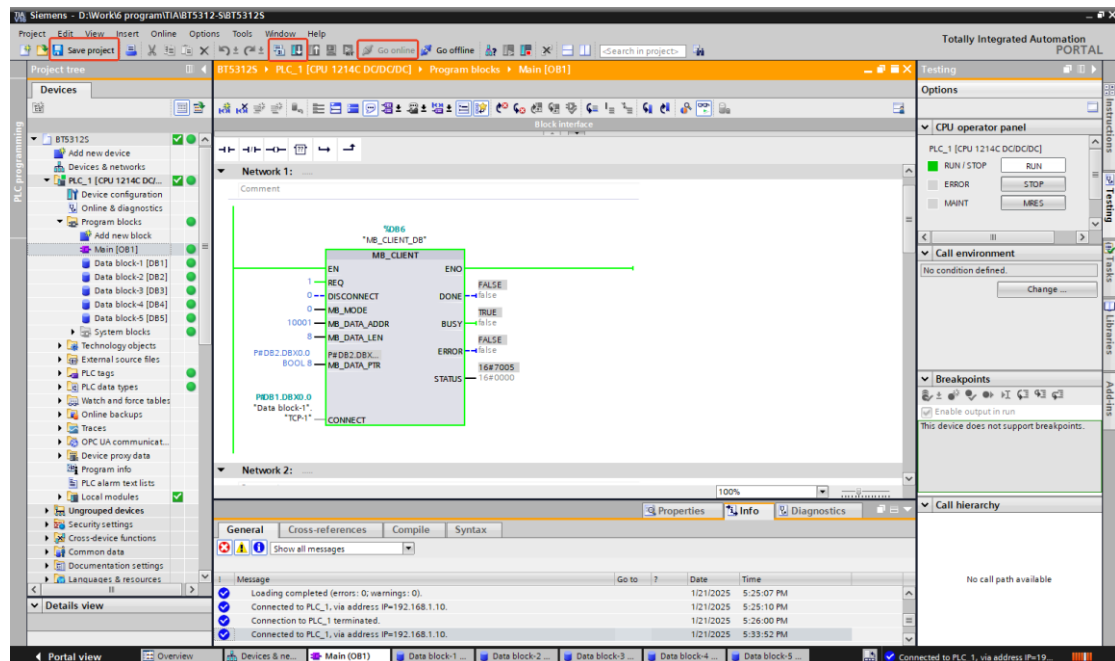

Use the Modbus Poll software to emulate the RS485 master device on serial port 1, and add a new monitoring table on which the field device values can be monitored

online.

The screenshot shows the Siemens TIA Portal interface for a project named 'BTS3125'. The main window displays the configuration for 'Data block 2 [DB2]'. The table below represents the data in this block:

Name	Data type	Offset	Start value	Monitor value	Retain	Accessible F.	Write	Visible in	Setpoint
1	Static								
2	8031-1xxxx	Array[0..7]	0.0	false					
3	8031-1xxxx[0]	Bool	0.0	false					
4	8031-1xxxx[1]	Bool	0.1	false					
5	8031-1xxxx[2]	Bool	0.2	false					
6	8031-1xxxx[3]	Bool	0.3	false					
7	8031-1xxxx[4]	Bool	0.4	false					
8	8031-1xxxx[5]	Bool	0.5	false					
9	8031-1xxxx[6]	Bool	0.6	false					
10	8031-1xxxx[7]	Bool	0.7	false					

Below the table, a 'Modbus Poll - Mbpoll2' window is open, showing a table of data:

Alias	00100
0	1
1	0
2	1
3	0
4	1
5	0
6	0
7	0
8	0
9	0

The screenshot shows the Siemens TIA Portal interface for the same project, now displaying the configuration for 'Data block 3 [DB3]'. The table below represents the data in this block:

Name	Data type	Offset	Start value	Monitor value	Retain	Accessible F.	Write	Visible in	Setpoint
1	Static								
2	8031-3xxxx	Array[0..2]	0.0						
3	8031-3xxxx[0]	Word	0.0	16A000					
4	8031-3xxxx[1]	Word	2.0	16A09DA					
5	8031-3xxxx[2]	Word	4.0	16A03C4					

Below the table, a 'Modbus Poll - Mbpoll2' window is open, showing a table of data:

Alias	00100
0	(??) 0x09DA
1	(??) 0x03C4
2	
3	
4	
5	
6	
7	
8	
9	

The screenshot shows the Siemens TIA Portal interface for a project named 'BTS3125'. The main window displays 'Watch table_1' with the following data:

Name	Address	Display format	Monitor value	Modify value
"Data block-4"."8031-Qxxxxx"[0]	%DB4.DBX0.0	Bool	TRUE	TRUE
"Data block-4"."8031-Qxxxxx"[1]	%DB4.DBX0.1	Bool	TRUE	TRUE
"Data block-4"."8031-Qxxxxx"[2]	%DB4.DBX0.2	Bool	FALSE	FALSE
"Data block-4"."8031-Qxxxxx"[3]	%DB4.DBX0.3	Bool	FALSE	FALSE
"Data block-4"."8031-Qxxxxx"[4]	%DB4.DBX0.4	Bool	FALSE	FALSE
"Data block-4"."8031-Qxxxxx"[5]	%DB4.DBX0.5	Bool	FALSE	FALSE
"Data block-4"."8031-Qxxxxx"[6]	%DB4.DBX0.6	Bool	FALSE	FALSE
"Data block-4"."8031-Qxxxxx"[7]	%DB4.DBX0.7	Bool	FALSE	FALSE
"Data block-4"."8031-Qxxxxx"[8]	%DB4.DBX1.0	Bool	FALSE	FALSE
"Data block-4"."8031-Qxxxxx"[9]	%DB4.DBX1.1	Bool	FALSE	FALSE
"Data block-4"."8031-Qxxxxx"[10]	%DB4.DBX1.2	Bool	FALSE	FALSE
"Data block-4"."8031-Qxxxxx"[11]	%DB4.DBX1.3	Bool	FALSE	FALSE
"Data block-4"."8031-Qxxxxx"[12]	%DB4.DBX1.4	Bool	FALSE	FALSE
"Data block-4"."8031-Qxxxxx"[13]	%DB4.DBX1.5	Bool	TRUE	TRUE
"Data block-4"."8031-Qxxxxx"[14]	%DB4.DBX1.6	Bool	TRUE	TRUE
"Data block-4"."8031-Qxxxxx"[15]	%DB4.DBX1.7	Bool	TRUE	TRUE

Two Modbus Poll windows are open, showing data for Mbpoll2 and Mbpoll3:

Alias	Value
0	00000
1	1
2	0
3	0
4	0
5	0
6	1
7	1
8	1
9	0

Alias	Value
0	0
1	0
2	0
3	0
4	0
5	1
6	1
7	1
8	1
9	0

The screenshot shows the Siemens TIA Portal interface for a project named 'BTS3125'. The main window displays 'Watch table_2' with the following data:

Name	Address	Display format	Monitor value	Modify value
"Data block-5"."8031-Qxxxxx"[0]	%DB5.DBW0	DEC	532	532
"Data block-5"."8031-Qxxxxx"[1]	%DB5.DBW2	DEC	850	850
"Data block-5"."8031-Qxxxxx"[2]	%DB5.DBW4	DEC	323	323
"Data block-5"."8031-Qxxxxx"[3]	%DB5.DBW6	DEC	1330	1330
"Data block-5"."8031-Qxxxxx"[4]	%DB5.DBW8	DEC	323	323
"Data block-5"."8031-Qxxxxx"[5]	%DB5.DBW10	DEC	532	532
"Data block-5"."8031-Qxxxxx"[6]	%DB5.DBW12	DEC	1329	1329
"Data block-5"."8031-Qxxxxx"[7]	%DB5.DBW14	DEC	325	325

Two Modbus Poll windows are open, showing data for Mbpoll4 and Mbpoll3:

Alias	Value
0	532
1	850
2	323
3	1330
4	
5	
6	
7	
8	
9	

Alias	Value
0	323
1	532
2	1329
3	325
4	
5	
6	
7	
8	
9	

3 BT-5312 works in free port communication mode

3.1 Report mode

Note: 1. It needs to use IO Config to set parameters.

2. If not using the latest version of IO Config, it needs to update the device description file (hardware support package) or install the latest version of IO Config.

1. Configure the parameters of the BT-5312 module

Hardware Composition: BN-8031, BT-5312 with Siemens S7-1200.

1. Power the BN-8031 module to 24VDC, and connect the network cable directly to the PC and BN-8031. BT-5312 wiring A1+ B1 - connect to 485 to USB converter, USB serial port to PC. Provide 24VDC to the S7-1200 and BN-8031 modules respectively, connect the network port of S7-1200 to Port2 of BN-8031, and connect Port1 of BN-8031 to PC for configuration. BT-5312 wiring A+B- to 485 to USB converter, USB serial port to PC.

2. Open the IO Config software, click Search Device, select the local network card, click Search Device, click Upload, and the project will be automatically generated.

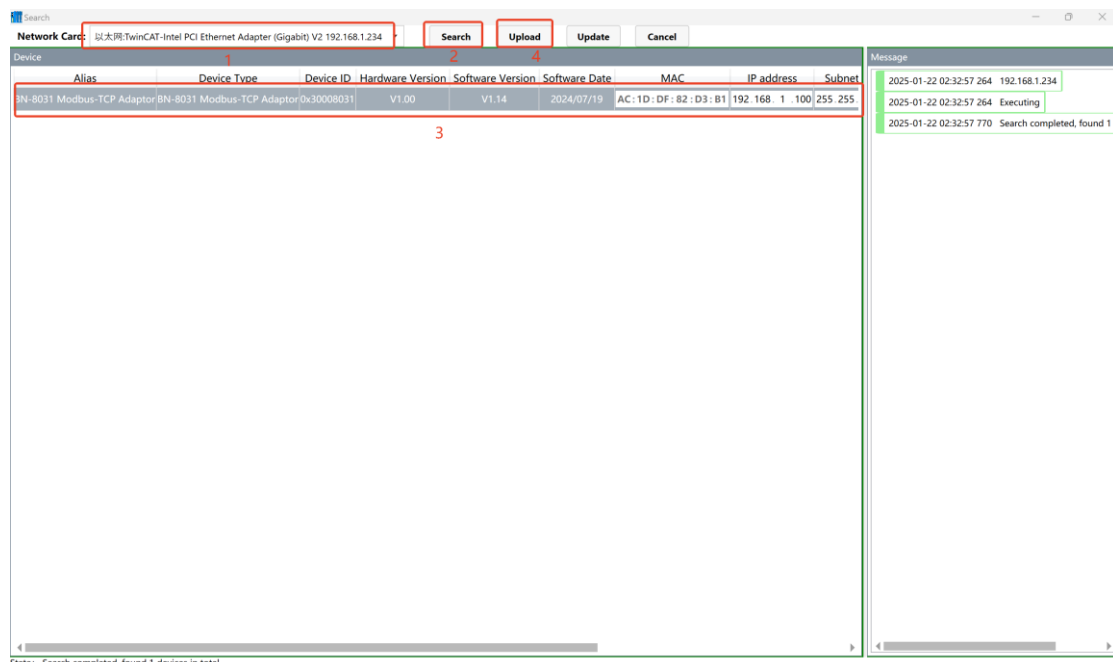

After uploading the module, it can configure the parameters of BT-5312, select the BT-5312 module, click Configure Parameters, and set the working mode of serial port 1: Freeport mode, 9600bps, N, 8, 1, RTU.

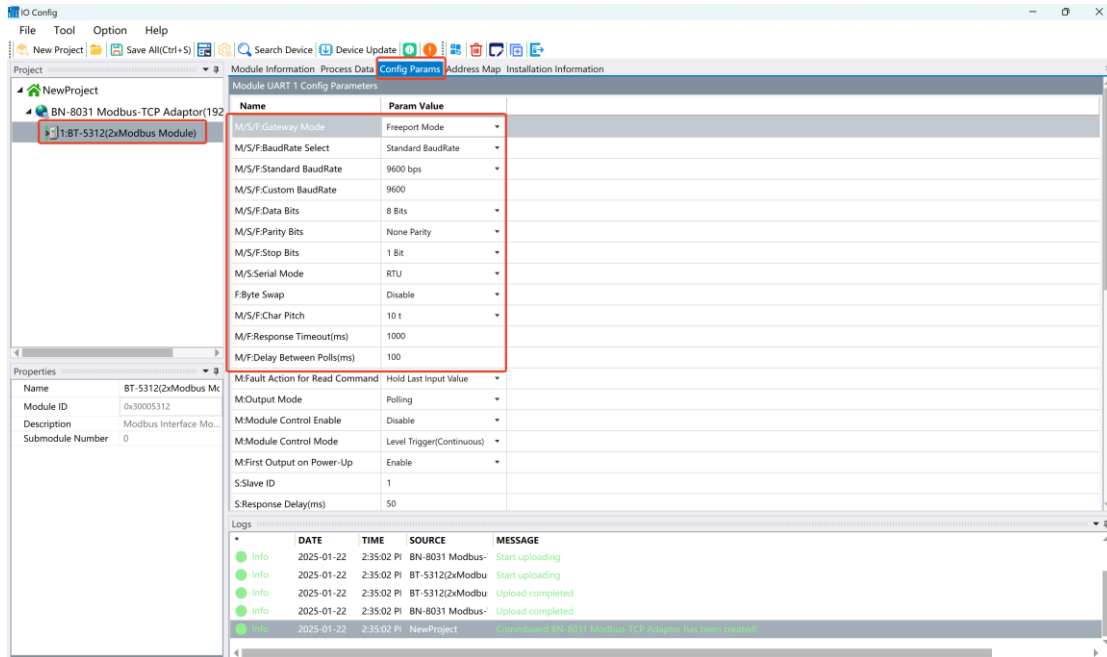

Right-click BT-5312, select Submodule Manager, in the pop-up window, select Input Commands and Control and Status Module in Free Transparent Transmission Mode, and click OK. **Note: The M/S/F here represent the valid parameters of the master (M), slave (S), and free transparent transmission (F) modes, respectively.**

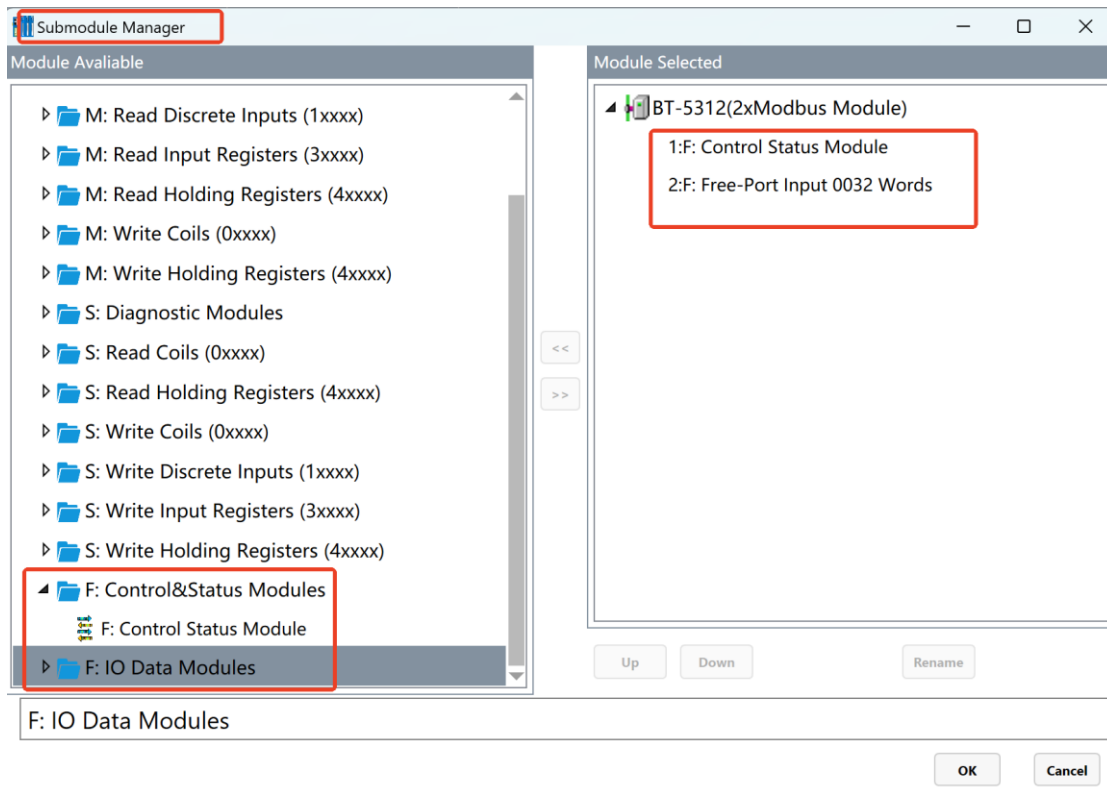

Select the control and status module commands, click the configuration parameters,

and it can set the COM number and set the communication mode to Report.

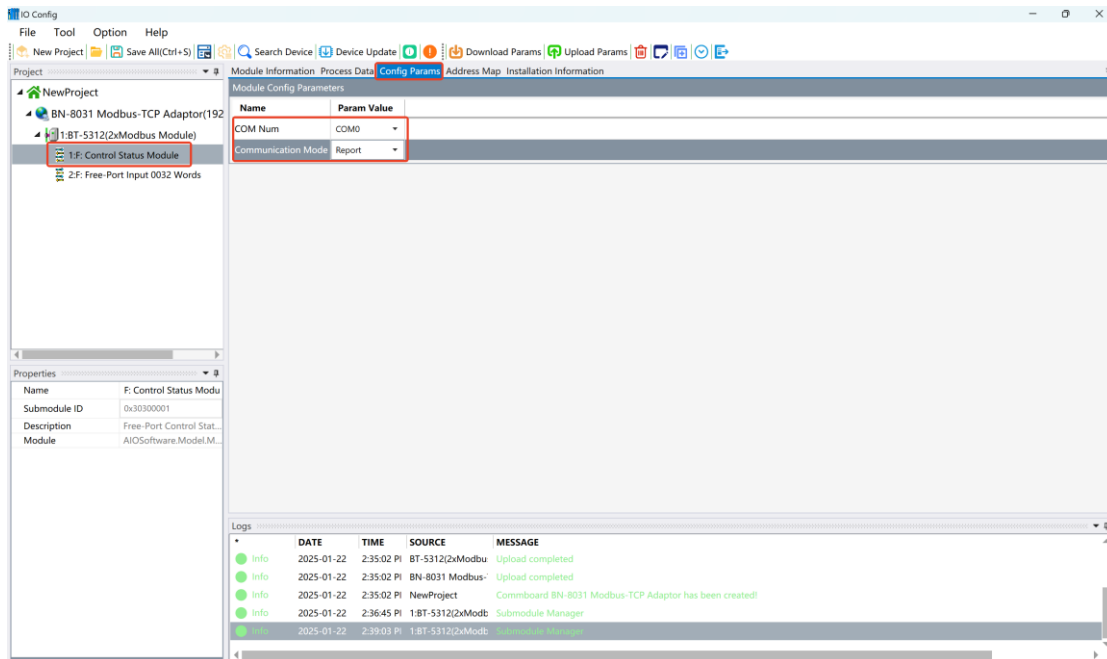

After all parameters are configured, right-click BN-8031 and select Download Configuration.

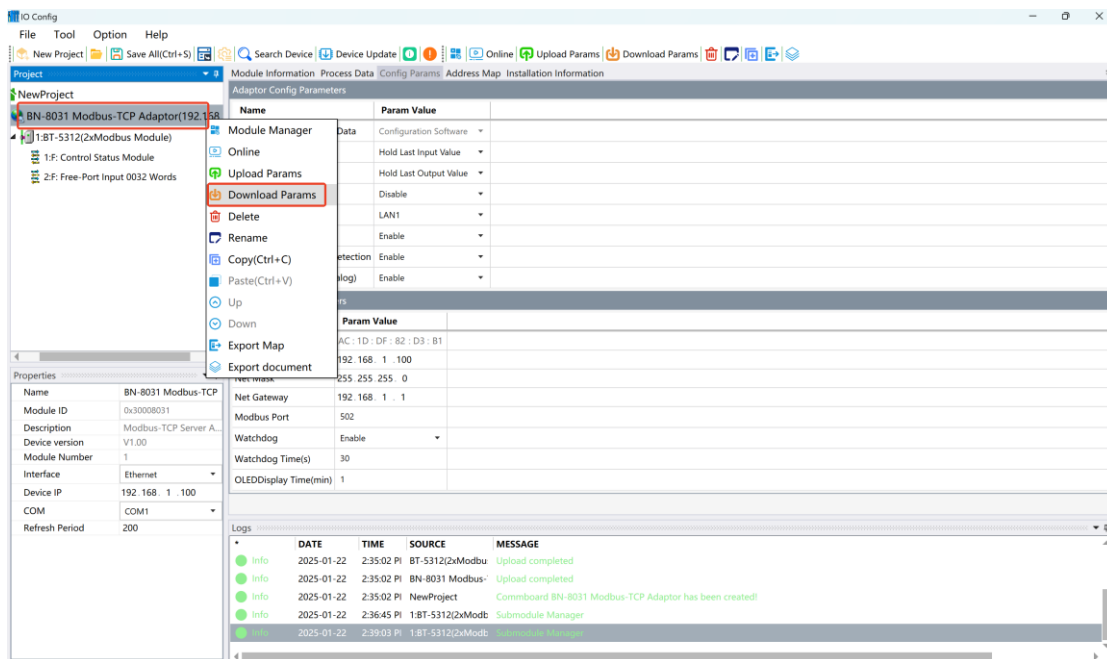

Select BN-8031 and click the address map to view the address mapping relationship.

The screenshot displays the 'IO Config' software interface. The main window is titled 'Address Map' and shows a configuration table for a 'BN-8031 Modbus-TCP Adaptor'. The table has four columns: 'Name', 'Input Bit(1xxxx)', 'Output Bit(0xxxx)', 'Input Word(3xxxx)', and 'Output Word(4xxx)'. The configuration is organized into two sections: 'Control Status Module' and 'Free-Port Input 0032 Words'. The 'Control Status Module' section includes rows for 'Control Word', 'Send Bytes Len', 'COM Status', 'Error Counter', 'Received Counter', 'Received Bytes Len', and 'Send Bytes Len'. The 'Free-Port Input 0032 Words' section includes rows for 'Input Data 1' through 'Input Data 11'. The 'Properties' panel on the left shows details for the 'BN-8031 Modbus-TCP' device, including its name, module ID, description, device version, module number, interface (Ethernet), device IP (192.168.1.100), COM port (COM1), and refresh period (200). The 'Logs' window at the bottom shows a series of informational messages, including 'Upload completed' and 'Commboard BN-8031 Modbus-TCP Adaptor has been created!'.

Name	Input Bit(1xxxx)	Output Bit(0xxxx)	Input Word(3xxxx)	Output Word(4xxx)
Control Status Module				
Control Word			0x00000000	
Send Bytes Len			0x00000001	
COM Status			0x00000002	
Error Counter			0x00000003	
Received Counter			0x00000004	
Received Bytes Len			0x00000005	
Control Word				0x00000000
Send Bytes Len				0x00000001
Free-Port Input 0032 Words				
Input Data 1			0x00000006	
Input Data 2			0x00000007	
Input Data 3			0x00000008	
Input Data 4			0x00000009	
Input Data 5			0x0000000A	
Input Data 6			0x0000000B	
Input Data 7			0x0000000C	
Input Data 8			0x0000000D	
Input Data 9			0x0000000E	
Input Data 10			0x0000000F	
Input Data 11			0x00000010	

2. TIA V16 collects data

Open the TIA V16 software and click Create to create the new project "BT5312-F".

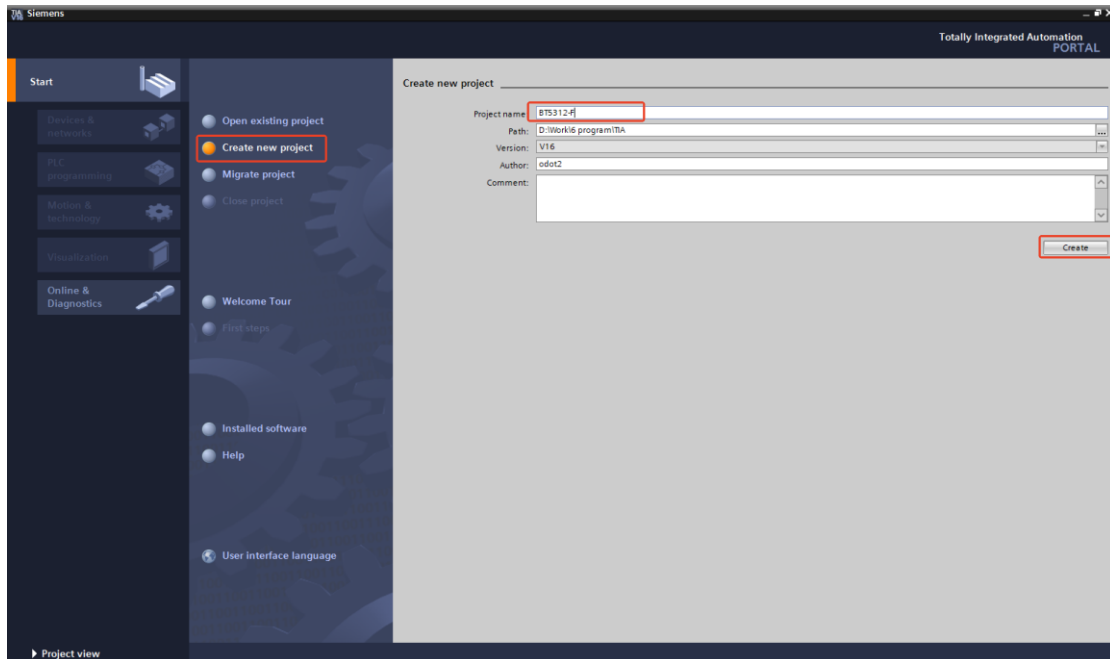

Click Add Device and select “CPU 1214 DC/DC/DC 6ES7 214-1AG40-0XB0”, click OK.

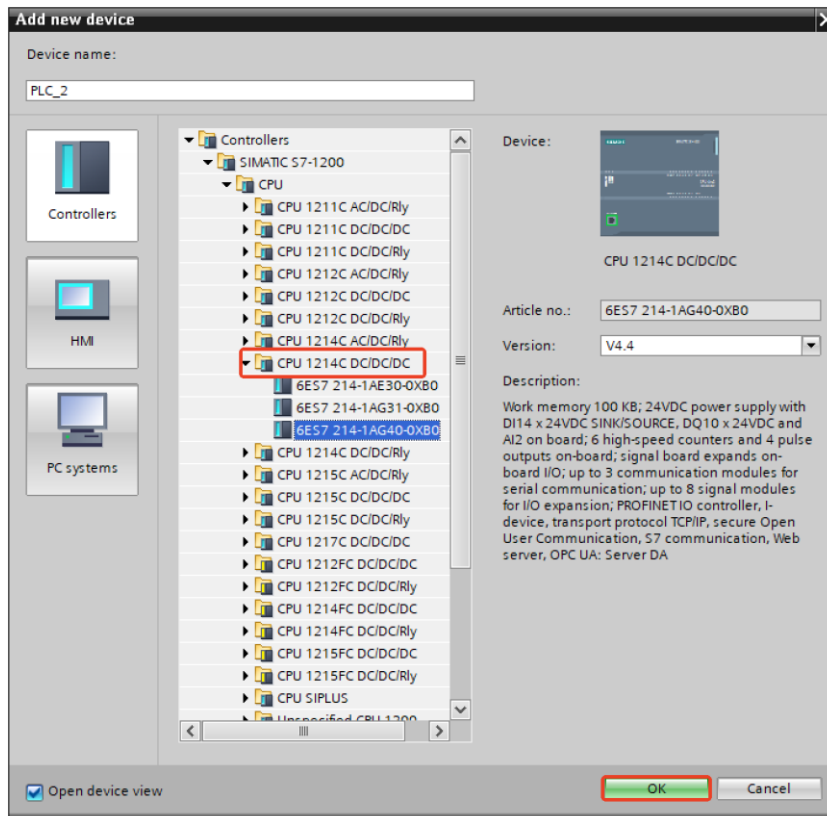

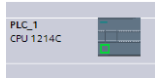

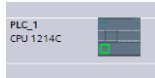
Click the , select the Ethernet addresses, set the IP address as 192.168.1.10, add a new subnet PN/IE_1.

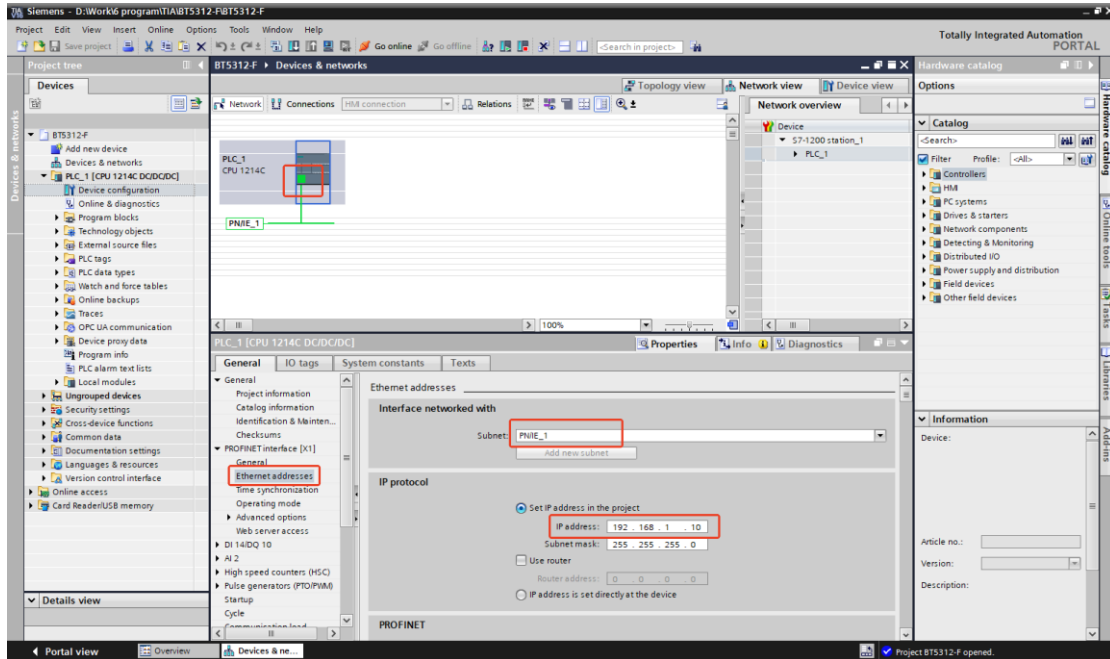

Add a new block in the block drop-down menu, and add data blocks DB1 and DB2. DB1 is used for S7-1200 to establish a connection with BN-8031, and DB2 is used to store 3xxxx data. (IP address of BN-8031: 192.168.1.100), the IP address of the module can be viewed and configured through IO Config software).

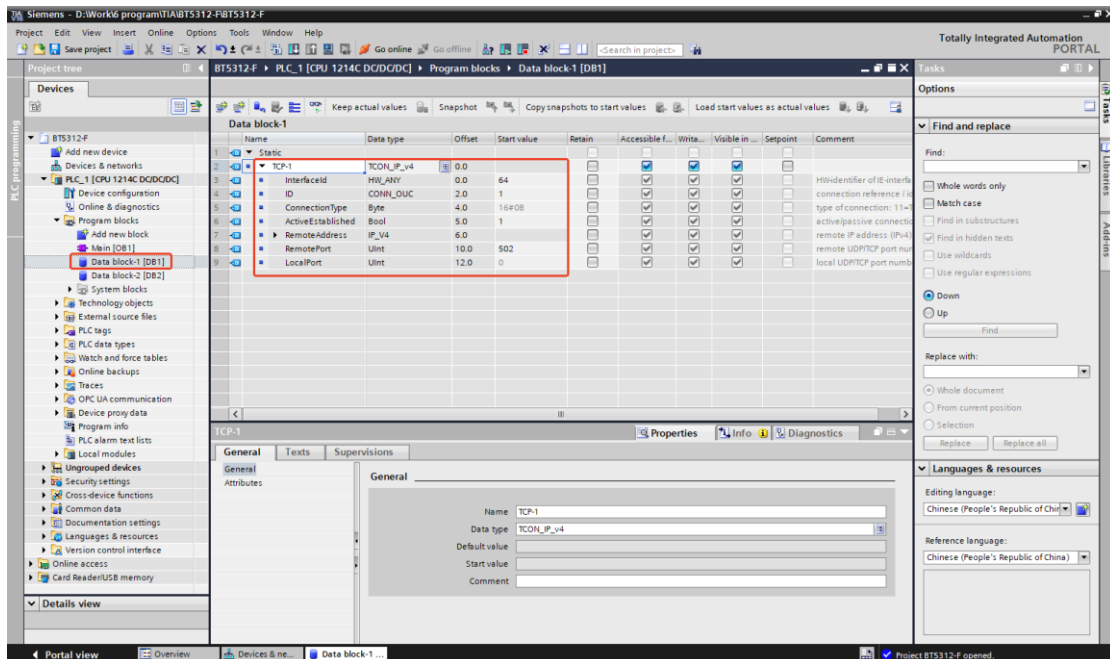

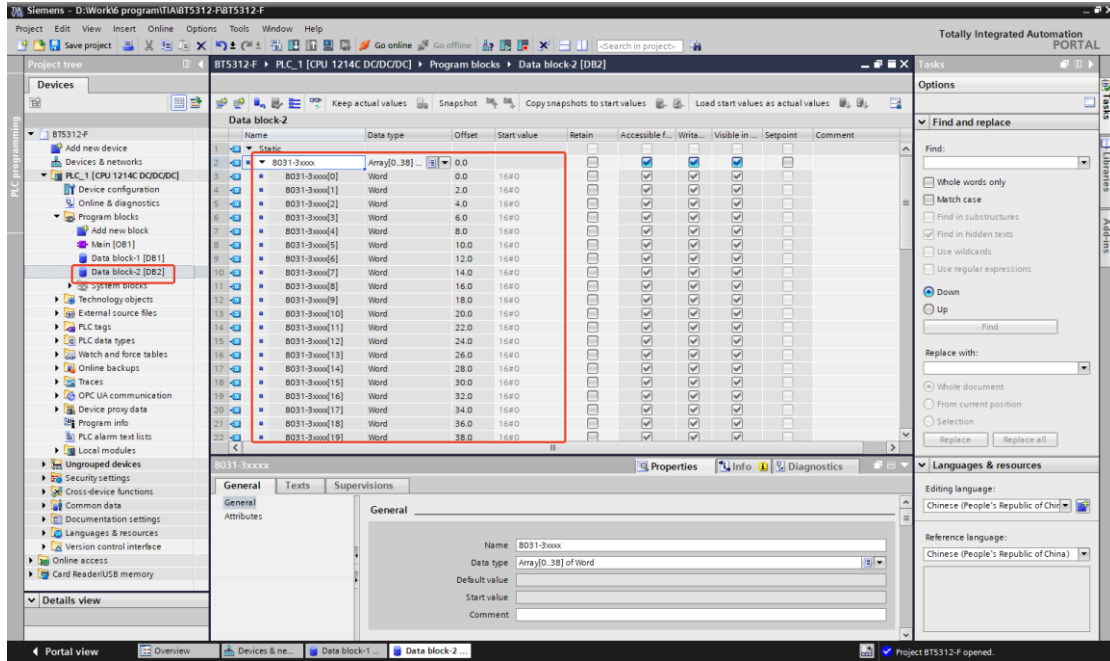

After a new block is created, each block needs to be compiled. Note: DB1 and DB2 right-click attributes, remove the ✓ before accessing the optimized block.

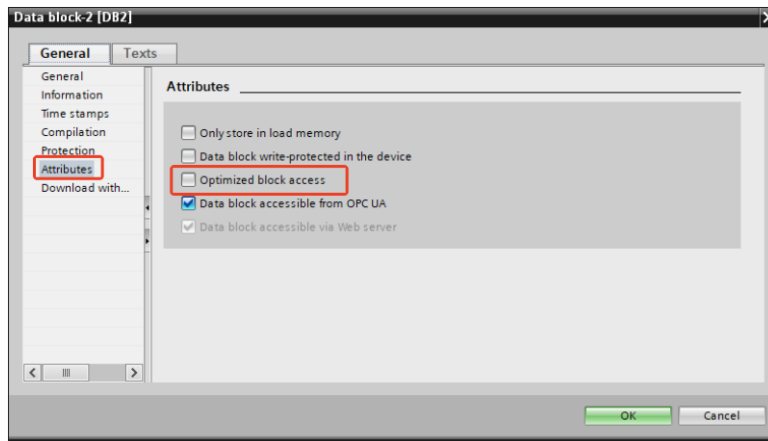

In the block drop-down menu, double-click Mian [OB1], find the command on the right MB_CLIENT drag it to section 1. Modify the parameters as shown in the figure.

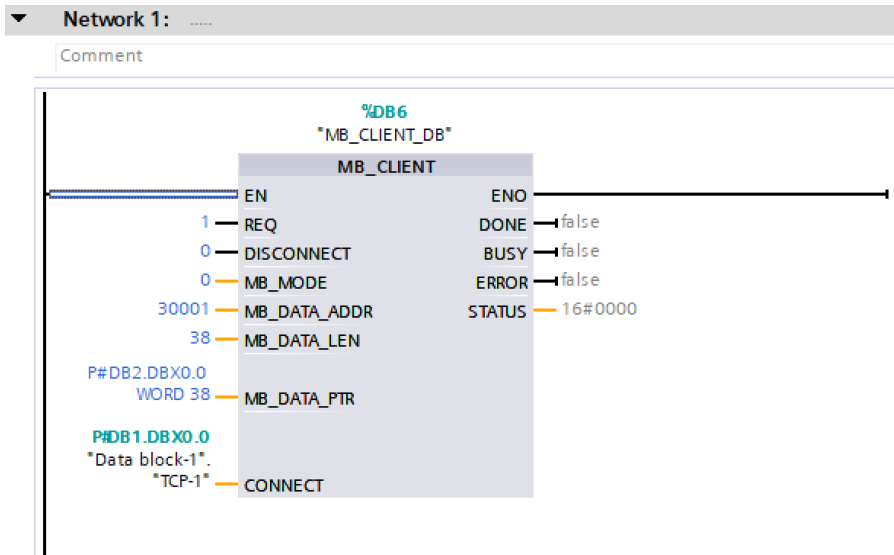

Once the setup is complete, save, compile, download, and go online after the download is complete.

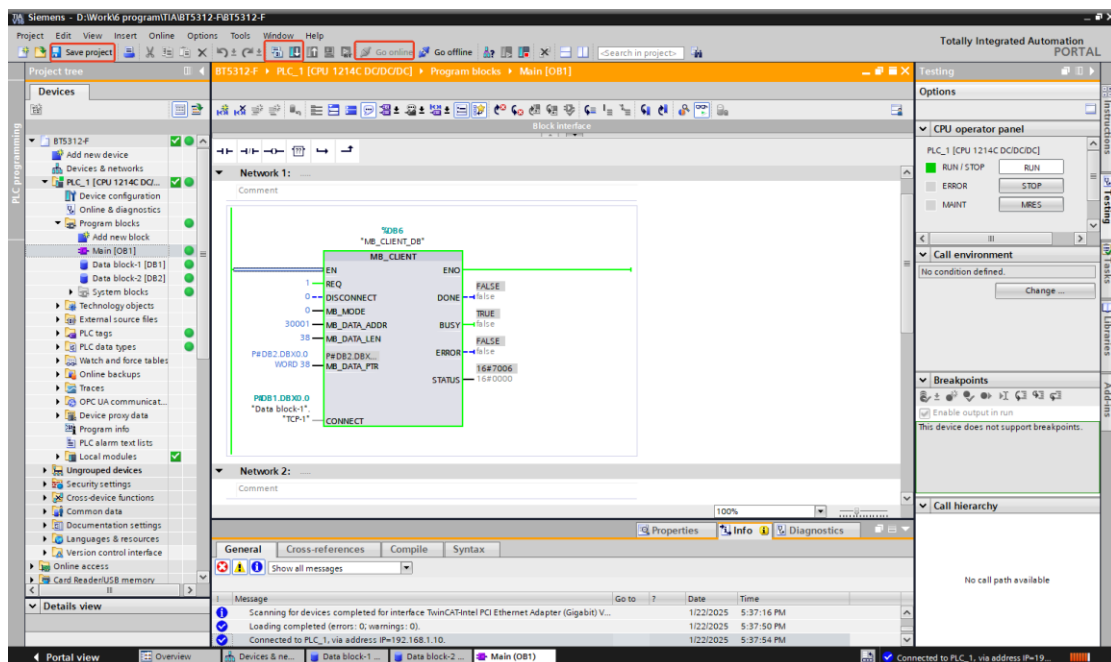

Use the Friendly Serial port utility software to simulate RS485 devices and monitor field device values online in DB2 blocks.

The screenshot displays the Siemens SIMATIC Manager interface. The main window shows the configuration for 'Data block-2' (DB2) in a PLC. The table below represents the data block structure:

Name	Data type	Offset	Start value	Monitor value	Retain	Accessible f.	Write	Visible in	Setpoint
Static									
8031-3xxx[0]	Word	0.0	16#0	16#0000					
8031-3xxx[1]	Word	2.0	16#0	16#0000					
8031-3xxx[2]	Word	4.0	16#0	16#0000					
8031-3xxx[3]	Word	6.0	16#0	16#0000					
8031-3xxx[4]	Word	8.0	16#0	16#0001					
8031-3xxx[5]	Word	10.0	16#0	16#0007					
8031-3xxx[6]	Word	12.0	16#0	16#1312					
8031-3xxx[7]	Word	14.0	16#0	16#1514					
8031-3xxx[8]	Word	16.0	16#0	16#1716					
8031-3xxx[9]	Word	18.0	16#0	16#0018					
8031-3xxx[10]	Word	20.0	16#0	16#0000					
8031-3xxx[11]	Word	22.0	16#0	16#0000					
8031-3xxx[12]	Word	24.0	16#0	16#0000					
8031-3xxx[13]	Word	26.0	16#0	16#0000					
8031-3xxx[14]	Word	28.0	16#0	16#0000					
8031-3xxx[15]	Word	30.0	16#0	16#0000					
8031-3xxx[16]	Word	32.0	16#0	16#0000					
8031-3xxx[17]	Word	34.0	16#0	16#0000					
8031-3xxx[18]	Word	36.0	16#0	16#0000					
8031-3xxx[19]	Word	38.0	16#0	16#0000					
8031-3xxx[20]	Word	40.0	16#0	16#0000					
8031-3xxx[21]	Word	42.0	16#0	16#0000					
8031-3xxx[22]	Word	44.0	16#0	16#0000					
8031-3xxx[23]	Word	46.0	16#0	16#0000					

Annotations in the image indicate that the first five rows (addresses 0-4) are for 'Control word and input status' and the next five rows (addresses 6-10) are for 'Input data'. A 'Serial Port Utility' window is overlaid on the right, showing a hex dump of received data: 17 02 35 012 12 13 14 15 16 17 18. The status bar at the bottom indicates 'COM5 OPENED 9600 8 N R: 0 Bytes Tx: 7 Bytes'.

3.2 Reply-Response mode

Note: 1. It needs to use IO Config to set parameters.

2. If not using the latest version of IO Config, it needs to update the device description file (hardware support package) or install the latest version of IO Config.

1. Configure the parameters of the BT-5312 module

Hardware Composition: BN-8031, BT-5312 with Siemens S7-1200.

Power the BN-8031 module to 24VDC, and connect the network cable directly to the PC and BN-8031. BT-5312 wiring A1+ B1 - connect to 485 to USB converter, USB serial port to PC. Provide 24VDC to the S7-1200 and BN-8031 modules respectively, connect the network port of S7-1200 to Port2 of BN-8031, and connect Port1 of BN-8031 to PC for configuration. BT-5312 wiring A+B- to 485 to USB converter, USB serial port to PC.

Open the IO Config software, click Search Device, select the local network card, click Search Device, click Upload, and automatically generate the project.

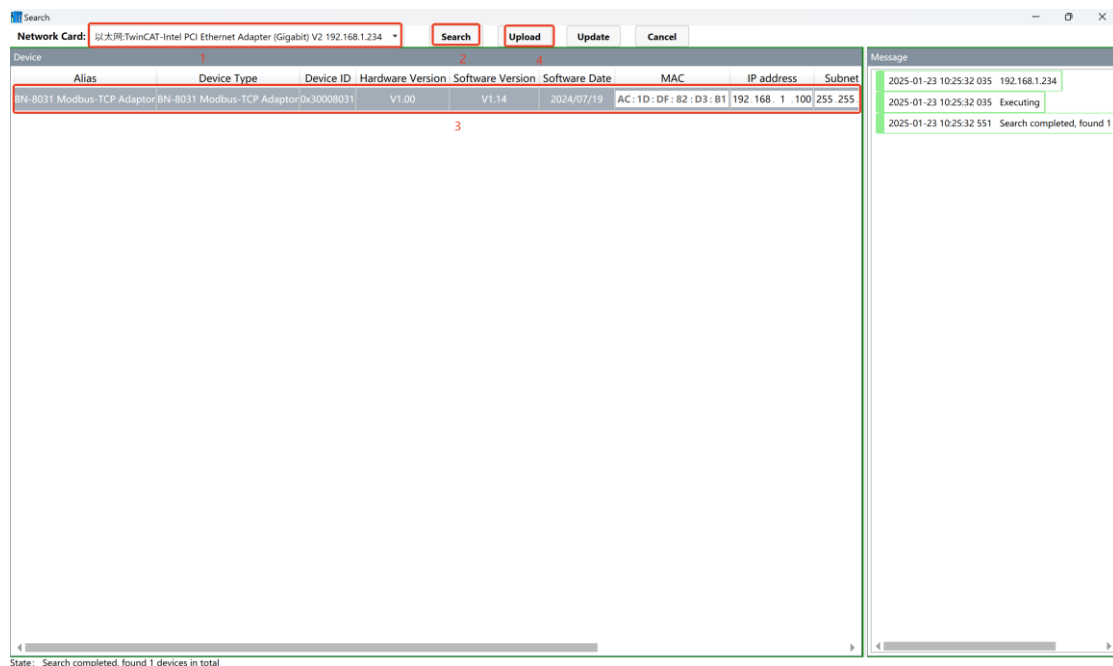

After uploading the module, it can configure the parameters of BT-5312, select the BT-5312 module, click Configure Parameters, and set the working mode of serial port 1: free port communication mode, 9600bps, N, 8, 1, RTU.

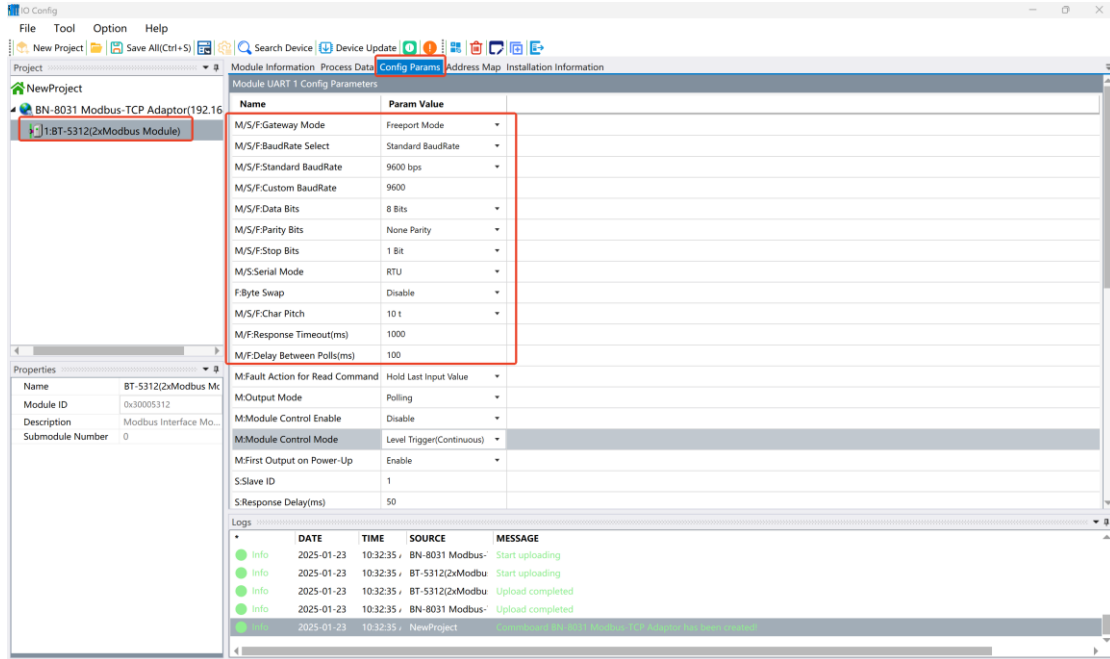

Right-click BT-5312, select Submodule Manager, in the pop-up window, select the read/write command and control and status module in free transparent transmission mode, and click OK. **Note: The M/S/F here represent the valid parameters of the master (M), slave (S), and free transparent transmission (F) modes, respectively.**

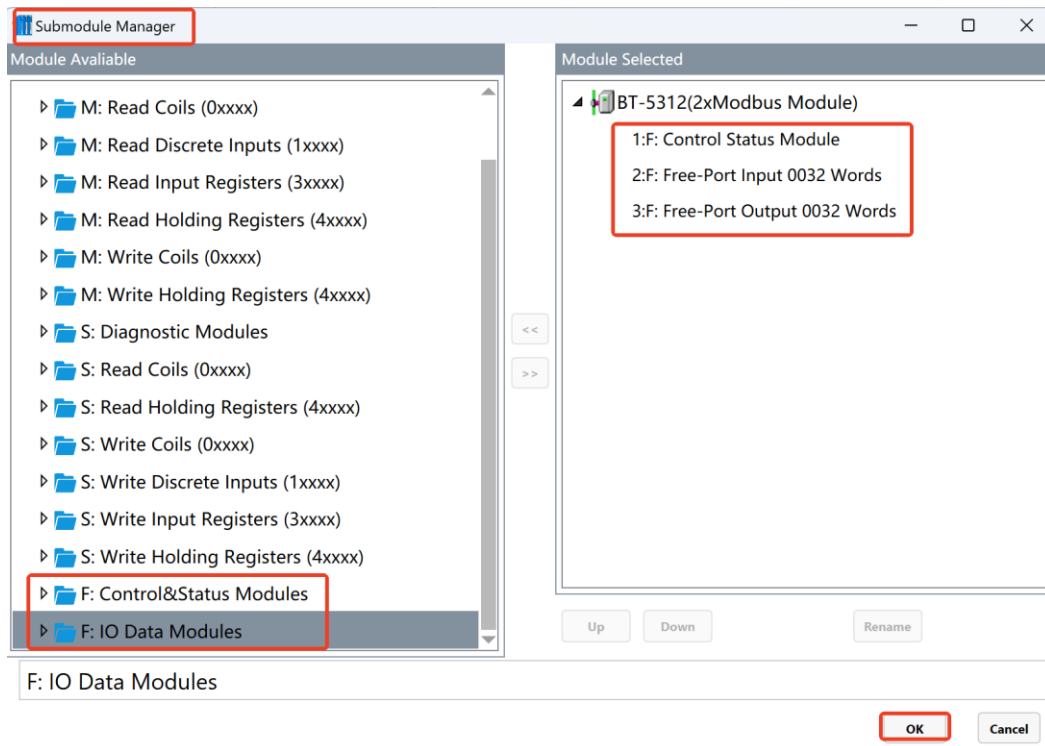

Select the Control and Status module commands, click Configure Parameters, it can set the COM number and set the communication mode to request-response mode.

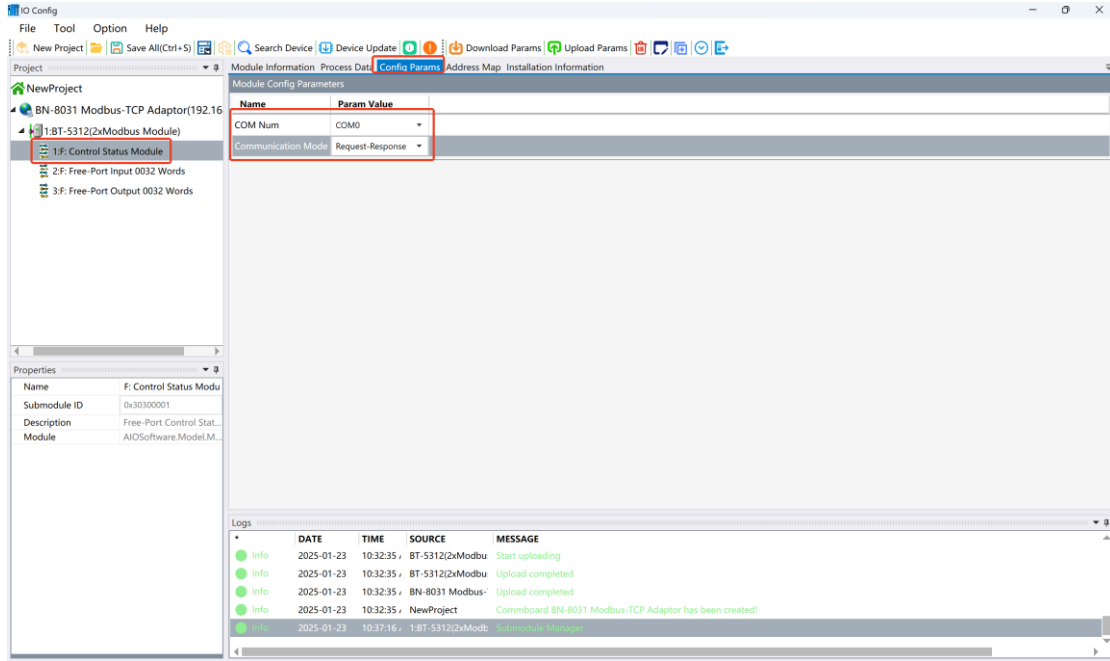

After all parameters are configured, right-click BN-8031 and select Download Configuration.

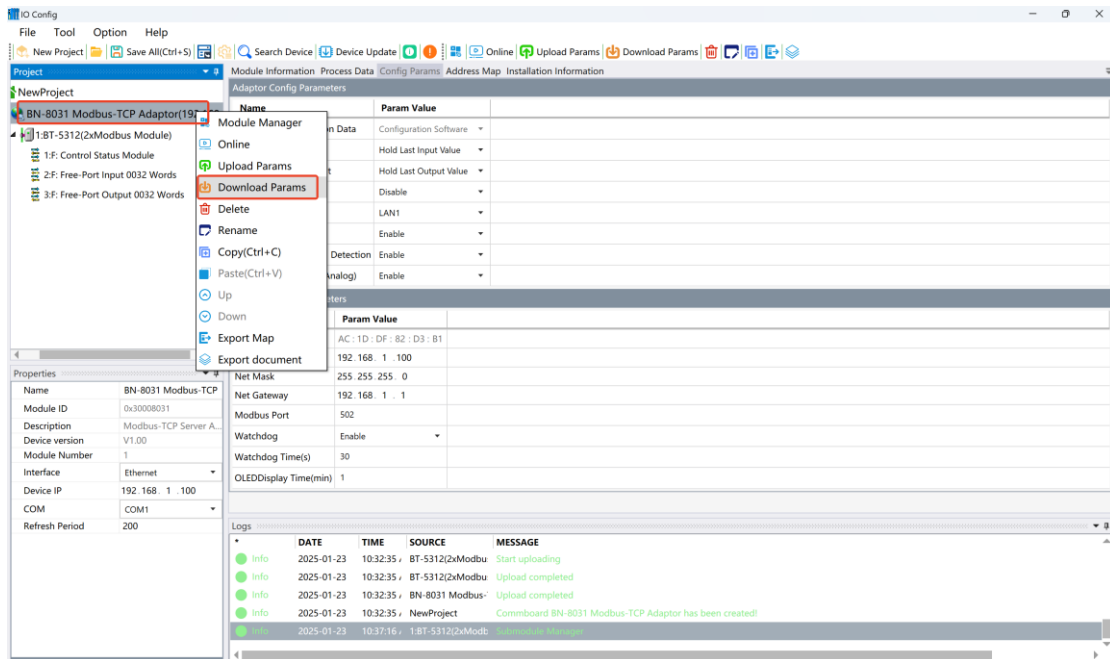

Select BN-8031 and click the address table to view the address mapping relationship.

IO Config

File Tool Option Help

New Project Save All(Ctrl+S) Search Device Device Update Online Upload Params Download Params

Project: Module Information Process Data Config Param **Address Map** Installation Information

NewProject

- BN-8031 Modbus-TCP Adaptor(192.168...)
- 1# BT-5312(2xModbus Module)
- 1# F: Control Status Module
- 2# F: Free-Port Input 0032 Words
- 3# F: Free-Port Output 0032 Words

Properties

Name: BN-8031 Modbus-TCP
 Module ID: 0x30008031
 Description: Modbus-TCP Server A...
 Device version: V1.00
 Module Number: 1
 Interface: Ethernet
 Device IP: 192.168.1.100
 COM: COM1
 Refresh Period: 200

Name	Input Bit(1xxxx)	Output Bit(0xxxx)	Input Word(3xxxx)	Output Word(4xxxx)
1# BT-5312(2xModbus Module)_1# F: Control Status Module				
Control Word			0x00000000	
Send Bytes Len			0x00000001	
COM Status			0x00000002	
Error Counter			0x00000003	
Received Counter			0x00000004	
Received Bytes Len			0x00000005	
Control Word				0x00000000
Send Bytes Len				0x00000001
1# BT-5312(2xModbus Module)_2# F: Free-Port Input 0032 Words				
Input Data 1			0x00000006	
Input Data 2			0x00000007	
Input Data 3			0x00000008	
Input Data 4			0x00000009	
Input Data 5			0x0000000A	
Input Data 6			0x0000000B	
Input Data 7			0x0000000C	
Input Data 8			0x0000000D	
Input Data 9			0x0000000E	
Input Data 10			0x0000000F	
Input Data 11			0x00000010	

Export Map

Logs

	DATE	TIME	SOURCE	MESSAGE
Info	2025-01-23	10:37:16	1#BT-5312(2xModb	Submodule Manager
Info	2025-01-23	10:38:30	Download	Start downloading function data
Info	2025-01-23	10:38:30	Download	Download module configuration data
Info	2025-01-23	10:38:31	Download	Download configs OK! The device is reboot.
Info	2025-01-23	10:38:31	Download	Download configs OK!

2. TIA V16 collects data

Open the TIA V16 software, create a new project "BT5312-R" and click Create.

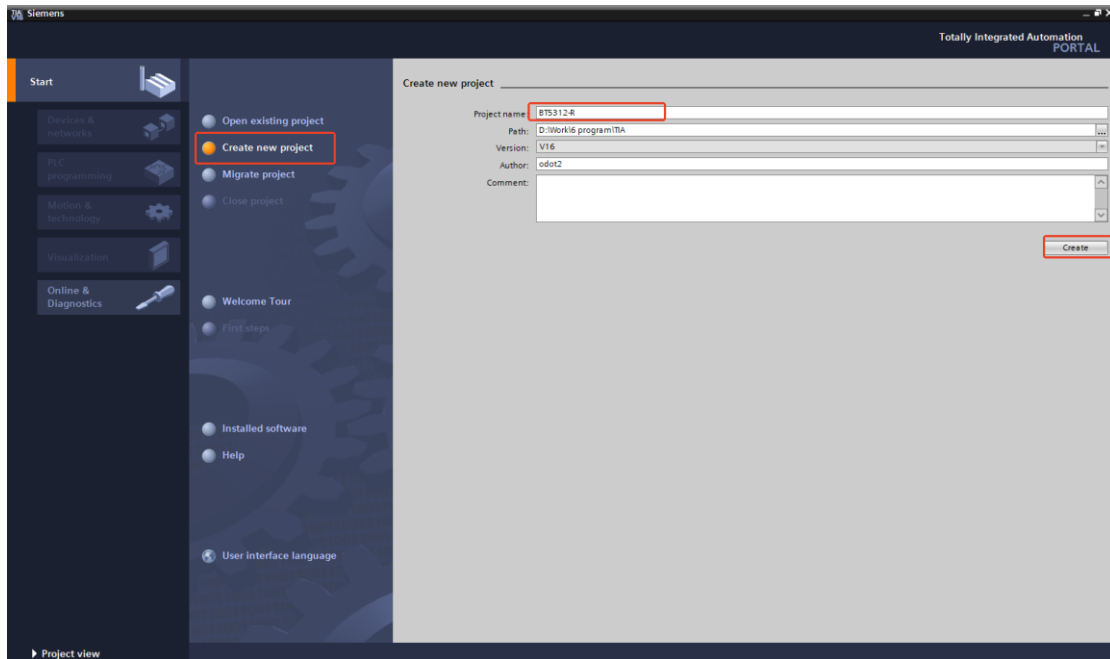

Click Add device, and then select “CPU 1212 DC/DC/DC 6ES7 212-1AE40-0XB0”, click OK.

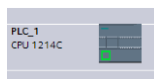
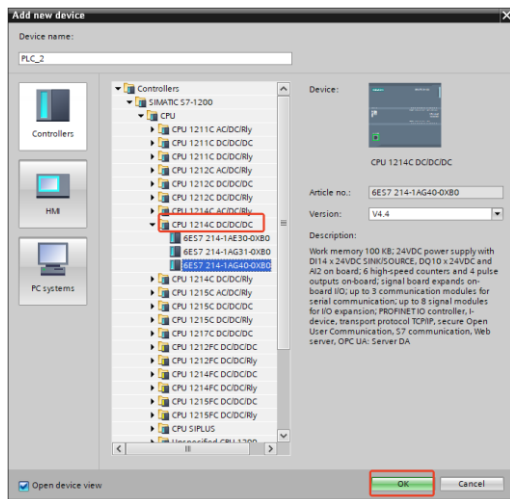

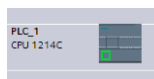
Click the , select the Ethernet address, set the IP address 192.168.1.10 and add a new subnet PN/IE_1.

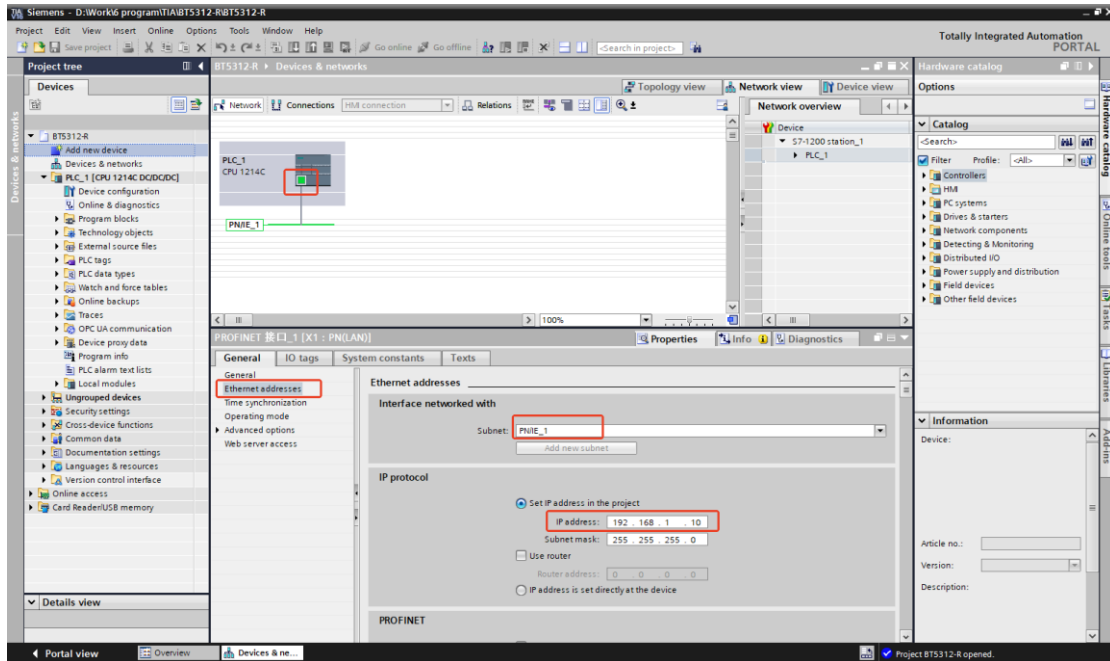

Add a new block in the block drop-down menu, and add data blocks DB1, DB2 and DB3. DB1 is used for S7-1200 to establish a connection with BN-8031, DB2 is used to store 4xxxx data, and DB3 is used to store 3xxxx data. (IP of BN-8031: 192.168.1.100), the IP address of the module can be viewed and modified through IO Config software).

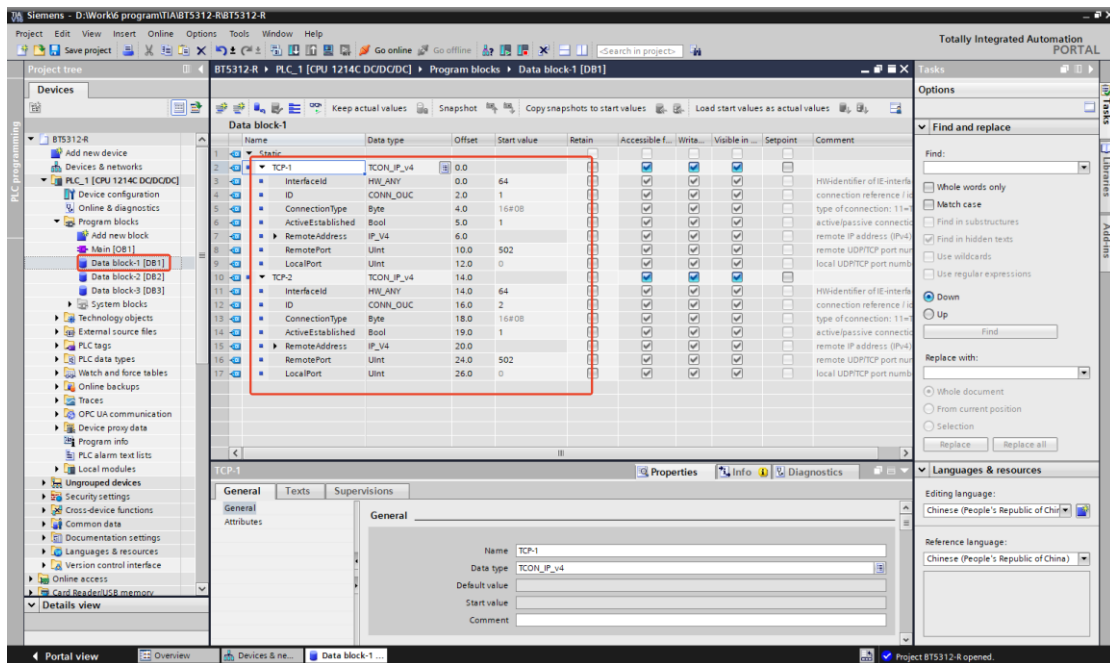

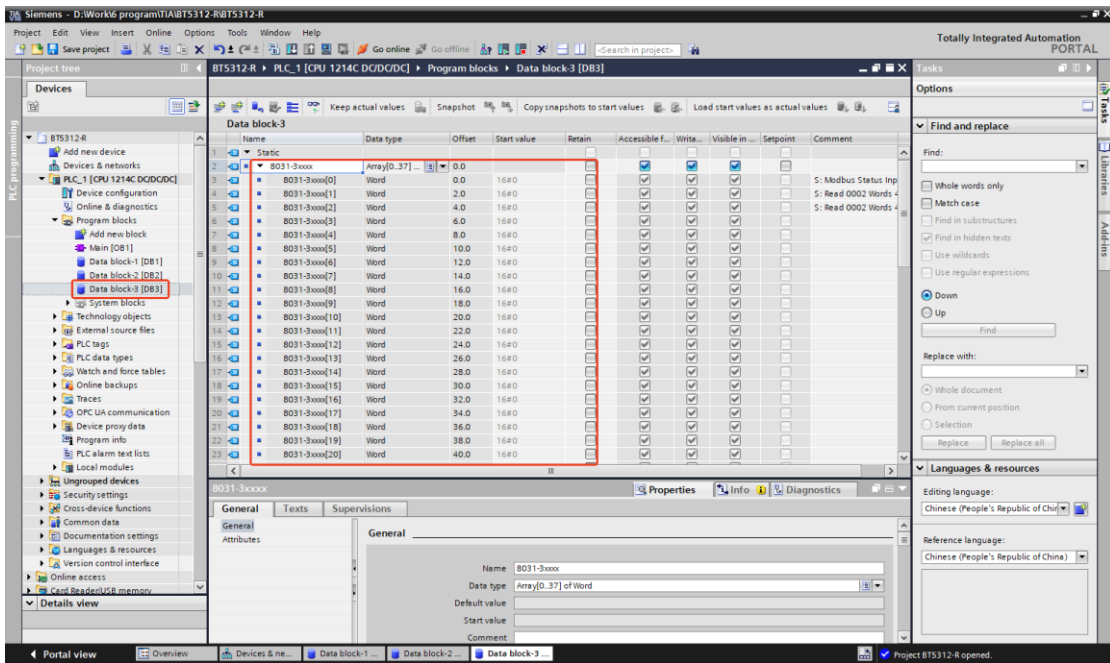
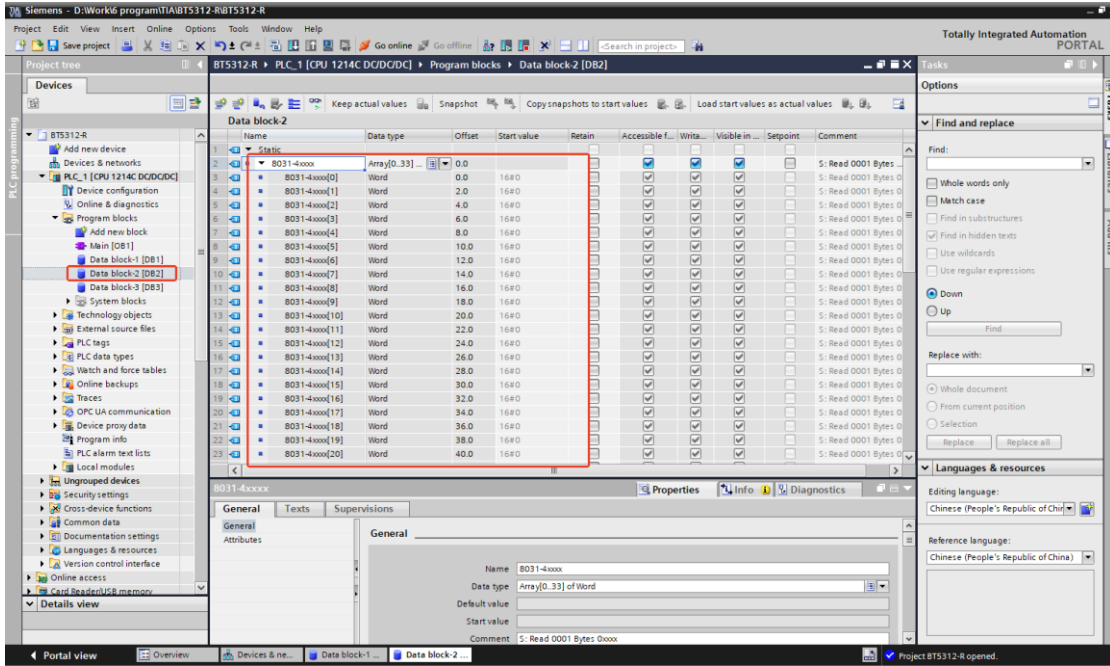

After a new block is created, each block needs to be compiled. Note: DB1, DB2, and DB3 right-click attributes, and remove the ✓ before accessing the optimized block.

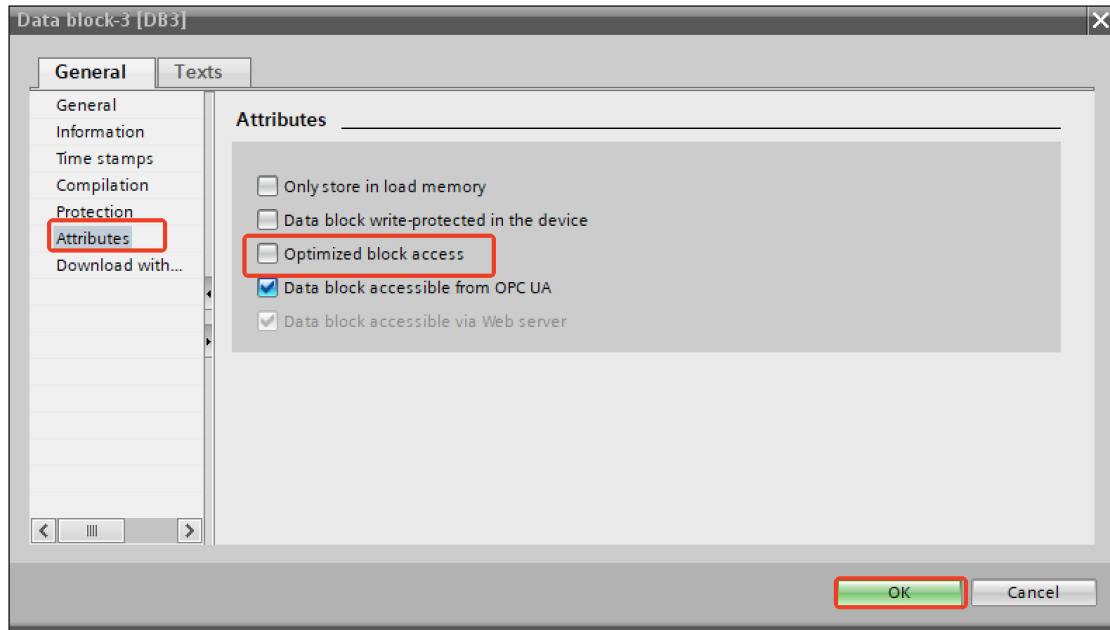

In the block drop-down menu, double-click Mian [OB1], find the command on the right MB_CLIENT drag it to section 1. Modify the parameters as shown in the figure.

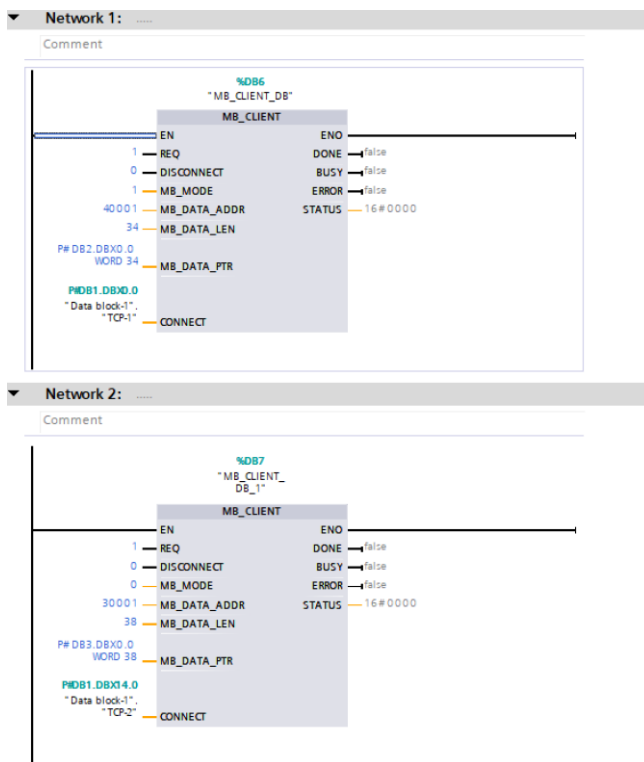

Once the setup is complete, save, compile, download, and go online after the download is complete.

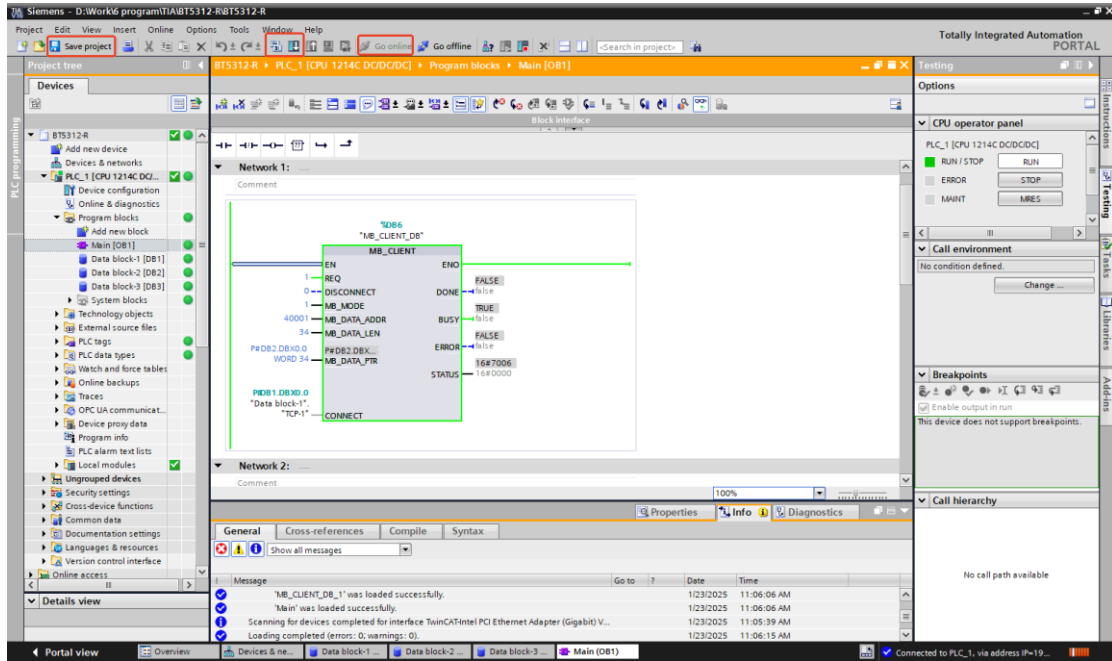

Using the Modbus Slave software to simulate RS485 devices, the field device values can be monitored online in the DB3 block, and the number of bytes sent and the data sent can be set in the DB2 block.

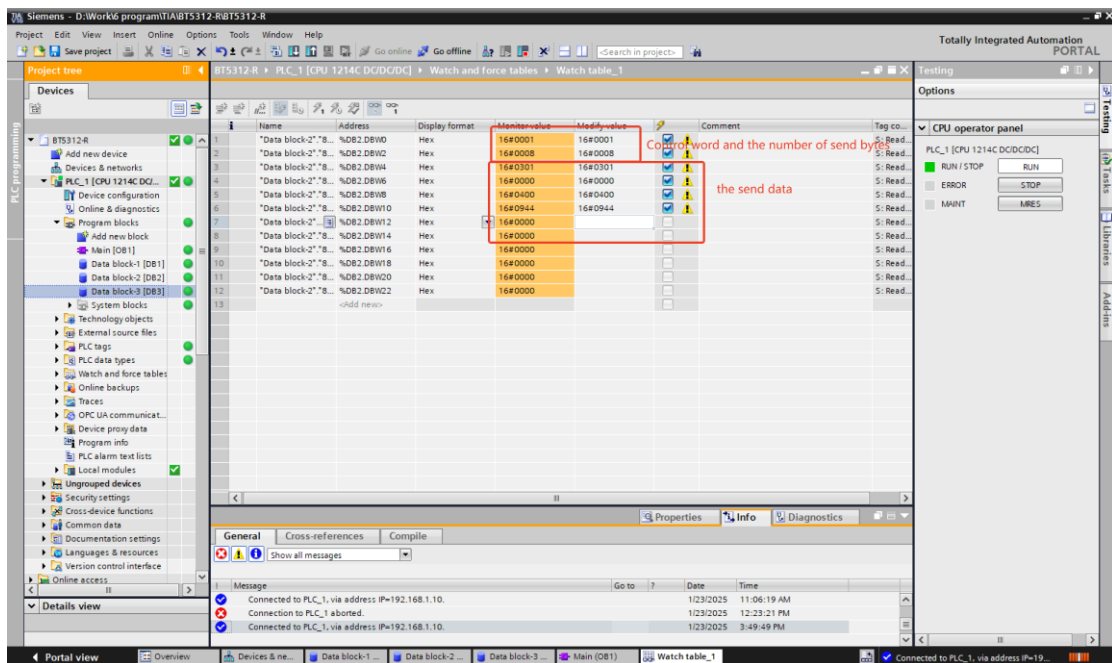

The screenshot displays the Siemens SIMATIC Manager interface. The main window shows the configuration for 'Data block-3' (DB3) in a PLC. The table below represents the data block structure:

Name	Data type	Offset	Start value	Monitor value
1	Static			
2	8031-3xxxx	Array[0..37]	0.0	16#0001 16#0008 16#0002 16#0000 16#0001 16#0000
3	8031-3xxxx	Word	0.0	16#0008
4	8031-3xxxx	Word	2.0	16#0002
5	8031-3xxxx	Word	4.0	16#0000
6	8031-3xxxx	Word	6.0	16#0001
7	8031-3xxxx	Word	8.0	16#0000
8	8031-3xxxx	Word	10.0	16#0301
9	8031-3xxxx	Word	12.0	16#0008
10	8031-3xxxx	Word	14.0	16#0008
11	8031-3xxxx	Word	16.0	16#004C
12	8031-3xxxx	Word	18.0	16#1458
13	8031-3xxxx	Word	20.0	16#1458
14	8031-3xxxx	Word	22.0	16#62DE
15	8031-3xxxx	Word	24.0	16#0014
16	8031-3xxxx	Word	26.0	16#0000
17	8031-3xxxx	Word	28.0	16#0000
18	8031-3xxxx	Word	30.0	16#0000
19	8031-3xxxx	Word	32.0	16#0000
20	8031-3xxxx	Word	34.0	16#0000
21	8031-3xxxx	Word	36.0	16#0000
22	8031-3xxxx	Word	38.0	16#0000
23	8031-3xxxx	Word	40.0	16#0000
24	8031-3xxxx	Word	42.0	16#0000
25	8031-3xxxx	Word	44.0	16#0000

Annotations in the image include 'input status' pointing to the first six rows and 'input data' pointing to the last six rows. A 'Modbus1' window is open, showing a table with an 'Alias' column containing '00000' and a list of values: '0x099C', '0x0D68', '0x1458', and '0x14DE'. A 'Communication Traffic' window is also visible, displaying hex data for Rx and Tx.

Example of communication between BT-5312 and BN-8032-L

BT-5312 is a serial port module, which can be used as a protocol converter with adapter BN-8032-L module to realize Modbus RTU/ASCII to Modbus TCP. PNM02 gateway.

Note: A maximum of 39 submodules can be added to a BT-5312, and when four BT-5312s are mounted on the BN-8032-L, the total number of submodules added to the four BT-5312 cannot exceed 120.

1 BT-5312 works in master mode

BT-5312 Modbus RTU Master topology map

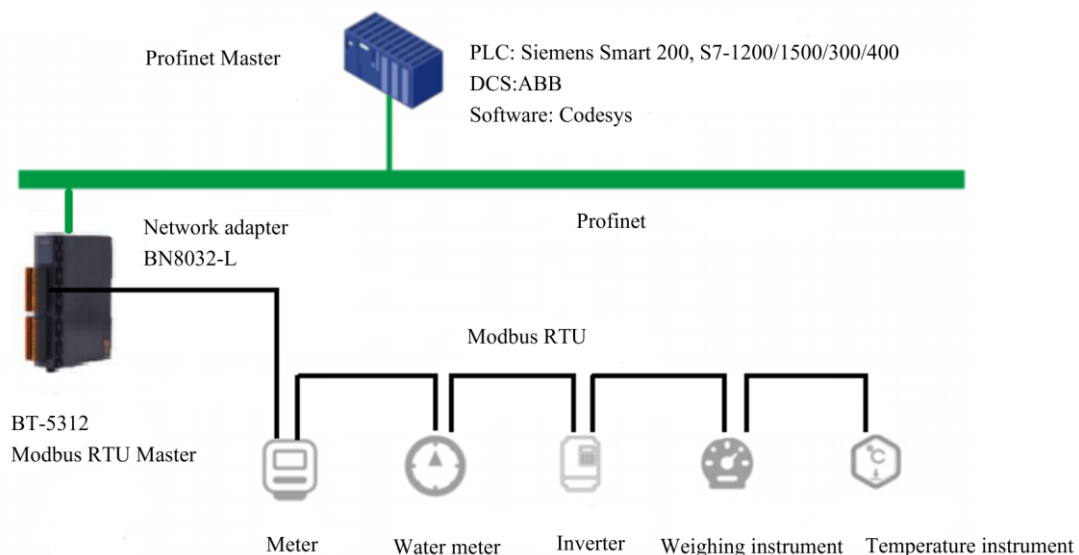

Note: It can configure the parameters without the IO Config. Configure parameters directly in the TIA/STEP7 software.

1. Hardware composition: BN-8032-L+BT-5312 with Siemens S7-1200 PLC.

In this chapter, the Siemens S7-1200 will be used as the controller of Profinet, TIA V16 will be used as the configuration software, and the Modbus Slave software will be used to simulate the RS485 device on the serial port, and the use of BN-8032-L and BT-5312 will be illustrated as an example. The S7-1200 and BN-8032-L modules are supplied with 24VDC respectively, and the network port of the S7-1200 is connected to the Port 2 of the BN-8032-L, and the Port 1 of the BN-8032-L is

connected to the PC for configuration. BT-5312 wiring A+B- to 485 to USB converter, USB serial port to PC.

2. Open the Siemens TIA V16 software, create a new project "BN8032L-BT5312", and click Create.

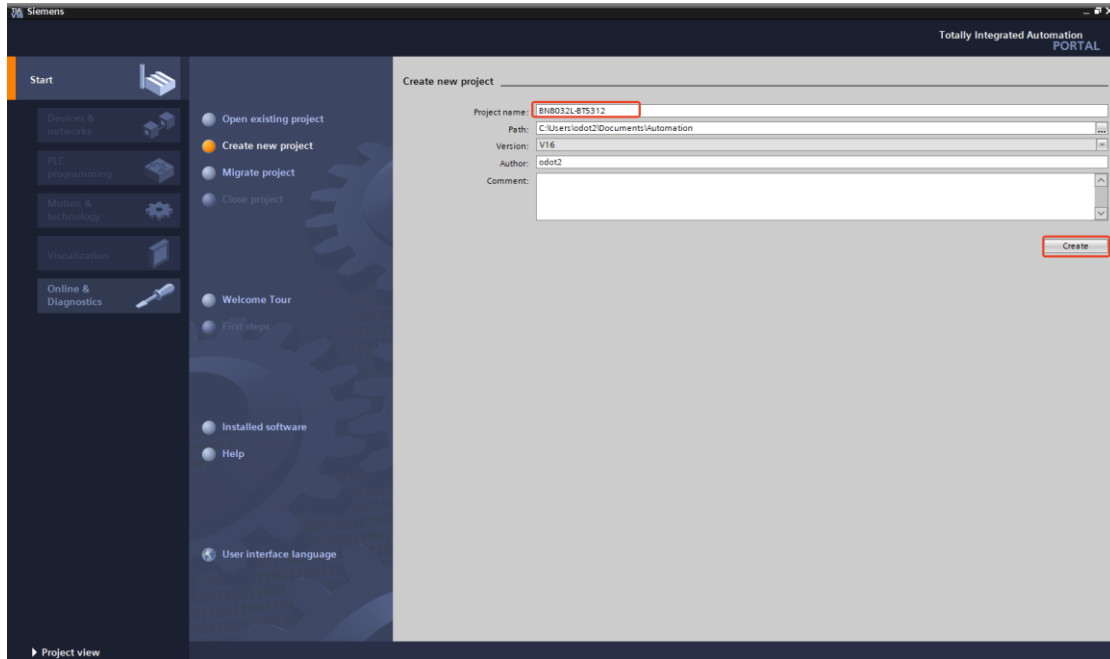

3. Enter the project view, click "Add New Device" under the "BN8032L-BT5312" project in the equipment column of the project tree, add PLC S7-1200 CPU 1214CDC/DC/DC, and click OK.

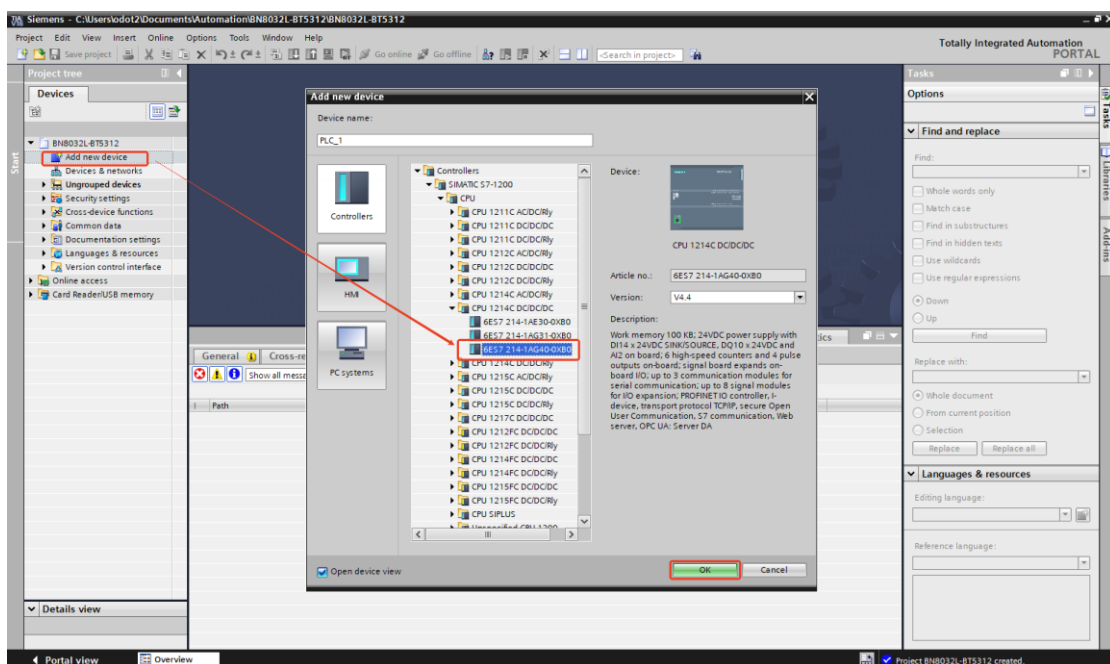

4. Click "Options - Manage general station description files (GSD)", in the pop-up interface, click "Source Path", load the "GSDML-V2.33-ODOT-BN8032-20240624" file, select the GSD file, and click Install.

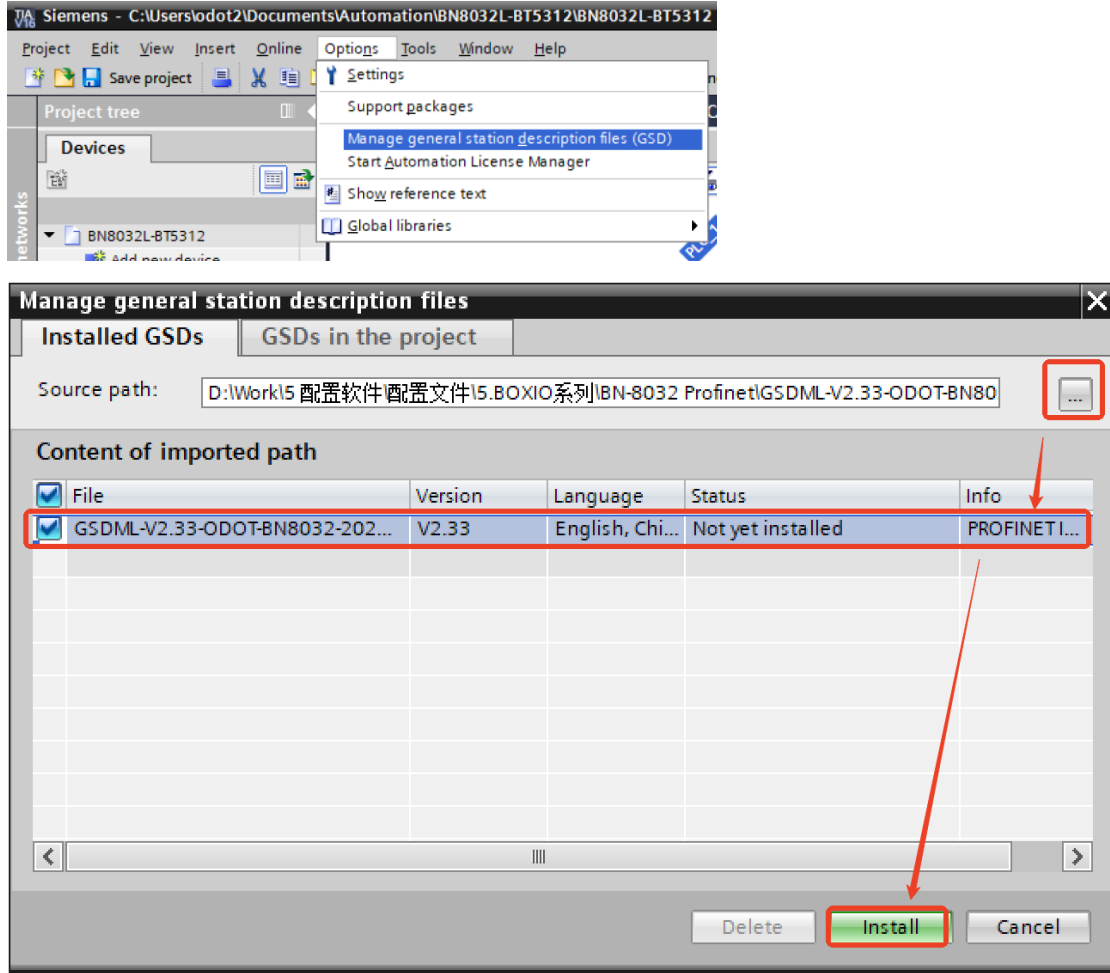

The following window pops up, indicating that the GSD file has been successfully installed, click "Close", and the hardware directory will be automatically updated after the installation is completed.

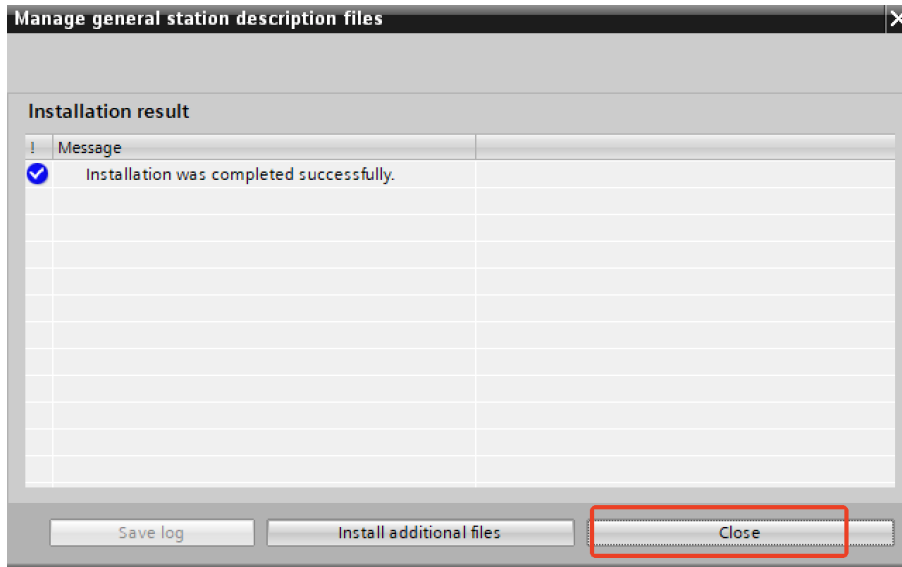

5. After successful installation, click on the directory “Other field devices—PROFINET IO—IO—ODOT—BOX IO System—B Series” , it can see BN-8032-L.

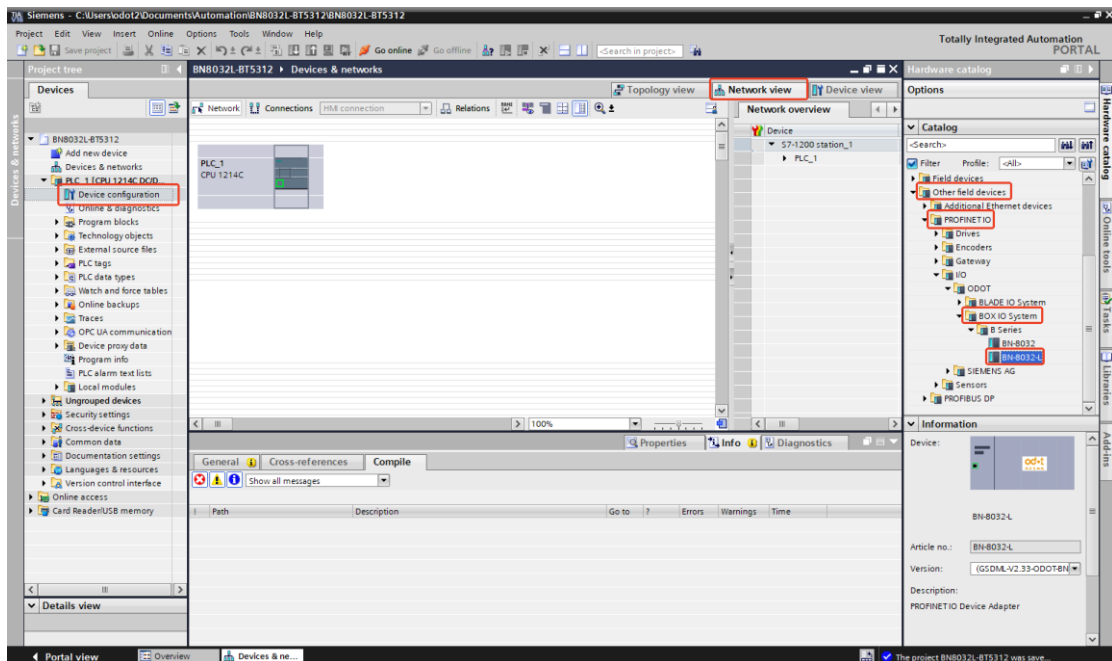

6. In the network view, select the PLC network port, select the Ethernet address in the properties, set the network port parameters, connect the interface to "PN/IE_1", and assign the IP address of the module to 192.168.0.1.

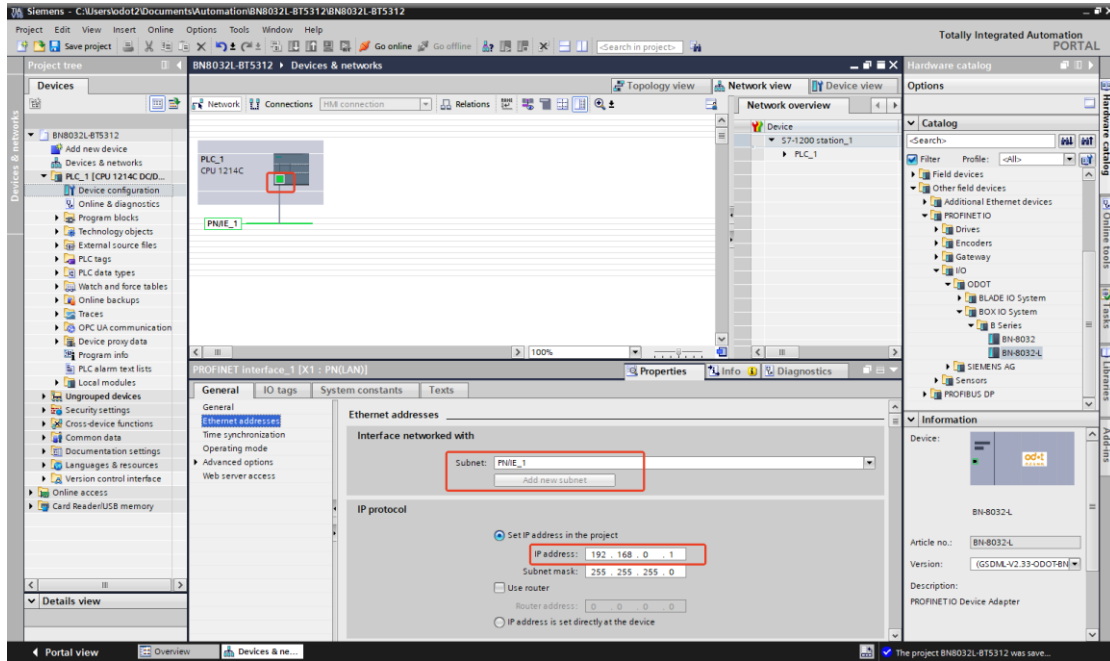

7. Select Online Access, click on the corresponding network card to the module connection, double-click Update Accessible Device, select "bn8032-addr", select Online and Diagnostics - Functions - Assign PROFINET Device Name - bn8032-1 - Assign name.

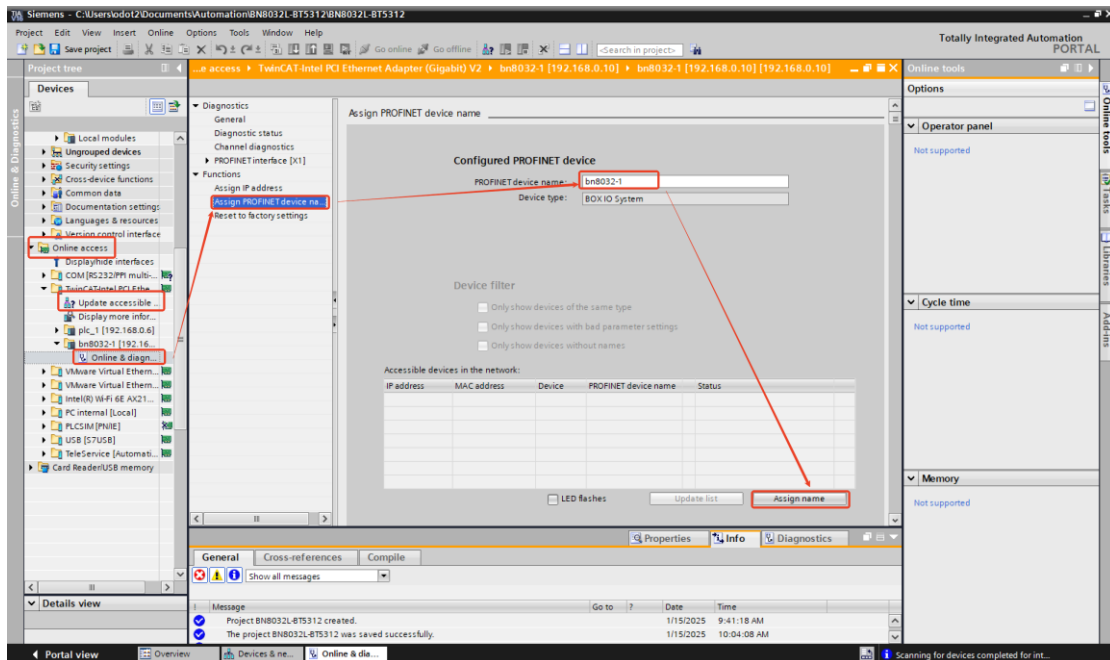

8. In the network view, first drag and drop the BN-8032-L module into the network view, and then assign the network interface to the "PLC_1. PROFINET IO-System", click the network port, modify the Ethernet parameters, and assign the IP address of

the module (192.168.0.2), and the PROFINET device name of the module is "bn8032-1".

Note 1: The device name of the module can be modified by online access, and the configured device name must be the same after the modification.

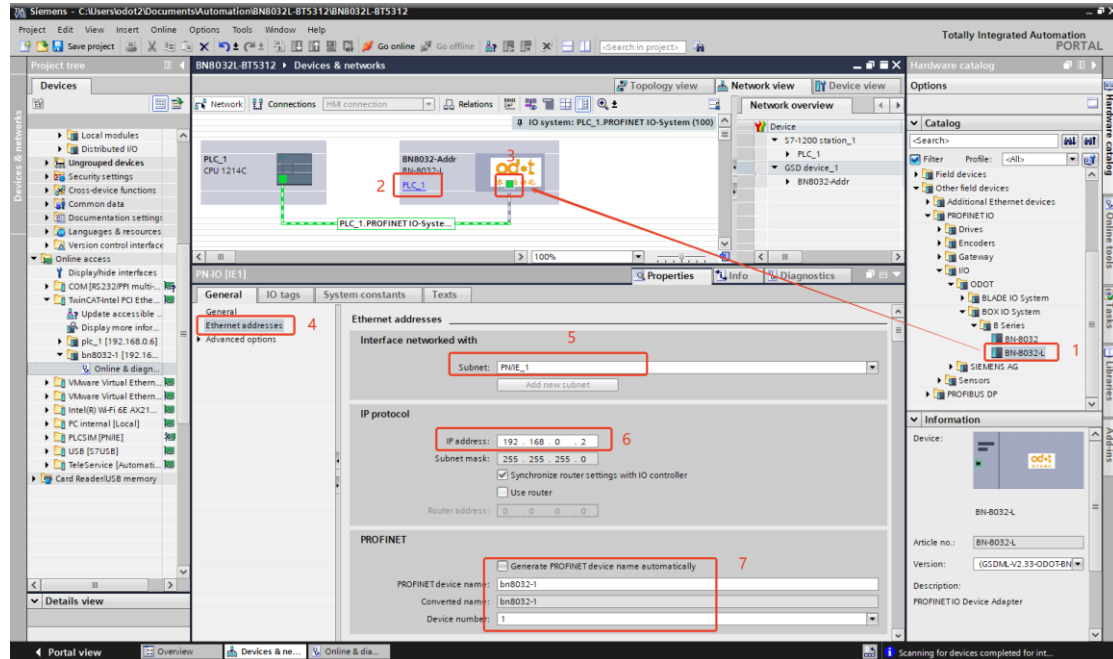

9. Double-click the  communication board icon to enter the "Device View", and add the extended IO module in the "Device Overview": BT-5312.

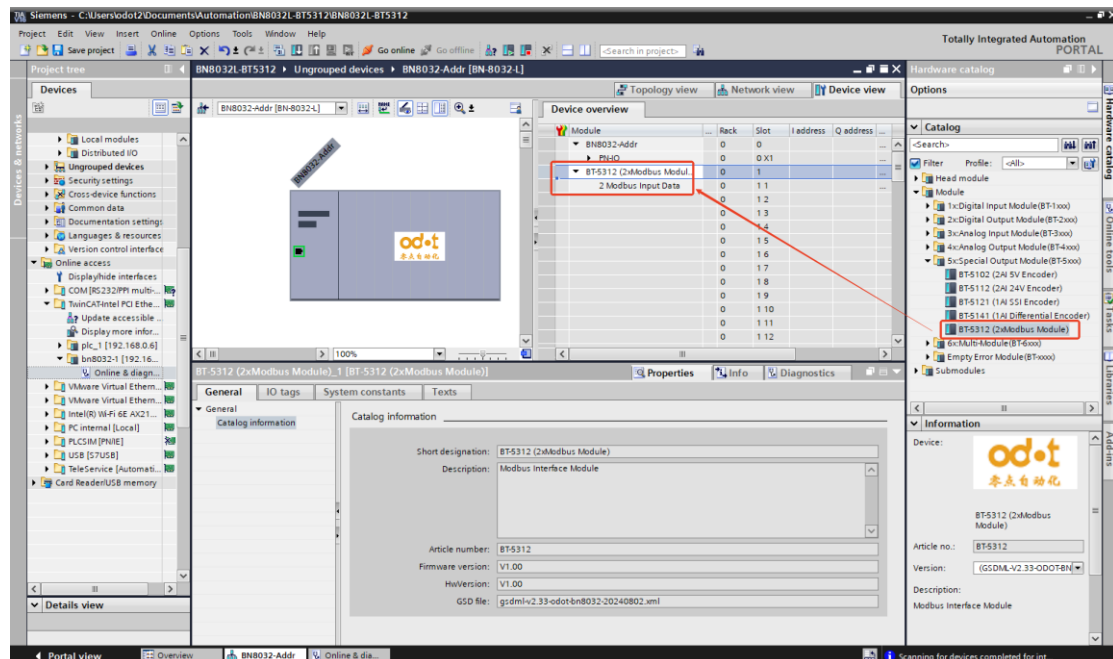

10. Select the communication module under the BT-5312 module, and it can view the

serial port parameters of the module in the properties. Set M/S/F working mode: Modbus master, 9600bps, N, 8, 1.

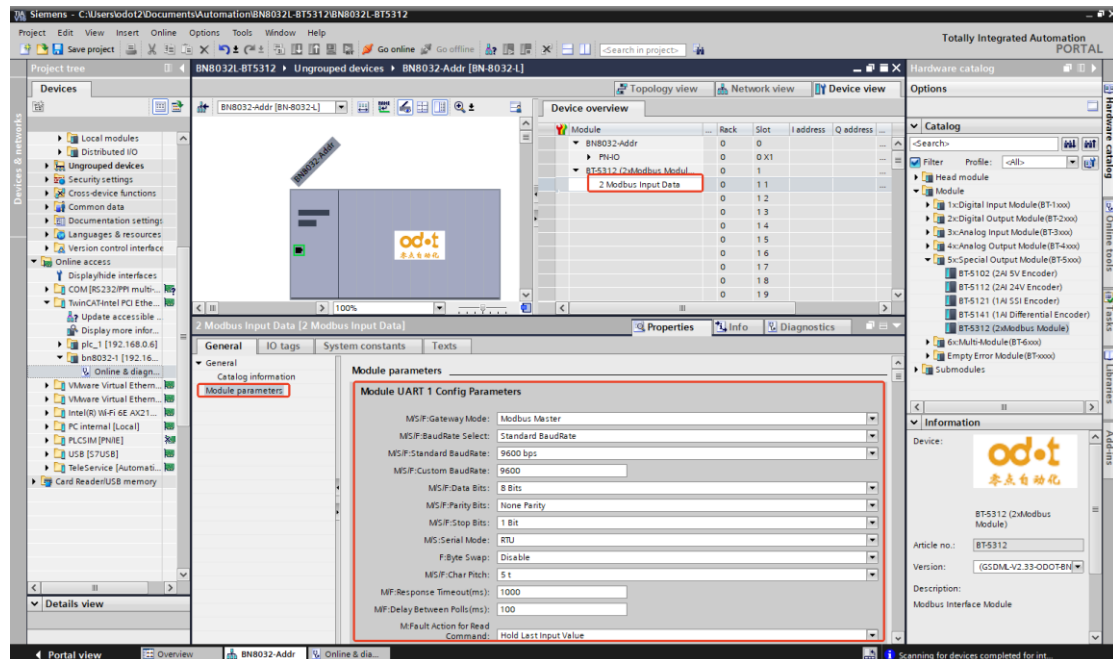

Parameters: M: indicates the command valid in master mode, S: indicates the command valid in slave mode, and F: indicates the command valid in free transparent transmission mode.

M/S/F: Working mode: Modbus master, Modbus slave, free port communication mode optional. Default Modbus master.

M/S/F: Baud rate selection: standard baud rate, custom baud rate optional. **Default standard baud rate.**

M/S/F: Standard baud rate: serial baud rate, 300-500000bps optional. **Default 9600bps.**

M/S/F: Custom baud rate: 300-500000bps optional. **Default 9600. Note: A small number of customers' devices are non-standard baud rate, which can be customized.**

M/S/F: Data bits: 7 bits, 8 bits optional, **default 8 bits.**

M/S/F: Check digits: none, odd, even, character, and space are optional, and there is **no check by default.**

M/S/F: Stop position: 1 bit, 2 bits, 1 bit.

M/S: Serial Mode: RTU/ASCII mode selectable, the **default RTU mode.**

F: Endian-order conversion: enabled, disabled, and **disabled by default**.

M/S/F: Character interval: the detection time of the frame interval when receiving the message, 1.5t~2000t optional, default **5t**. (t is the time it takes for a single character to be transmitted, which is related to the baud rate).

M/F: Response Timeout (ms): The time it takes for the master to wait for the slave to respond after sending the command. 1~65535 optional, **default 1000**.

M/F: Polling delay (ms): the interval between the sending of Modbus commands (the delay between receiving the slave response packet and sending the next command), 0~65535 optional, **Default is 100**.

M: Read command error handling mode: After the slave reads the data timeout, the data processing mode, keep the last input value, clear the input value is optional, and **the last input value is kept by default**.

M: Data output mode: polling, event triggering (data changes) are optional, and **polling is the default**. In "polling mode", Modbus periodically sends write packets. In Event-Triggered mode, write commands are sent only when the Modbus output data changes.

M: Module control enable: disabled, enabled optional, and disabled by default. When it needs to control the read and write commands of the Modbus, select the enable mode to control the read and write commands of the Modbus by controlling the value of the Module Control Output.

M: Module control mode: level trigger (continuous valid), rising edge trigger (single trigger) optional, **default level trigger (continuous valid)**. **This value is only valid in module control enable mode**

M: Power-on event output: enable, disable, and **enable by default**.

S: Slave ID: 1-247 can be set. This parameter is valid only in slave mode.

S: Response delay (ms): 0~65535 Optional, **default 0**

After adding the BT-5312 serial port module, the submodule will appear in the hardware directory, select the corresponding read and write command.

Note: M: indicates the command valid in master mode, S: indicates the command valid in slave mode, and F: indicates the command valid in free transparent transmission mode.

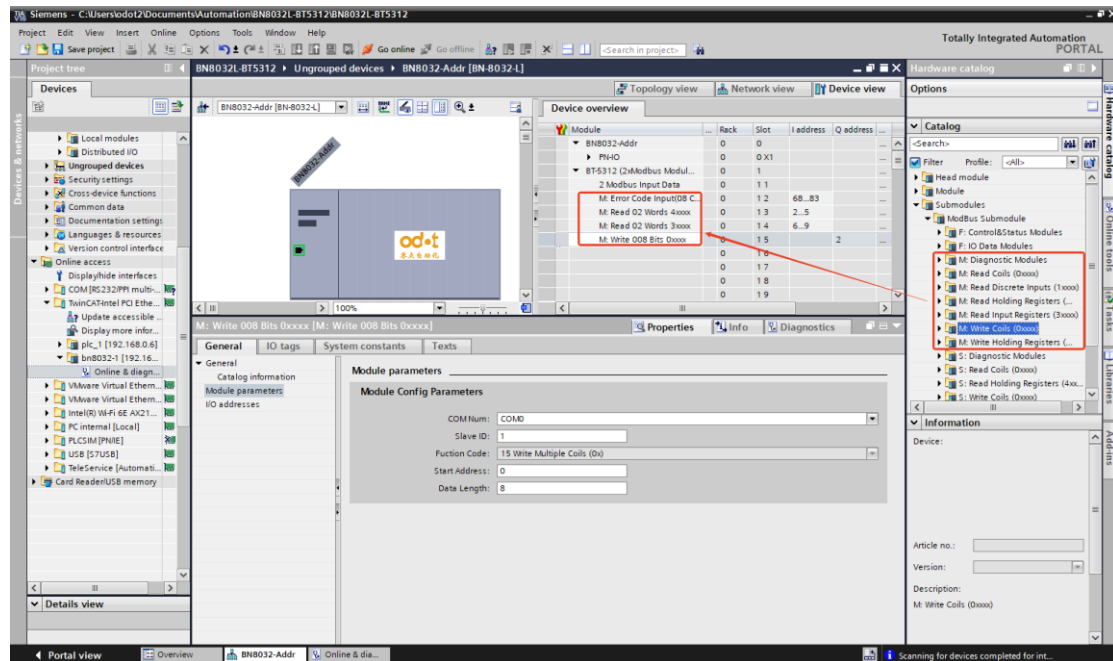

Select the individual read and write commands, and configure the slave ID number and start address in the module parameters.

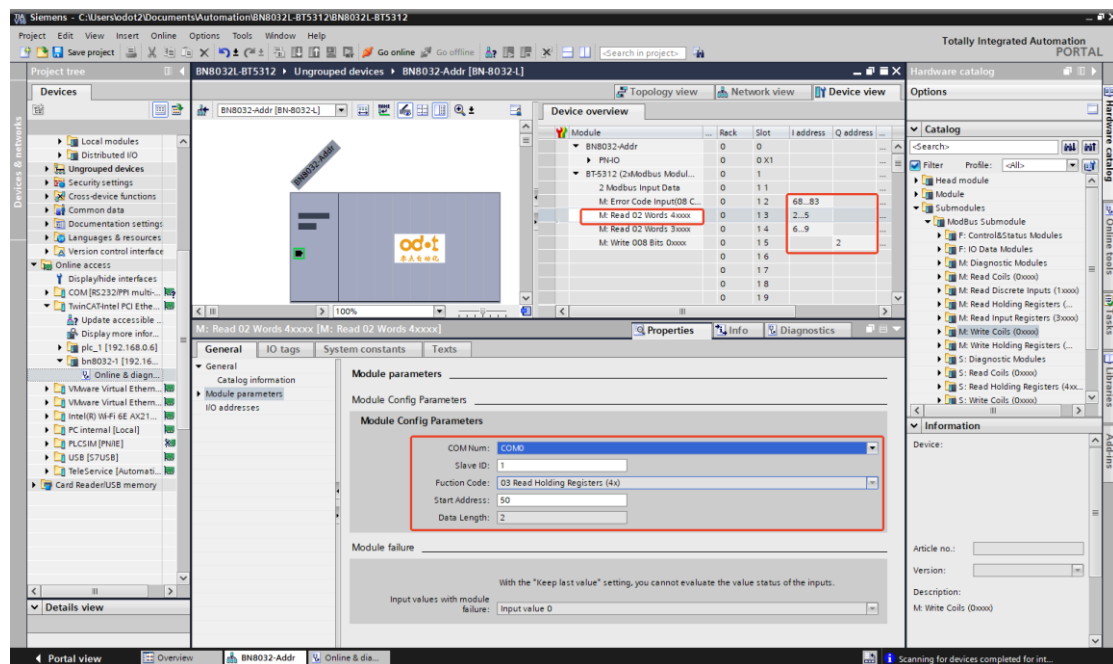

11. The hardware configuration is completed, and it is saved, compiled and downloaded. Click "Go Online".

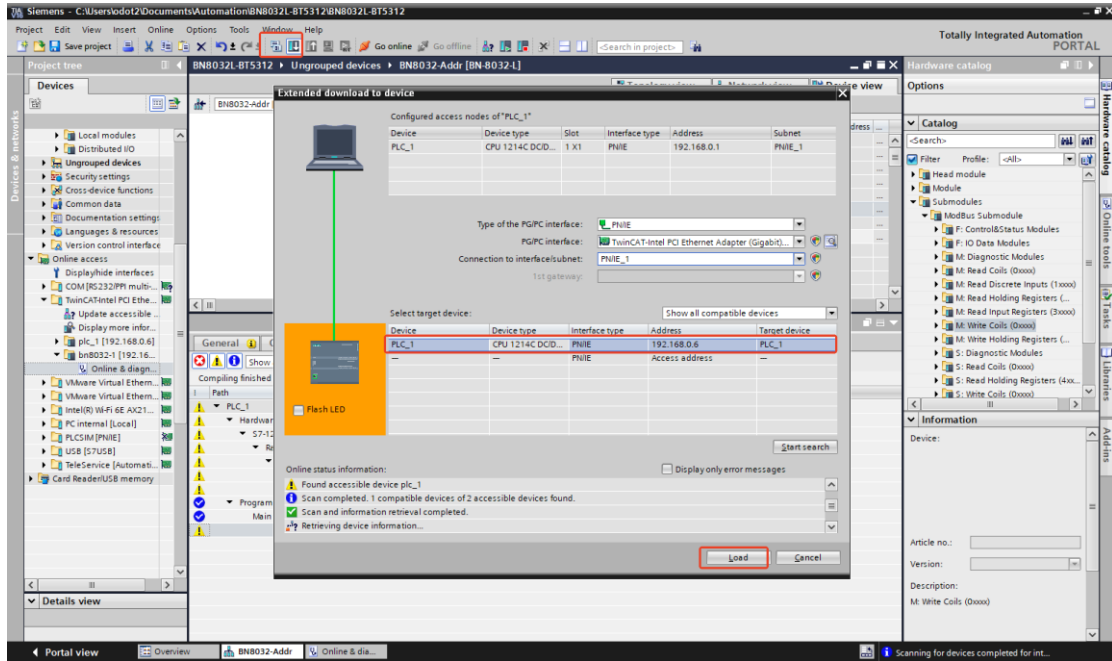

12. At the same time, a new monitoring table can be added to monitor the value of field devices online on the monitoring table. Use Modbus Slave to emulate RS485 devices.

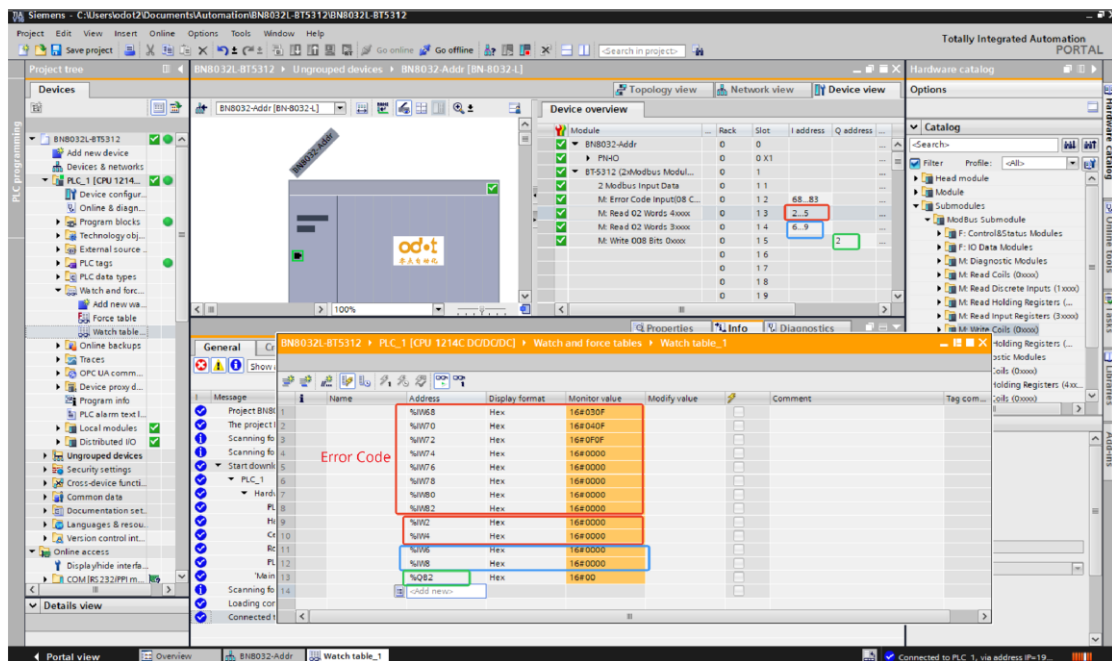

The screenshot displays the Siemens SIMATIC Manager interface, divided into several key sections:

- Modbus Slave Configuration:** Three windows (Mbslave1, Mbslave2, Mbslave3) show the configuration for three separate Modbus slaves. Each window includes a table for defining slave addresses and data ranges.

Alias	Start Address	End Address
0	0x0237	0x0342

Alias	Start Address	End Address
0	0x0D57	0x0ADF

Alias	Start Address	End Address
0	00000	1
1	0	0
2	0	0
3	0	0
4	0	0
5	0	0
6	0	0
7	0	0
8	0	0
9	0	0
- Watch Table:** A table in the main window defines the mapping between PLC addresses and Modbus addresses.

Name	Address	Display format	Monitor value	Modify value	Comment
%W68	Hex	16#0000			
%W70	Hex	16#0000			
%W72	Hex	16#0000			
%W74	Hex	16#0000			
%W76	Hex	16#0000			
%W78	Hex	16#0000			
%W80	Hex	16#0000			
%W82	Hex	16#0000			
%W2	Hex	16#0237			
%W4	Hex	16#0342			
%W6	Hex	16#0D57			
%W8	Hex	16#0ADF			
%Q82	Hex	16#03		16#03	
- Message Log:** A list of system messages at the bottom, including project creation, device scanning, and hardware configuration steps.

2 BT-5312 Works in slave mode

BT-5312 Modbus RTU Slave topology map

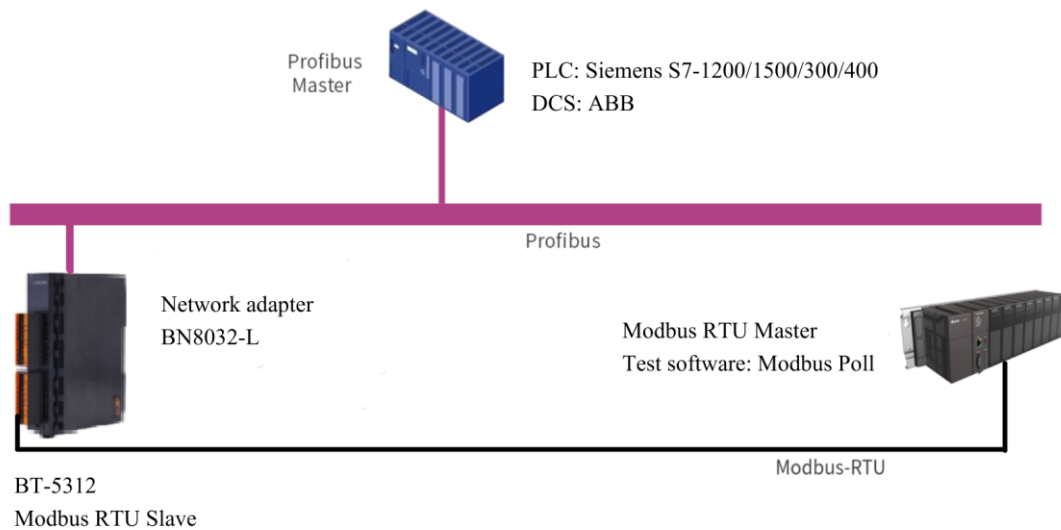

Note: It can configure the parameters without the IO Config. Configure parameters directly in the TIA/STEP7 software.

1. Hardware composition: BN-8032-L+BT-5312 with Siemens S7-1200 PLC.

In this chapter, the Siemens S7-1200 will be used as the controller of Profinet, TIA V16 will be used as the configuration software, and Modbus Poll software will be used to simulate the RS485 device on the serial port, and the use of BN-8032-L and BT-5312 will be illustrated as an example. The S7-1200 and BN-8032-L modules are supplied with 24VDC respectively, and the network port of the S7-1200 is connected to the Port 2 of the BN-8032-L, and the Port 1 of the BN-8032-L is connected to the PC for configuration. BT-5312 wiring A+B- to 485 to USB converter, USB serial port to PC.

2-9 refers to BT-5312 working in master mode 2-9.

10. Select the communication module under the BT-5312 module, and it can view the serial port parameters of the module in the properties. Set M/S/F working mode: Modbus slave, 9600bps, N, 8, 1, slave ID: 1. Select S: commands.

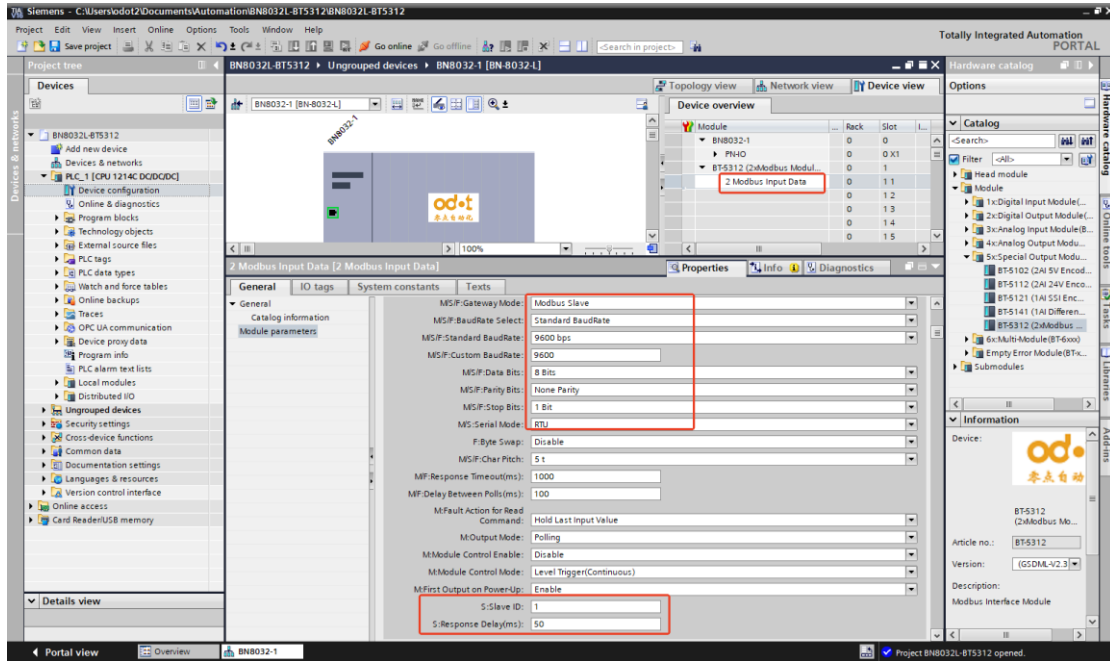

Select the read and write command and configure the module parameter serial port number and start address.

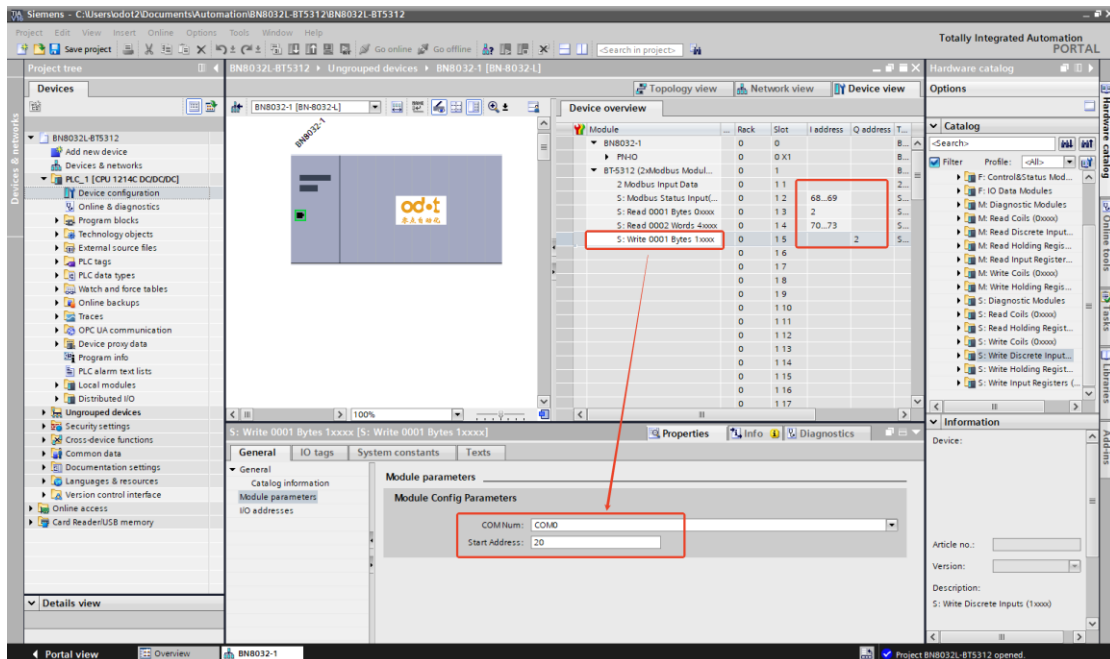

11. The hardware configuration is completed, and it is saved, compiled and downloaded. Click "Go Online".

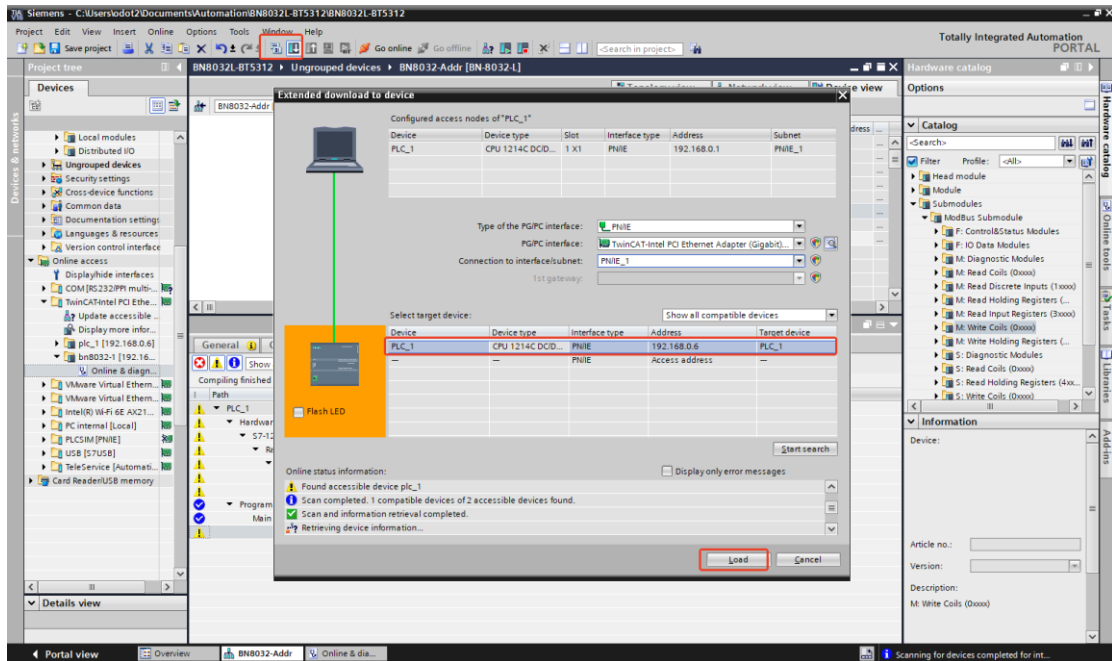

12. At the same time, a new monitoring table can be added to monitor the value of field devices online on the monitoring table. Use Modbus Poll to simulate RS485 devices.

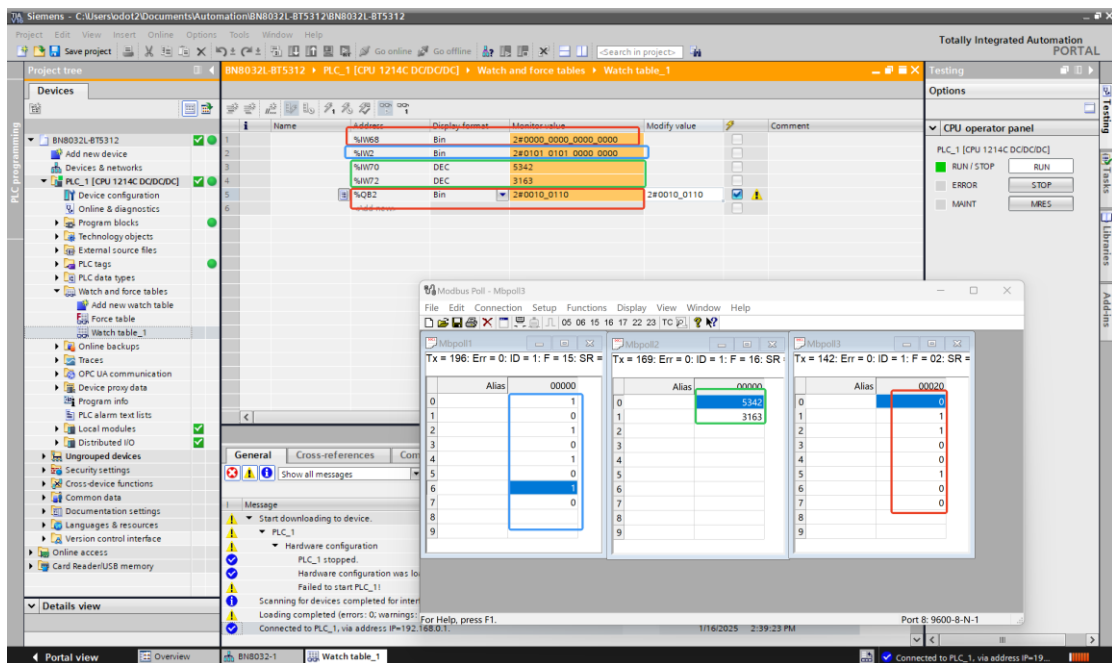

3 BT-5312 Works in free port communication mode

3.1 Report mode

Note: It can configure the parameters without the IO Config. Configure parameters directly in the TIA/STEP7 software.

1. Hardware composition: BN-8032-L+BT-5312 with Siemens S7-1200 PLC.

In this chapter, the Siemens S7-1200 will be used as the controller of Profinet, TIA V16 will be used as the configuration software, and the Serial Port Utility software and Modbus slave software will be used to simulate the RS485 device on the serial port side, and the use of BN-8032-L and BT-5312 will be illustrated as an example. The S7-1200 and BN-8032-L modules are supplied with 24VDC respectively, and the network port of the S7-1200 is connected to the Port 2 of the BN-8032-L, and the Port 1 of the BN-8032-L is connected to the PC for configuration. BT-5312 wiring A+B- to 485 to USB converter, USB serial port to PC.

2-9 refers to BT-5312 working in master mode 2-9.

10. Select the communication module under the BT-5312 module, and it can view the serial port parameters of the module in the properties. Set the M/S/F working mode: free port communication mode, 9600bps, N, 8, 1, select F: for read and write commands.

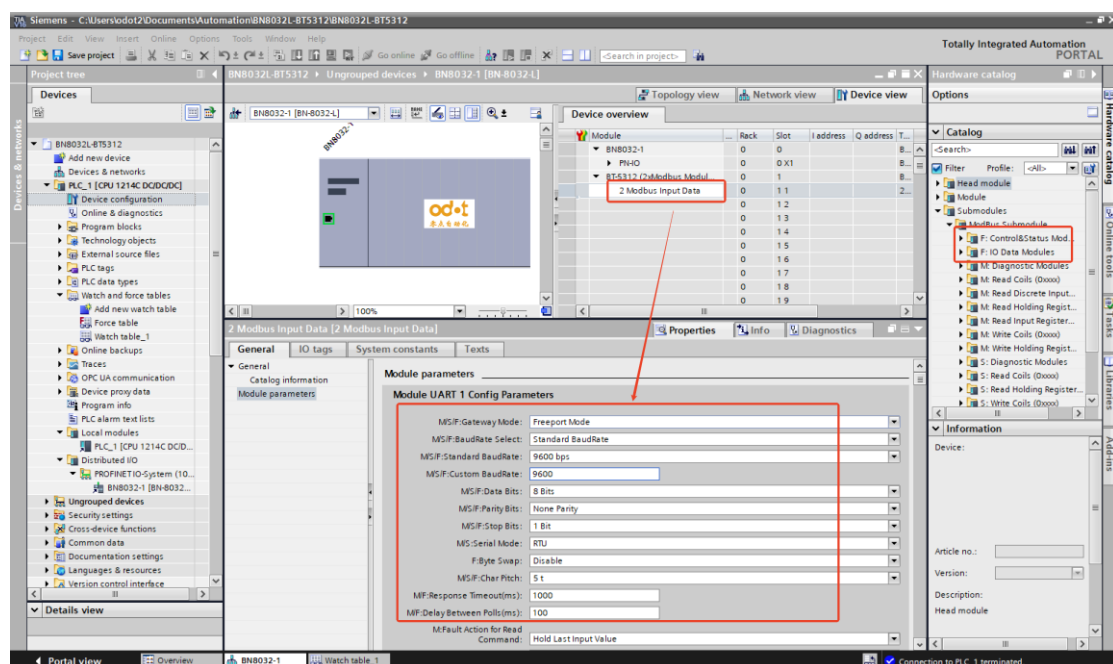

Select the Control Status module and configure the serial number and communication mode: Report.

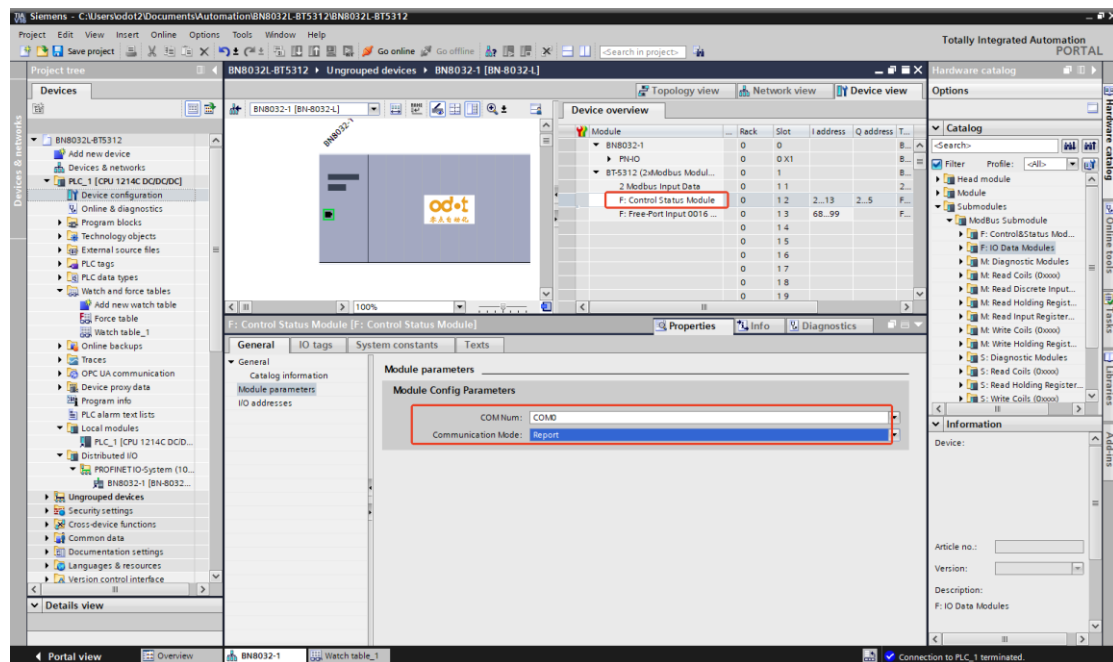

11. The hardware configuration is completed, and it is saved, compiled and downloaded. Click "Go Online".

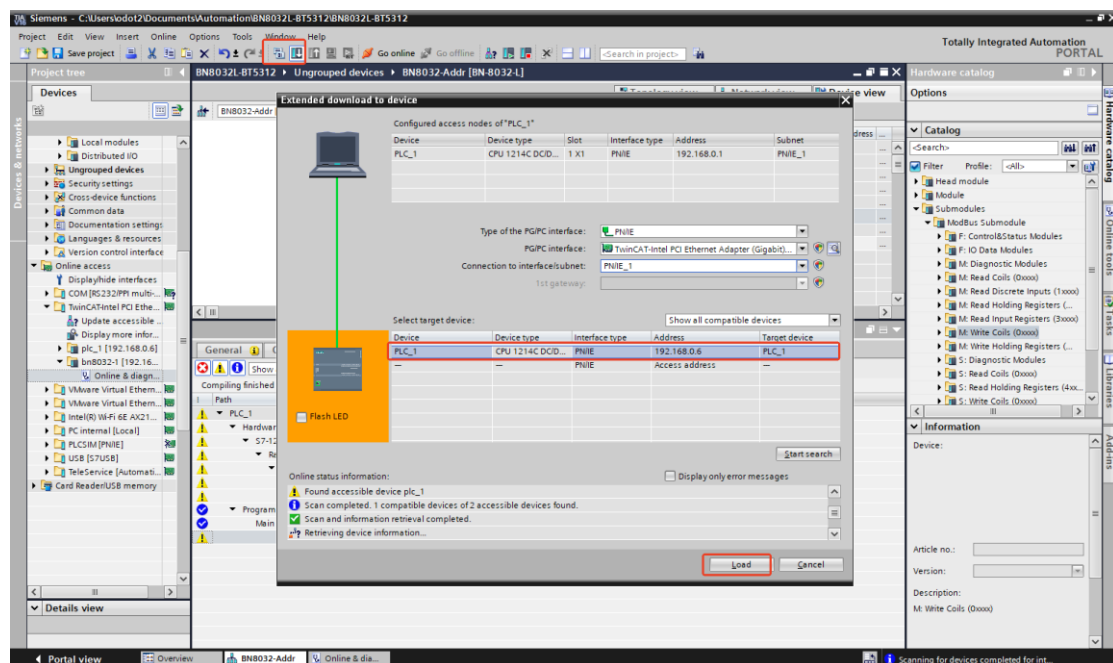

12. At the same time, a new monitoring table can be added to monitor the value of field devices online on the monitoring table. Use serial port utility software to emulate RS485 devices. The 6 words starting from the IW2 are the status bit data, and the

input data starting from IW68 is the stored input data.

The screenshot displays the Siemens TIA Portal interface. The main window shows a 'Watch table' configuration for a PLC. The table has the following columns: Name, Address, Display format, Monitor value, Modify value, and Comment. The data is as follows:

Name	Address	Display format	Monitor value
%IW2	1640000	Hex	1640000
%IW4	1640000	Hex	1640000
%IW6	1640000	Hex	1640000
%IW8	1640000	Hex	1640000
%IW10	16402F9	Hex	16402F9
%IW12	1640000	Hex	1640000
%QW2	1640000	Hex	1640000
%QW4	1640000	Hex	1640000
%IW68	1640000	Character	'D'
%IW70	1640000	Character	'I'
%IW72	1640000	Character	'M'
%IW74	1640000	Character	'O'
%IW76	1640000	Character	'V'
%IW78	1640000	Character	'3'
%IW80	1640000	Character	'5000'
%IW82	1640000	Character	'500500'
%IW84	1640000	Character	'500500'
%IW86	1640000	Hex	1640000
%IW88	1640000	Hex	1640000
%IW90	1640000	Hex	1640000
%IW92	1640000	Hex	1640000

A 'Serial Port Utility' dialog box is open, showing the 'Serial Port Setting' for a COM8 port. The 'Send Setting' is set to 'Text'. The 'Send' field contains the value '0017M0213.0', which is highlighted with a red box. A red arrow points from this box to the 'Monitor value' column of the '%IW76' row in the watch table above.

3.2 Request-Response mode

Note: In the Request-Response mode (for output commands), the Trigger rising edge to trigger a serial port data send, and the serial port will send the data packet at the data length of Send_Data_Len and wait for the reply to be processed.

1-8 refer to BT-5312 working in master mode 1-8.

9. Select the control status module, and configure the COM number and communication mode: request-response mode.

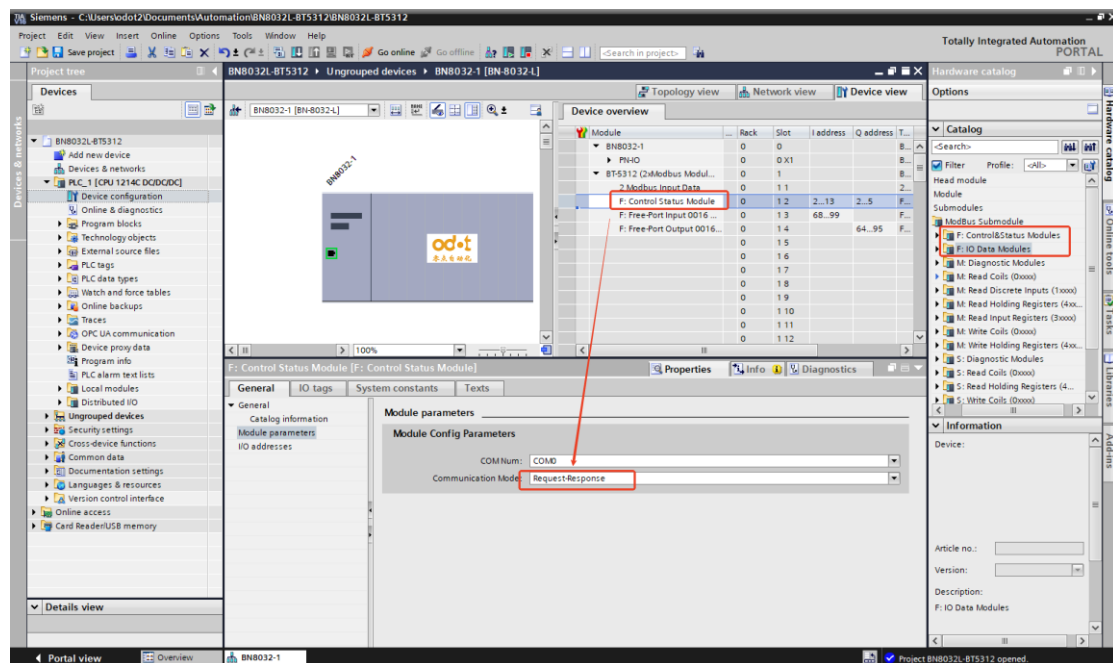

10. The hardware configuration is completed, and it is saved, compiled and downloaded. Click "Go Online".

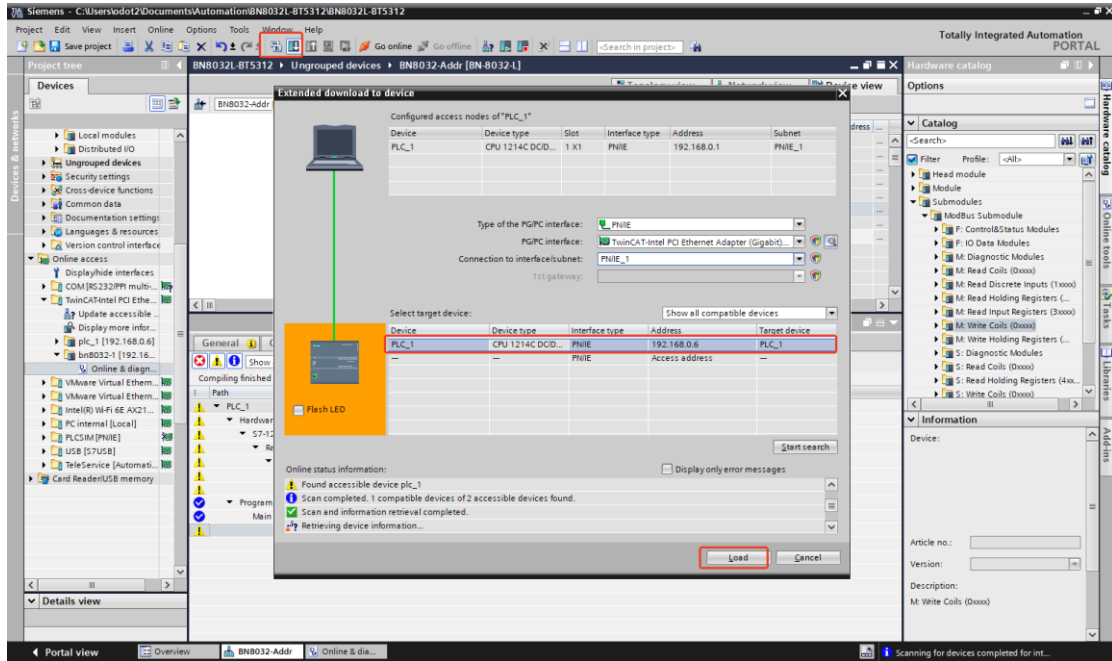

11. At the same time, a new monitoring table can be added to monitor the value of field devices online on the monitoring table. RS485 device is simulated using Modbus slave software. IW2~IW12 are the status word data, QW2 and QW4 are the control word data, from the IW68 are the slave response data, and from the QW64 are the output request data.

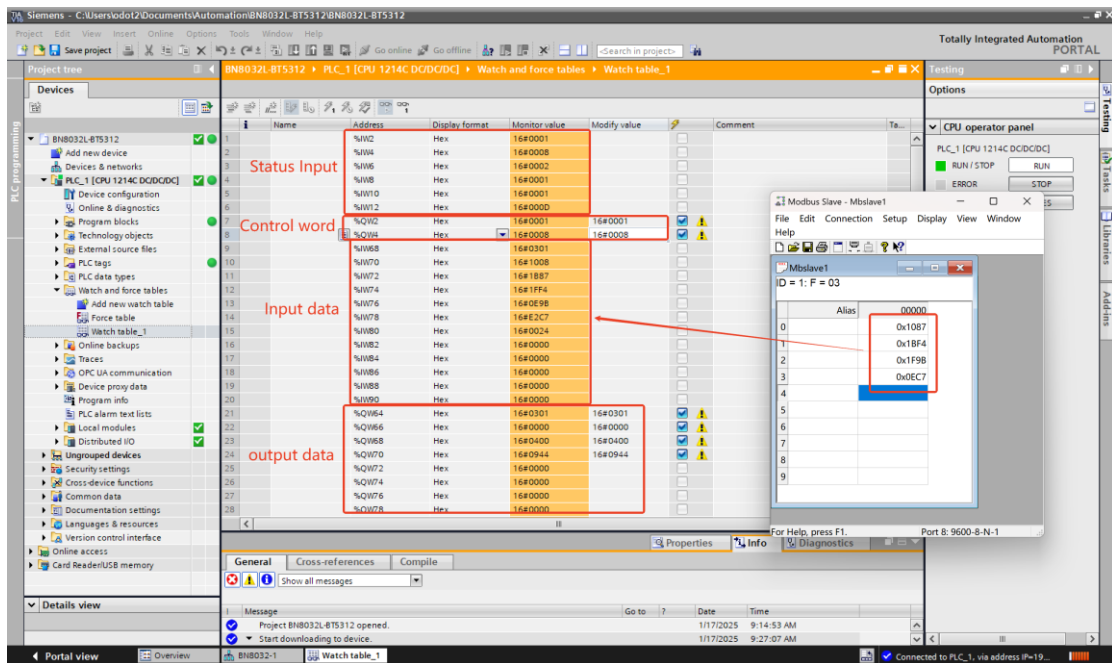

Communication Traffic

Exit Stop Clear Save Copy Log Time stamp

Rx:000001-01 03 00 00 00 04 44 09
Tx:000002-01 03 08 10 87 1B F4 1F 9B 0E C7 E2 24

Example of communication between BT-5312 and BN-8033

BT-5312 is a serial port module, which can be used as a protocol converter with the adapter BN-8033 module to realize Modbus RTU/ASCII to Ethercat, and the serial port side supports master, slave, and free transparent transmission modes.

3.1 BT-5312 works in master mode

BT-5312 Modbus RTU Master topology map

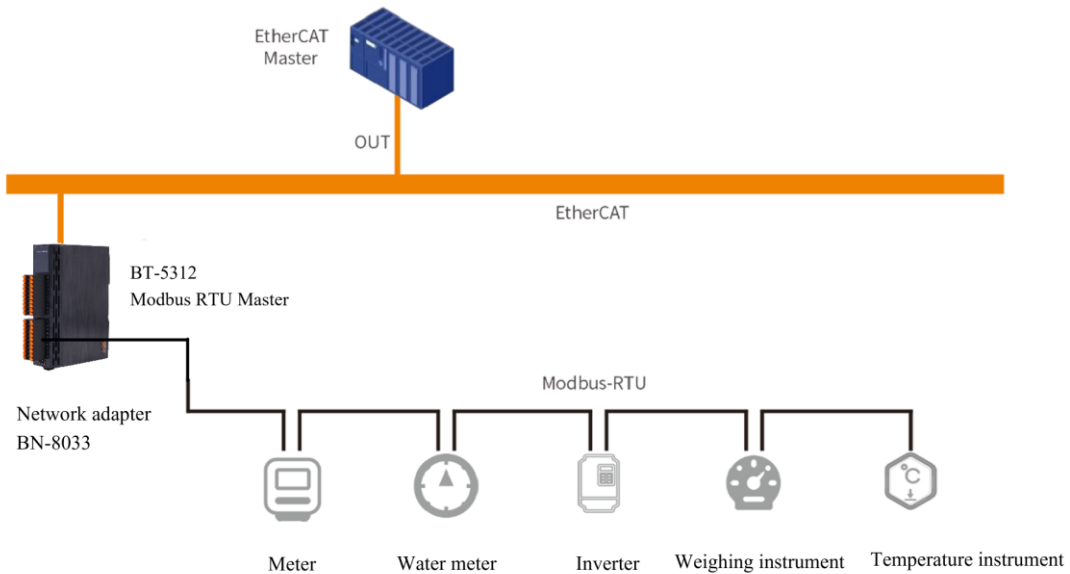

Note: 1. It needs to use IO Config to set parameters.

2. If not using the latest version of IO Config, it needs to update the device description file (hardware support package) or install the latest version of IO Config.

Hardware Composition: BN-8033 and BT-5312

Power the BN-8033 module to 24VDC system power supply and field power supply, the network cable is directly connected to the EtherCAT IN interface between the PC and the BN-8033 (**EtherCAT communication strictly distinguishes input and output, and the interface cannot be connected wrongly, otherwise the module communication may be abnormal**), BT-5312 wiring A+ B-Connect to a 485 to USB converter, and connect the USB serial port to a PC.

1. Set the parameters of BN-8033 and BT-5312

Use a Micro USB cable to connect the PC to the BN-8033 configuration interface, and the com port will be generated in the computer device manager. Open the IO Config

software and click File to create a new project. After creating a new project, select "Serial Port" in the upload interface in the attribute bar, select "COM12" for the COM number, and right-click the project to upload the module to upload the BN-8033 module.

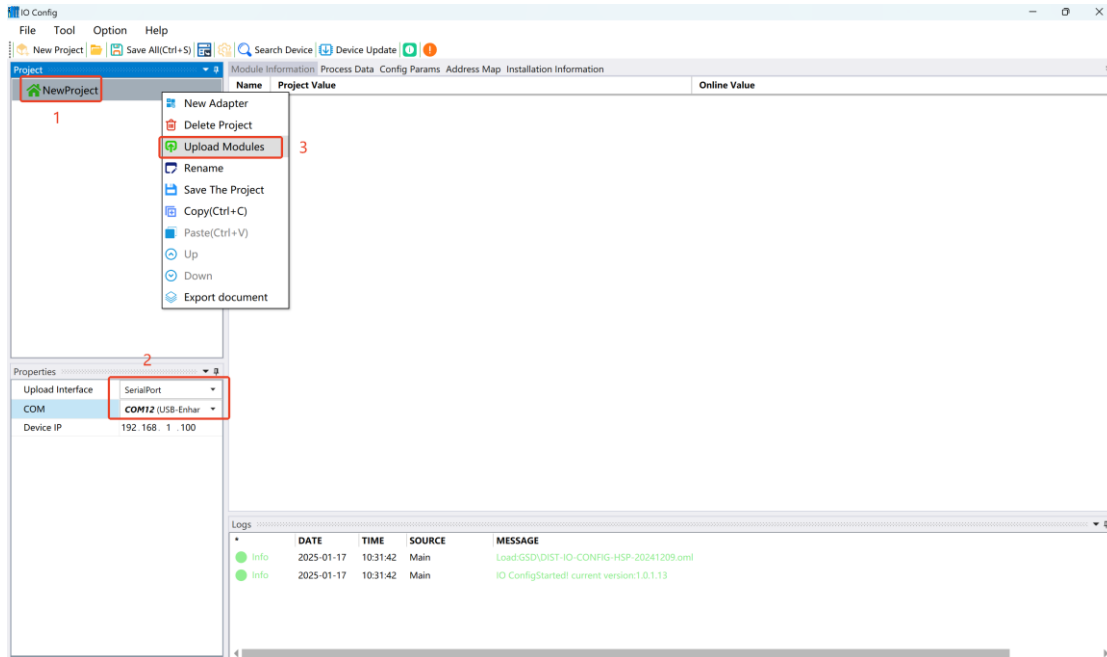

Select the BT-5312 module, click Config Params, it can configure the parameters of the module, working mode: Modbus master, 9600bps, N, 8, 1, RTU.

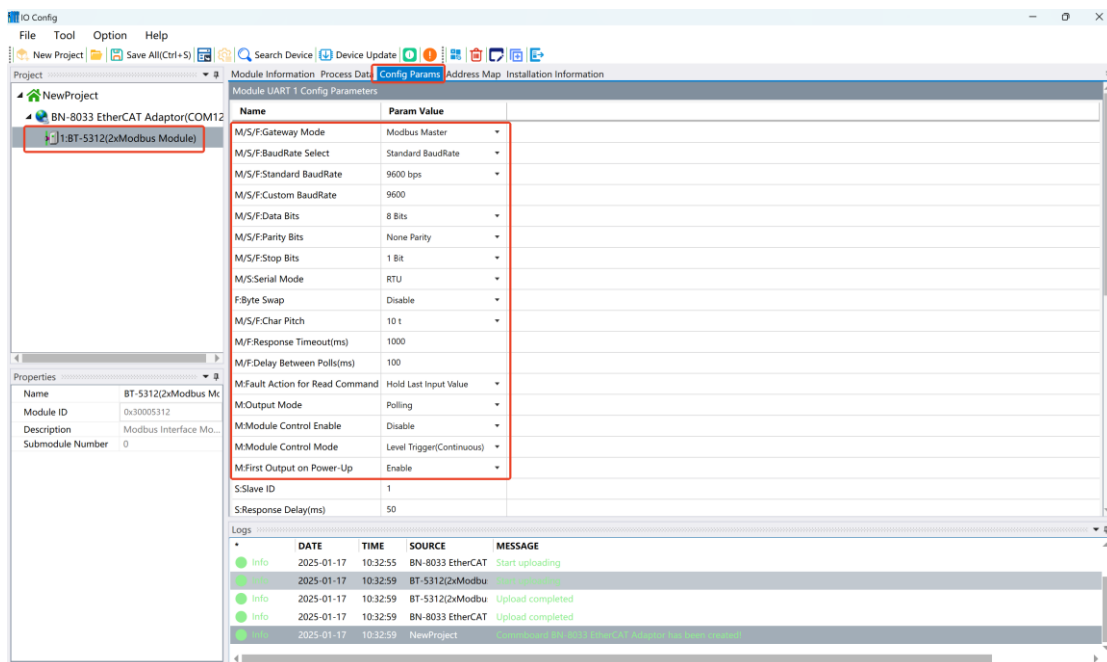

Right-click the BT-5312 module, select Submodule Management, and select the read

and write commands of the master mode according to your needs, and click OK.

Note: The M/S/F here represent the valid parameters of the master (M), slave (S), and free transparent transmission (F) modes, respectively.

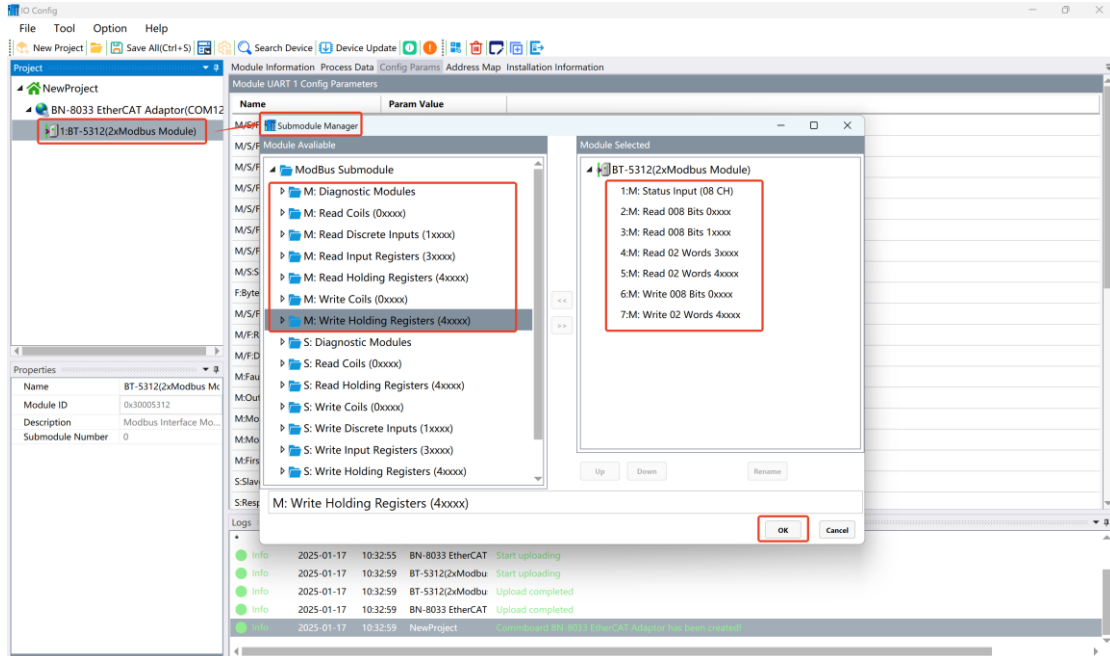

Select the command and click on the configuration parameters to modify the COM number, slave ID number and start address and other parameters.

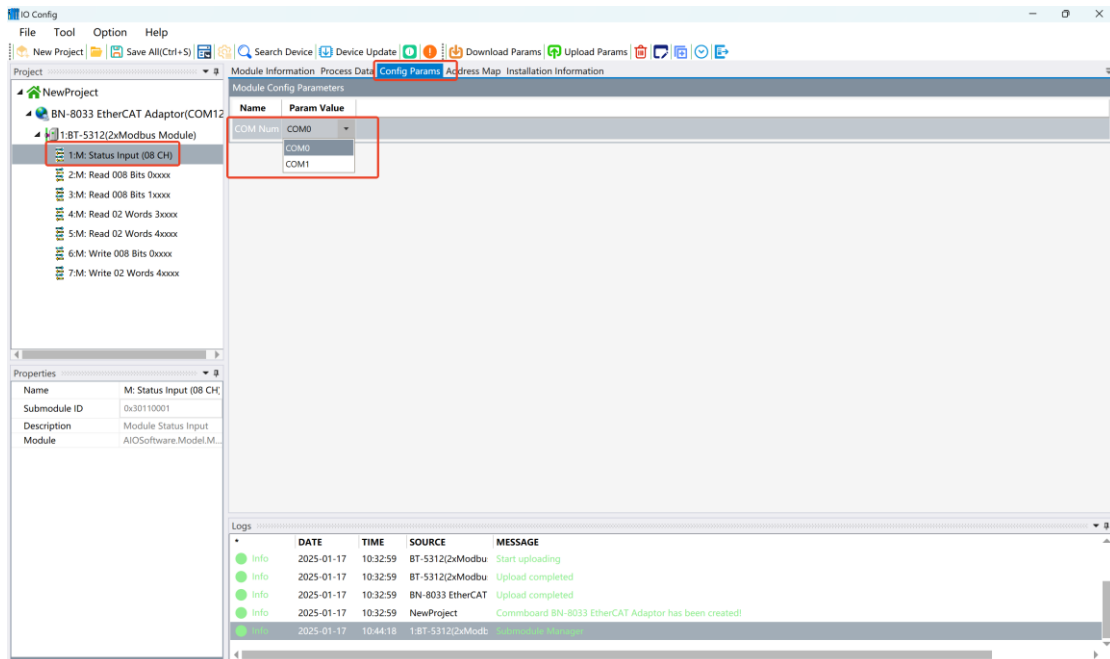

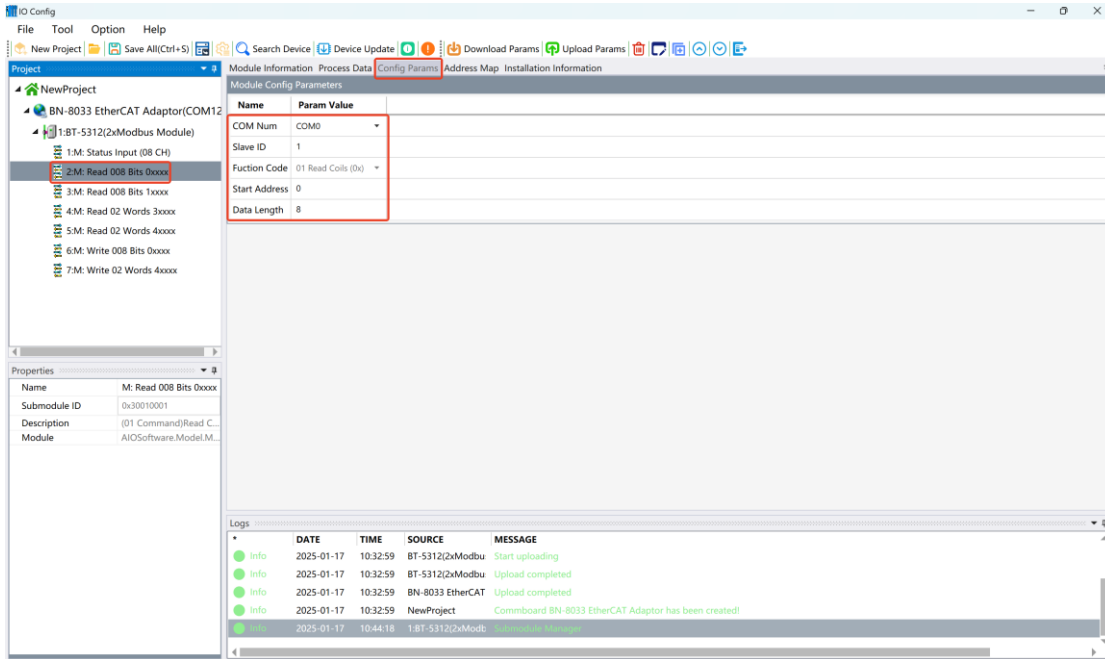

After the configuration is complete, right-click the BN-8033 and select Download Configuration, which can download the configuration parameters to the BN-8033 adapter.

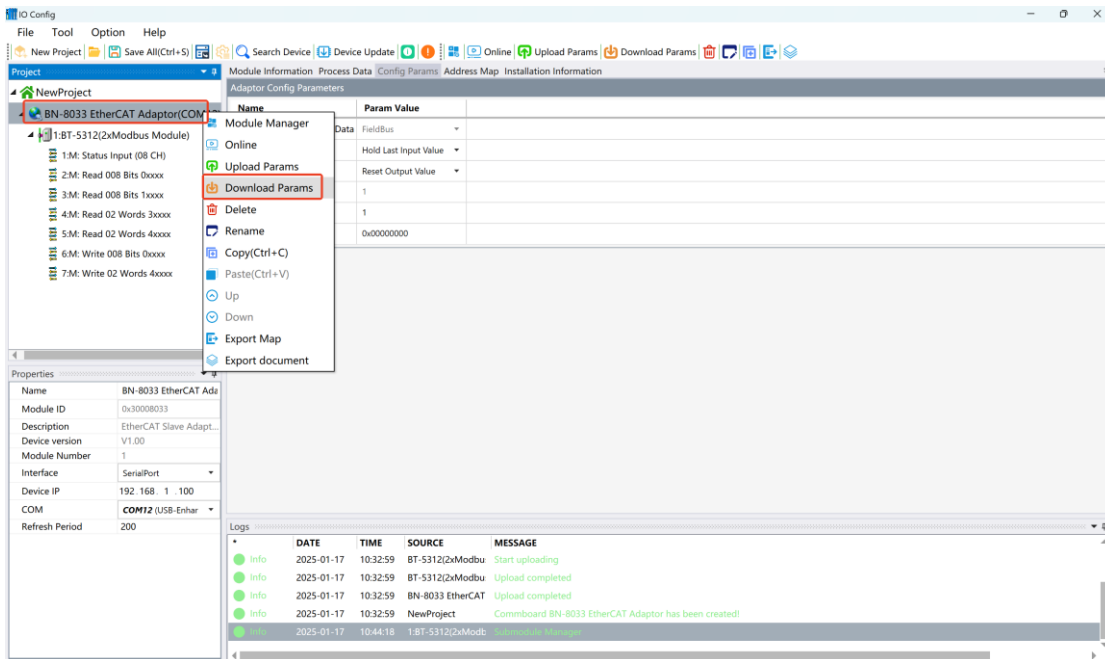

2. Use Modbus Slave to simulate the Modbus RS485 slave device connected to BT-5312.

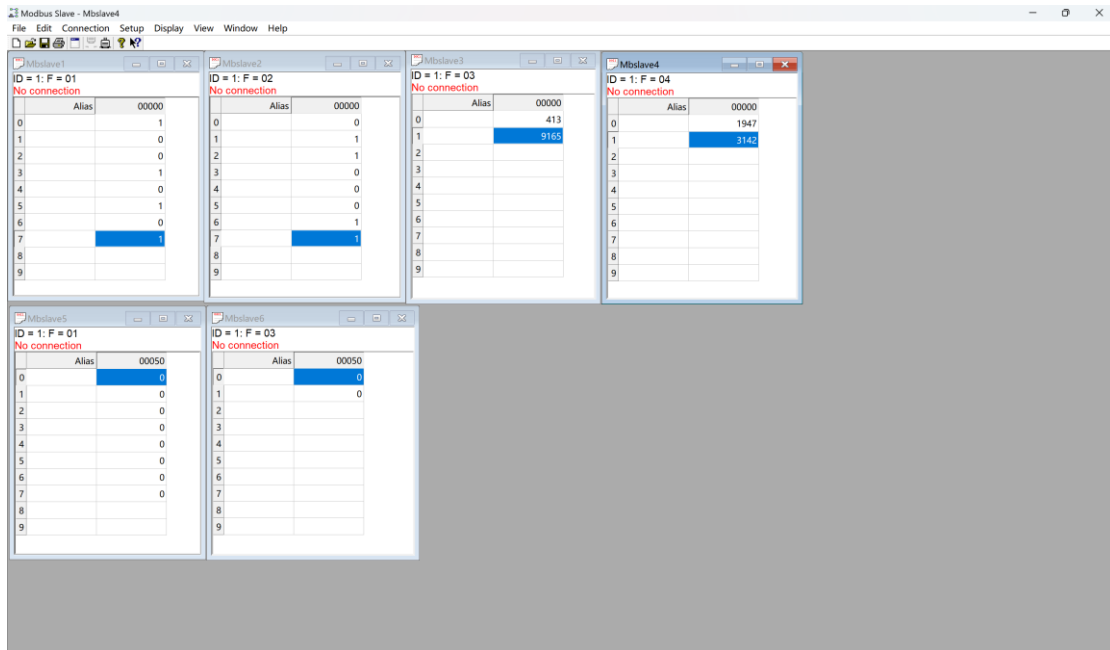

3. TwinCAT XAE Data acquisition

Open the TwinCAT XAE software, clicking it FILE->New->Project.

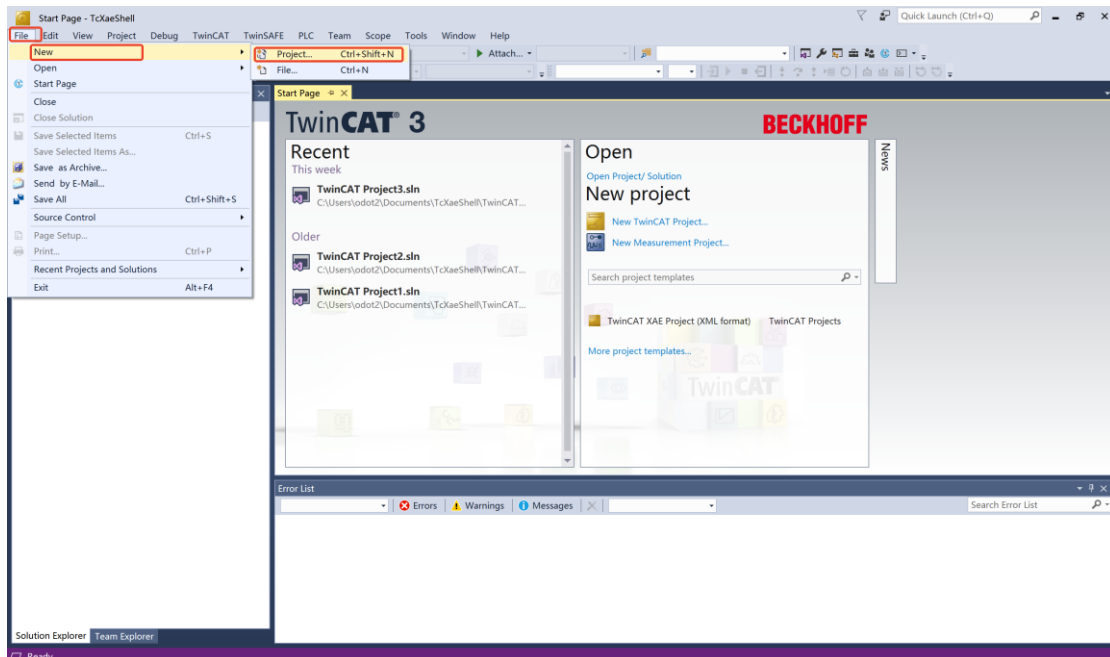

Select TwinCAT Projects as shown on the screen and select the TwinCAT XAE Project in the middle of the screen, and leave the rest as default (name, location, solution name can be modified as needed), click the OK button.

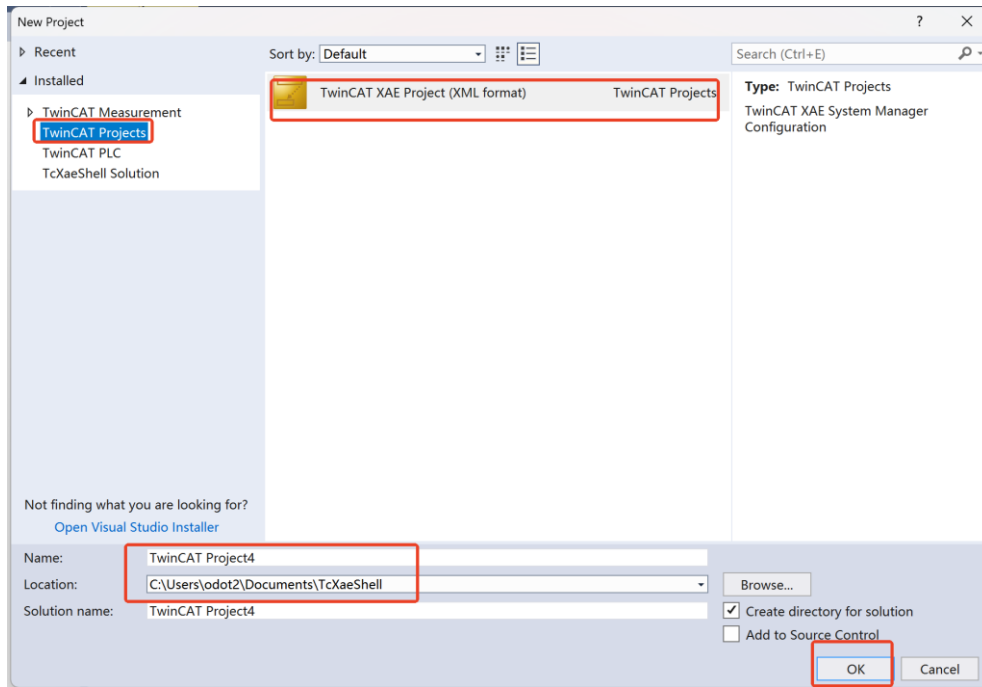

Module test

The modules are tested using the scanning function directly with the TwinCAT 3 software.

A. TwinCAT 3 software scan test (note: copy the XML file of BN-8033 to TwinCAT 3 software installation location C:\TwinCAT\3.1\Config\Io\EtherCAT.

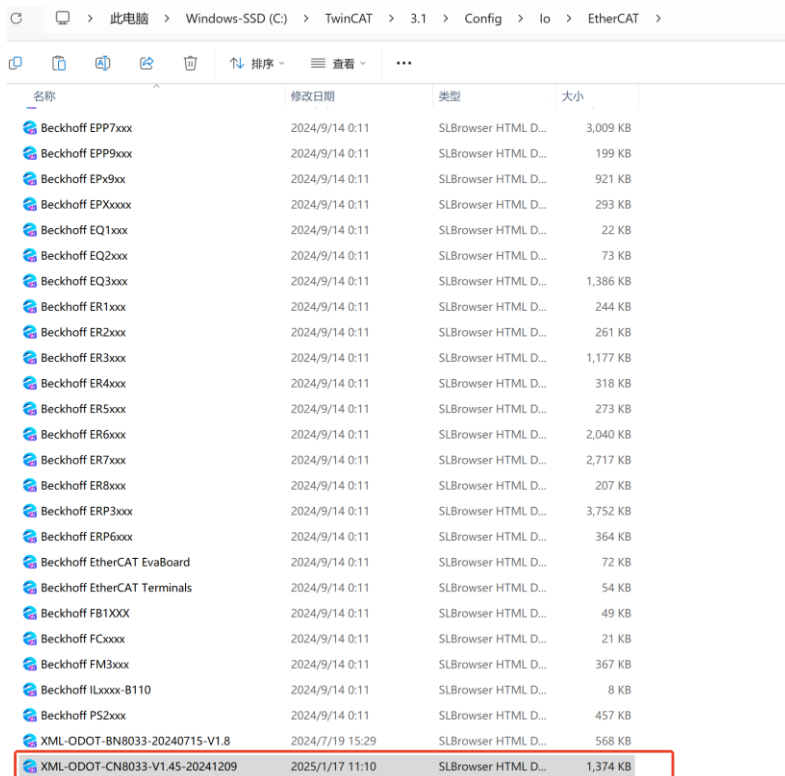

Click the I/O->Device->Scan, Click OK—OK—Yes—Yes on the pop-up windows in

turn.

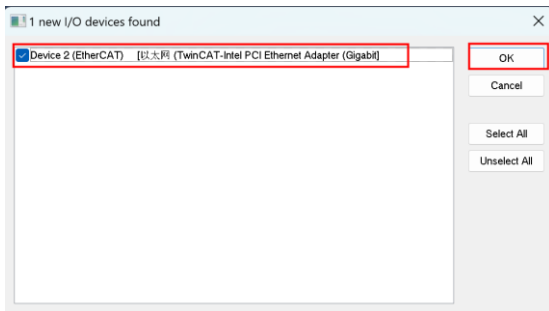
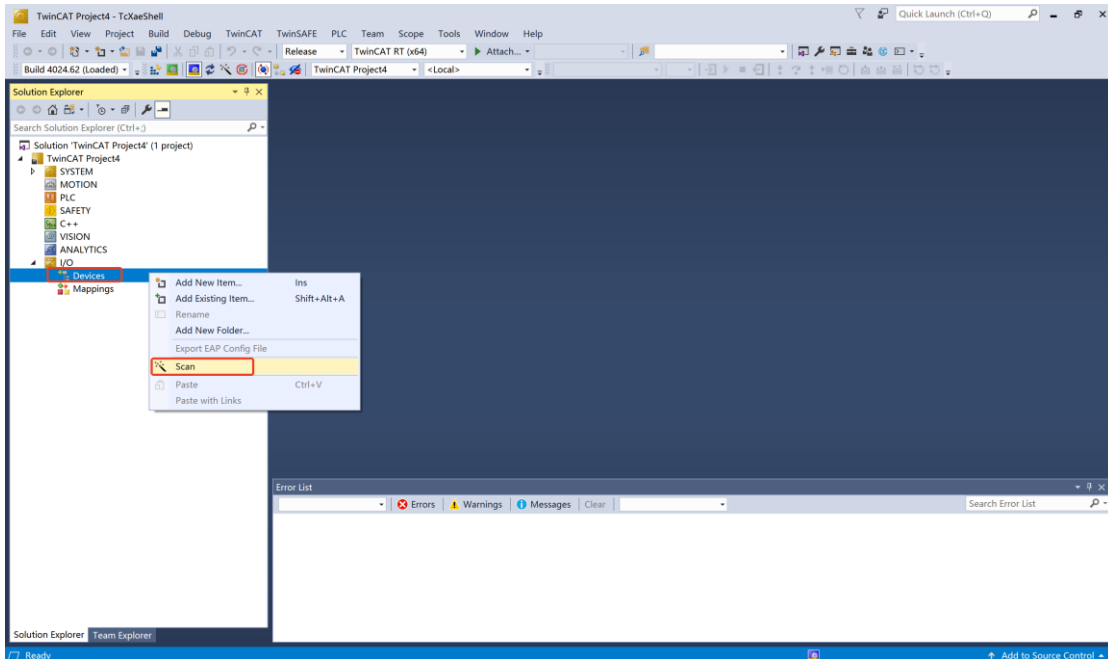

The interface to activate free run mode pops up, click the YES button in the interface to start the communication between BN-8033 and TwinCAT, and the interface on the left has been scanned for the relevant information of the module.

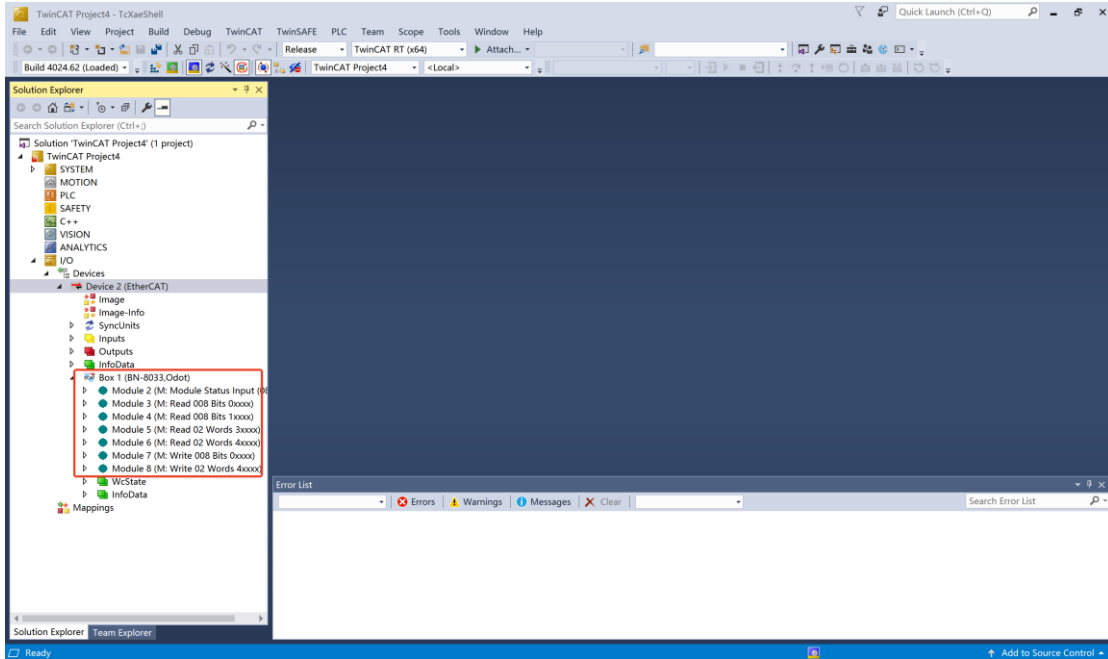

Once the scan is complete, it can see the configuration of the BN-8033 (the BT-5312 itself does not have process data, so it is not shown here). Select the read and write command to view the data collection values.

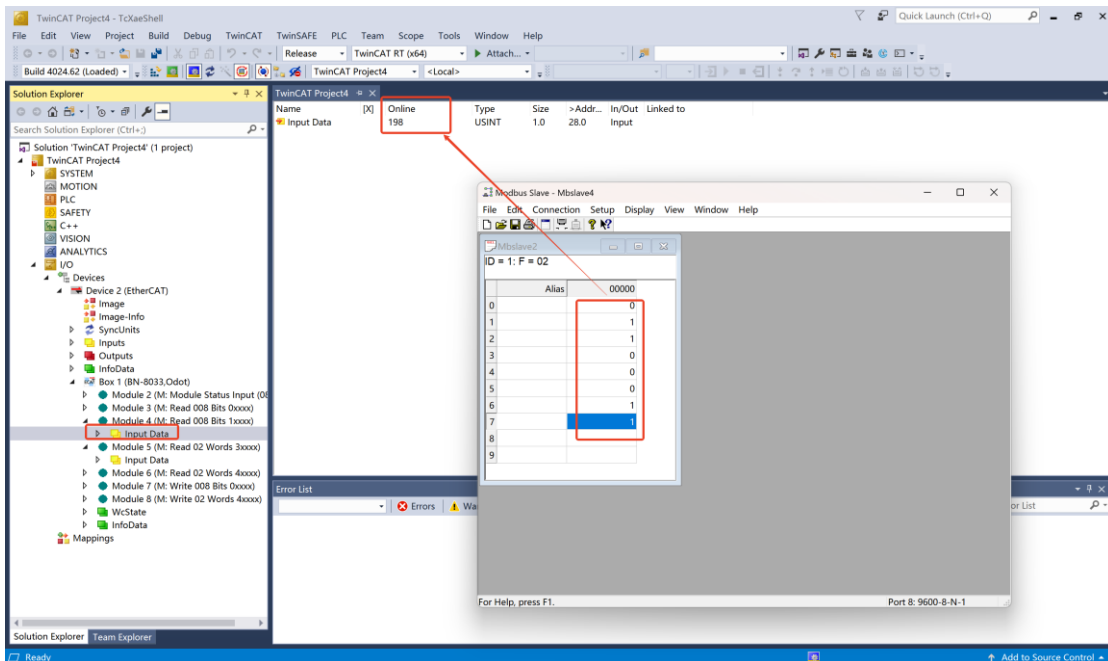

The screenshot shows the TwinCAT Project4 interface. In the 'Online' table, 'Input Data 2' is highlighted with a red box, showing values 1947 and 3142. A red arrow points from this box to a 'Modbus Slave - Mbslave2' window. This window displays a table of Modbus registers with the following data:

Alias	00000
0	
1	1947
2	3142
3	
4	
5	
6	
7	
8	
9	

The screenshot shows the TwinCAT Project4 interface. In the 'Online' table, 'Output Data 5' is highlighted with a red box, showing a value of 5. A red arrow points from this box to a 'Modbus Slave - Mbslave5' window. This window displays a table of Modbus registers with the following data:

Alias	00050
0	
1	1
2	0
3	1
4	0
5	0
6	0
7	0
8	0
9	

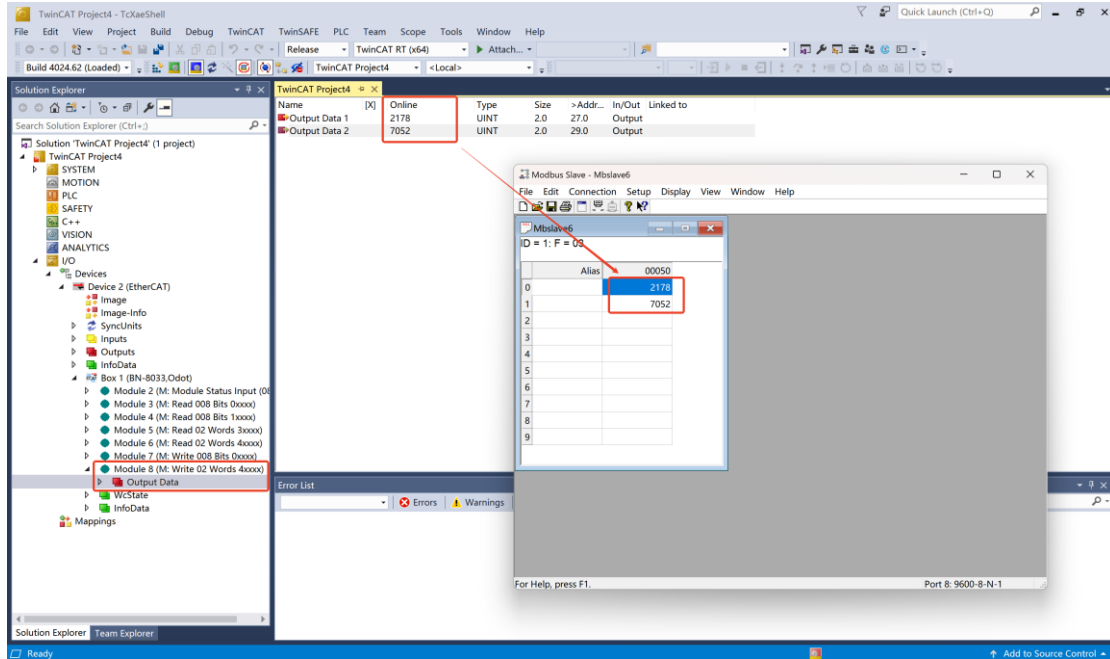

3.2 BT-5312 works in slave mode

BT-5312 Modbus RTU Slave topology map

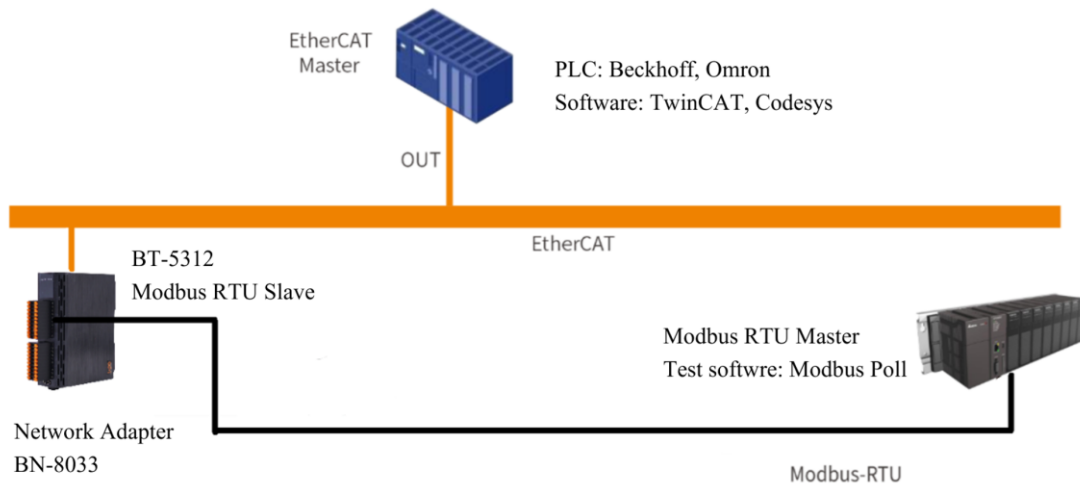

Note: 1. It needs to use IO Config to set parameters.

2. If not using the latest version of IO Config, it needs to update the device description file (hardware support package) or install the latest version of IO Config.

Hardware Composition: BN-8033 and BT-5312

Power the BN-8033 module to 24VDC system power supply and field power supply, the network cable is directly connected to the EtherCAT IN interface between the PC and the BN-8033 (**EtherCAT communication strictly distinguishes input and output, and the interface cannot be connected wrongly, otherwise the module communication may be abnormal**), BT-5312 wiring A+ B-Connect to a 485 to USB converter, and connect the USB serial port to a PC.

1. Set the parameters of BN-8033 and BT-5312

Use a Micro USB cable to connect the PC to the BN-8033 configuration interface, and the com port will be generated in the computer device manager. Open the IO Config software and click File to create a new project. After creating a new project, select "Serial Port" in the upload interface in the attribute bar, select "COM8" as the COM port, and right-click the project to upload the module to upload the BN-8033 module.

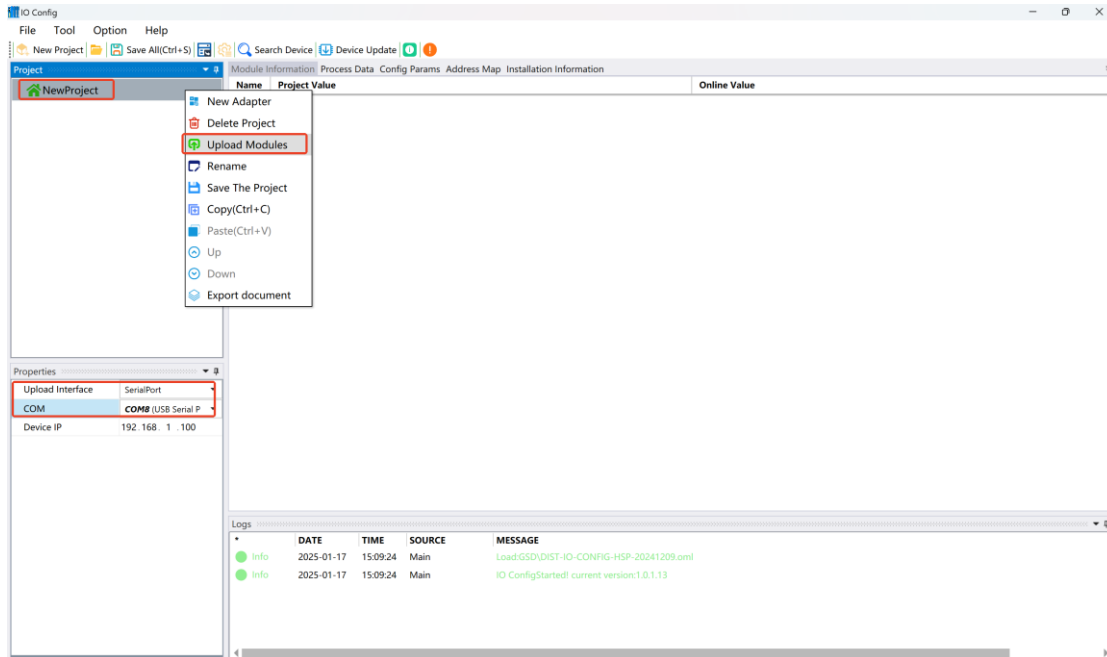

Select the BT-5312 module, click Configure Parameters, it can configure the parameters of the module, working mode: Modbus slave, 9600bps, N, 8, 1, RTU.

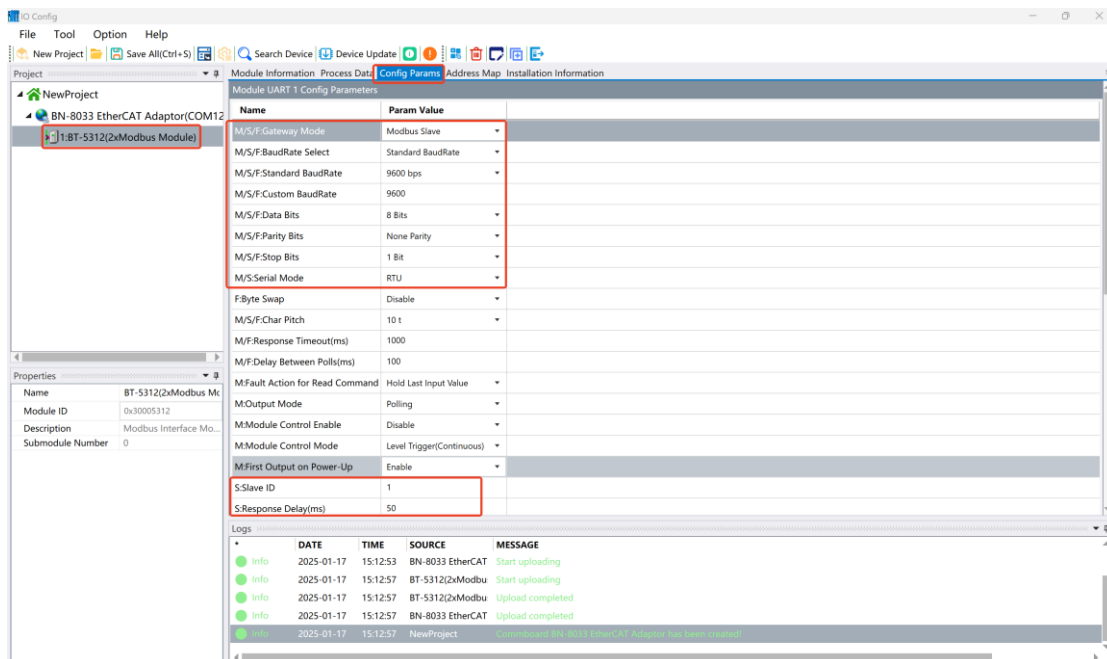

Right-click the BT-5312 module, select Submodule Management, select the read and write commands of slave mode according to your needs, and click OK. **Note: The M/S/F here represent the valid parameters of the master (M), slave (S), and free transparent transmission (F) modes, respectively.**

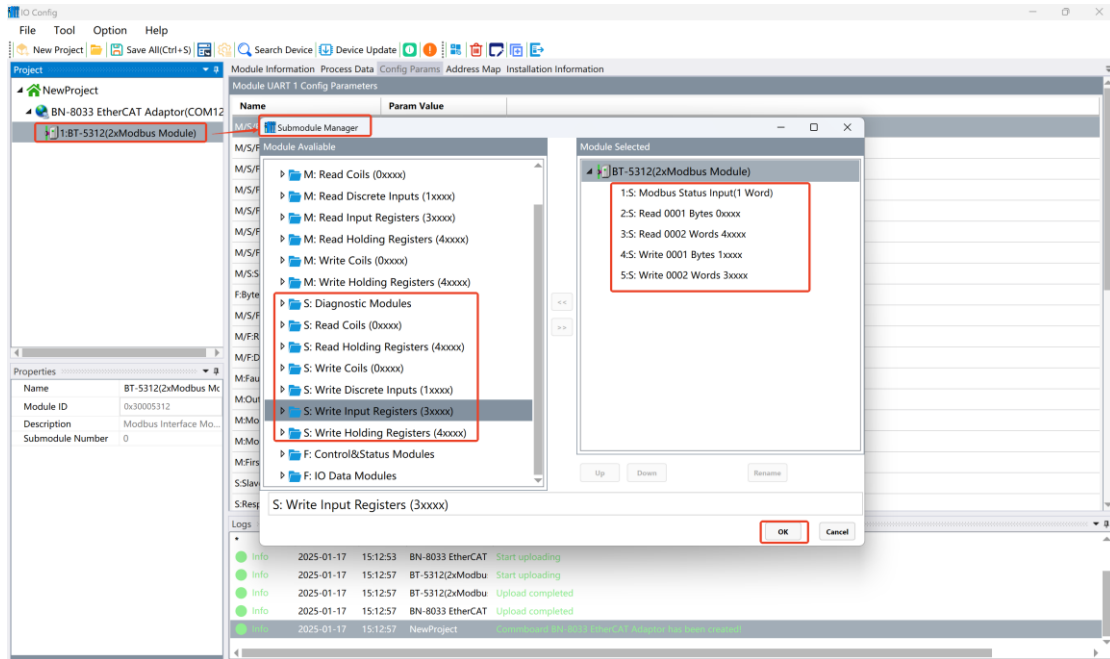

Select the command and click the configuration parameters to modify the COM number and start address.

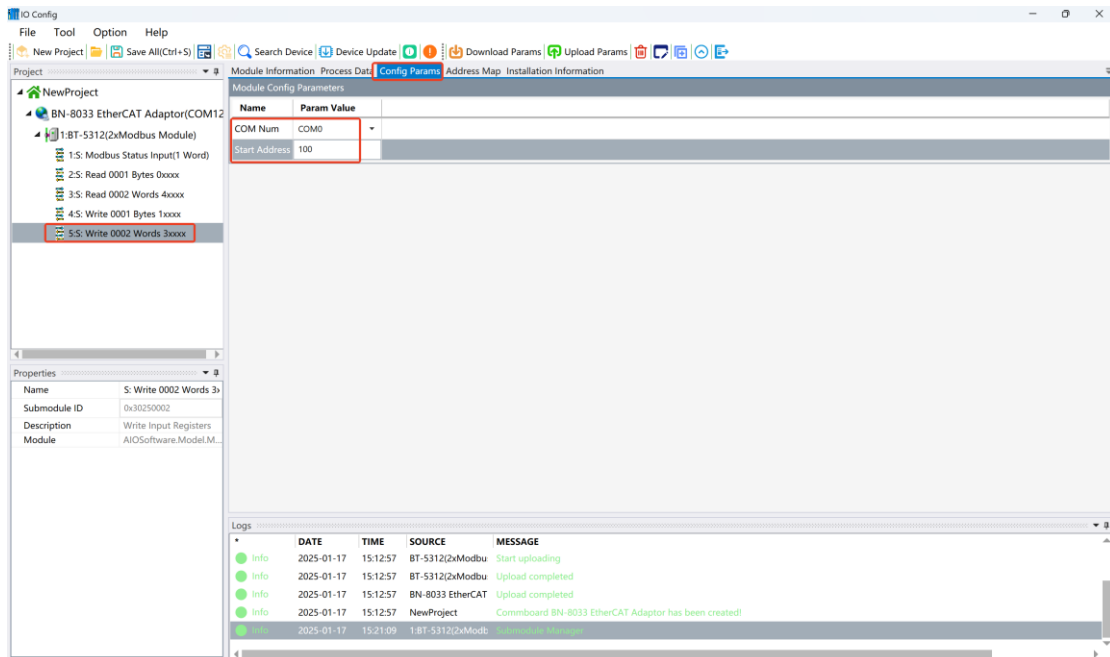

After the configuration is complete, right-click the BN-8033 and select Download Configuration, which can download the configuration parameters to the BN-8033 adapter.

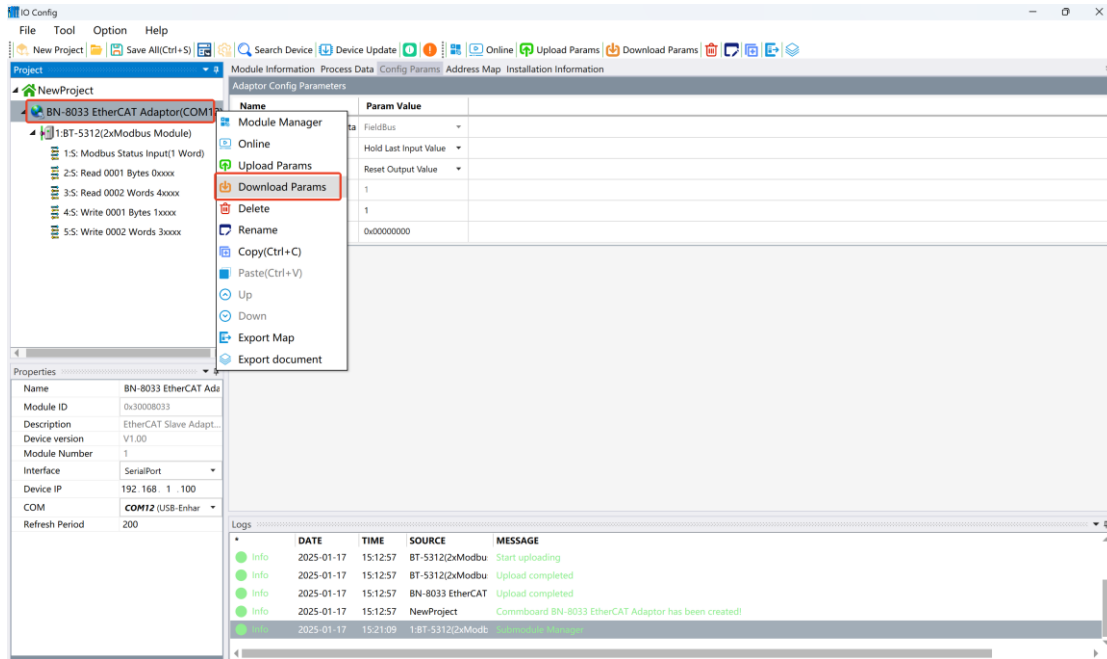

2. Use Modbus Poll software to simulate the Modbus RS485 slave equipment connected to BT-5312.

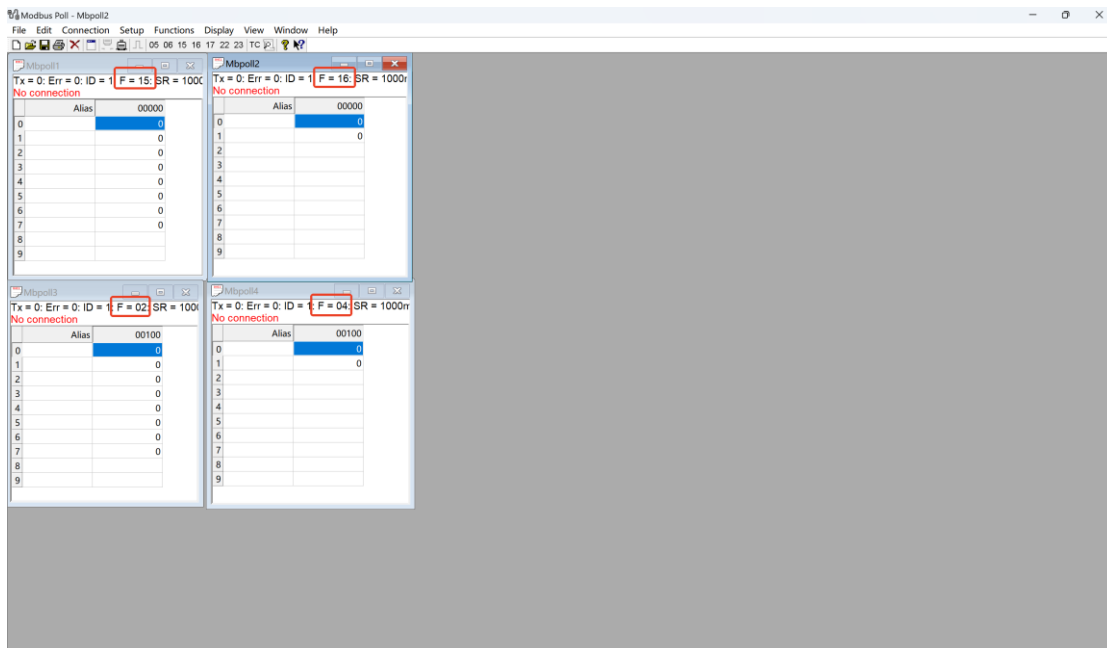

3. TwinCAT XAE Data acquisition

Open the TwinCAT XAE software, clicking it FILE->New->Project.

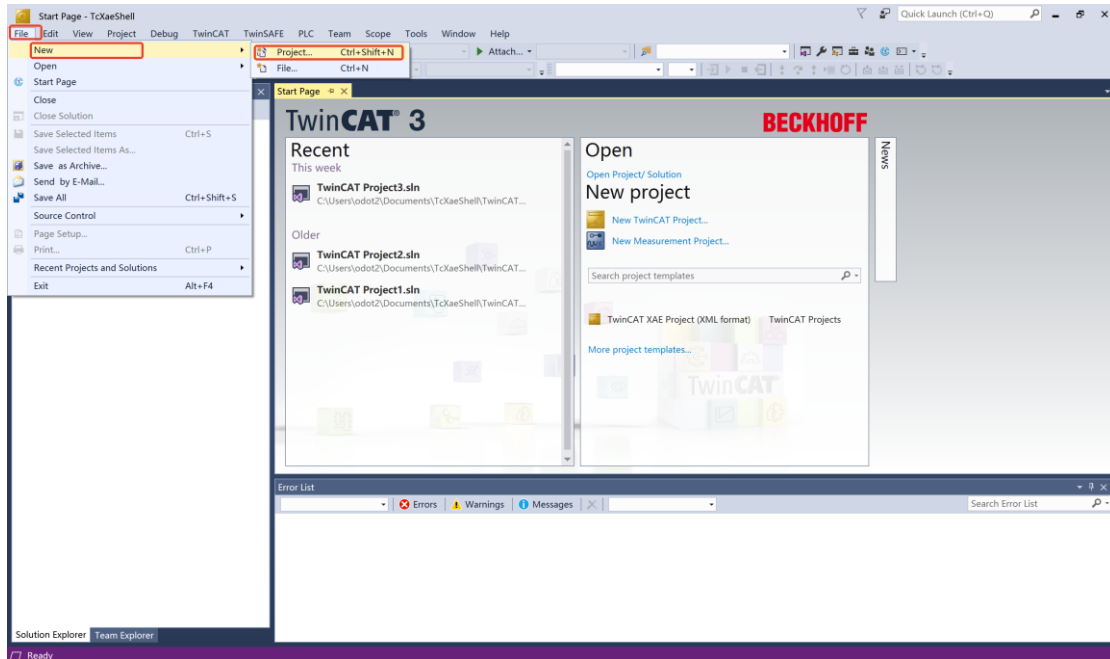

Select TwinCAT Projects as shown on the screen and select the TwinCAT XAE Project in the middle of the screen, and leave the rest as default (name, location, solution name can be modified as needed), click the OK button.

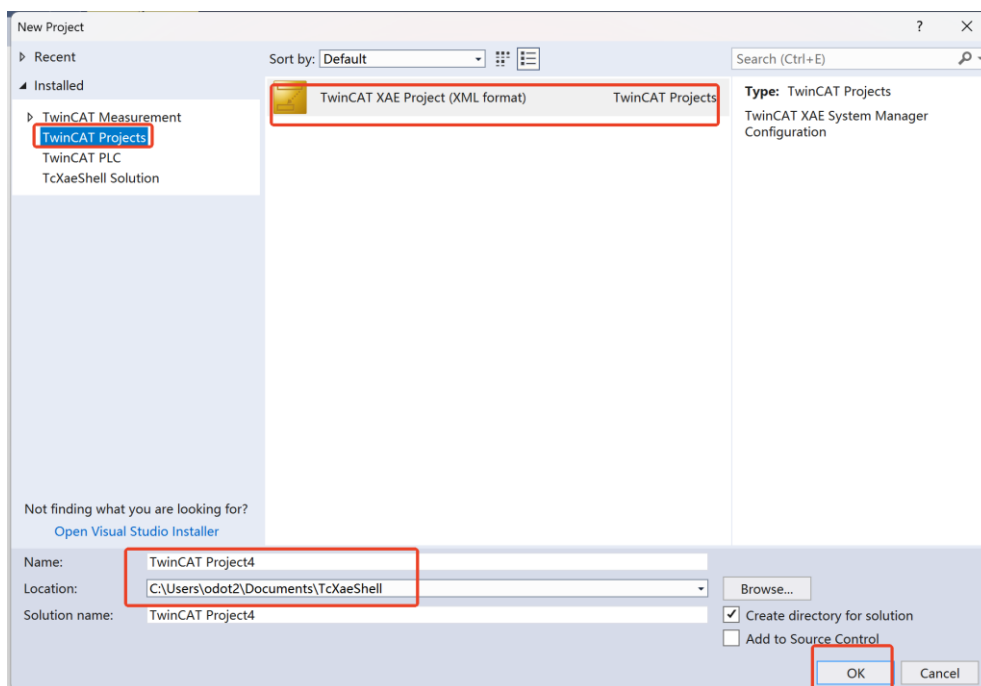

Module test

The modules are tested using the scanning function directly with the TwinCAT 3 software.

A. TwinCAT 3 software scan test (note: copy the XML file of BN-8033 to TwinCAT 3

software installation location C:\TwinCAT\3.1\Config\Io\EtherCAT.

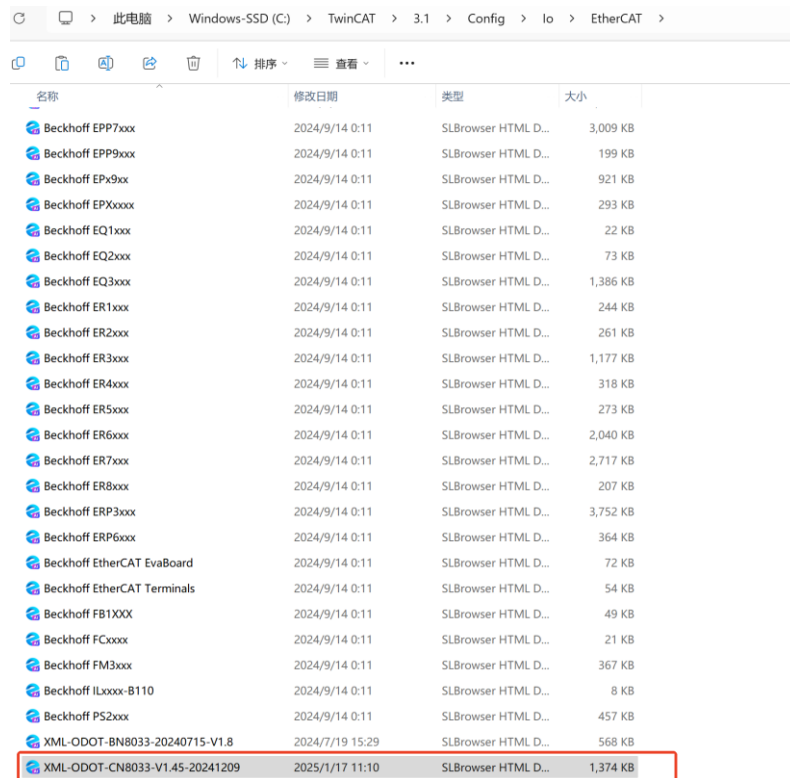

Click the I/O->Device->Scan, Click OK—OK—Yes—Yes on the pop-up windows in turn.

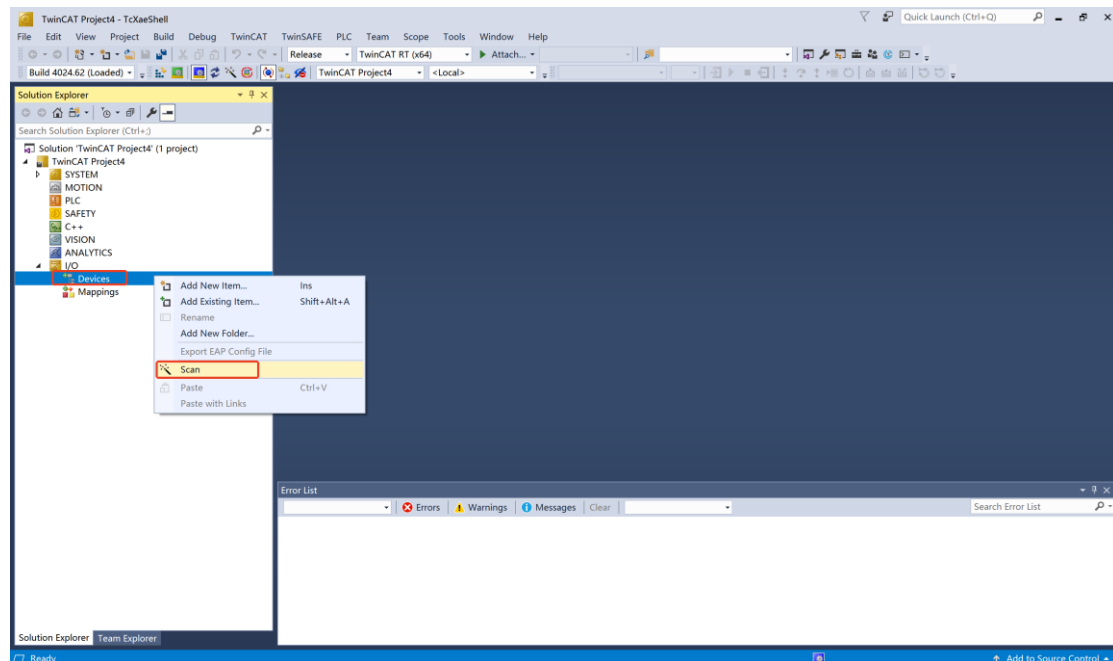

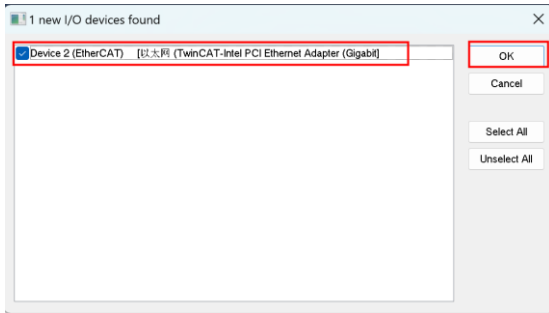

Click the Yes button in the interface to start the communication between BN-8033 and TwinCAT, and the left interface has already scanned for information about the module.

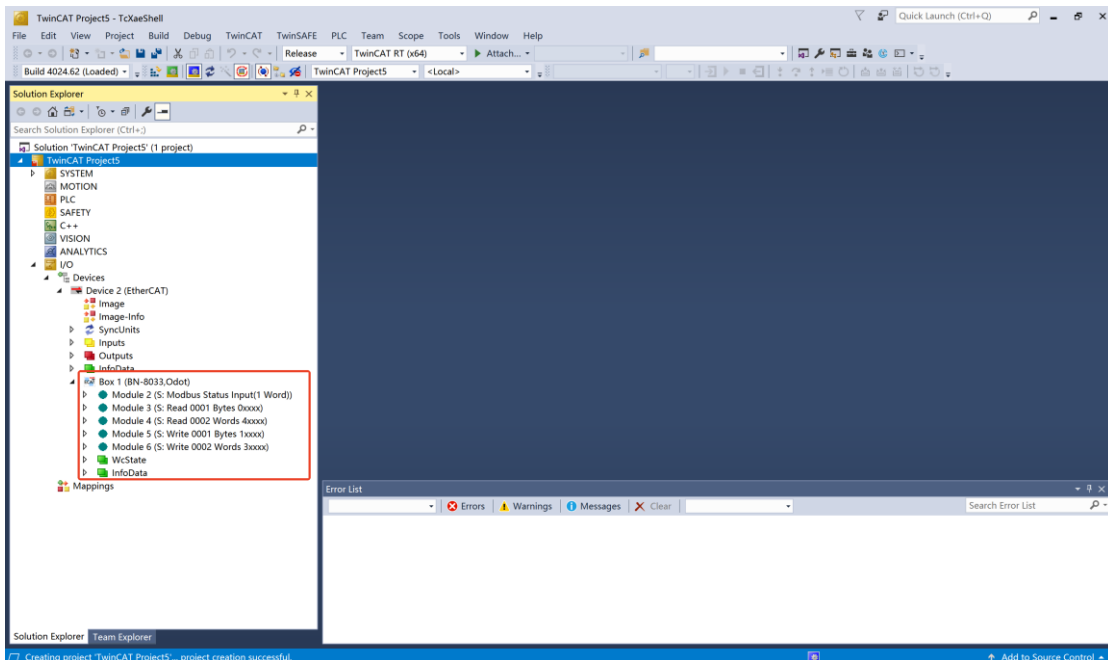

Once the scan is complete, it can see the configuration of the BN-8033 (the BT-5312 itself does not have process data, so it is not shown here). Select the read and write command to view the data collection values.

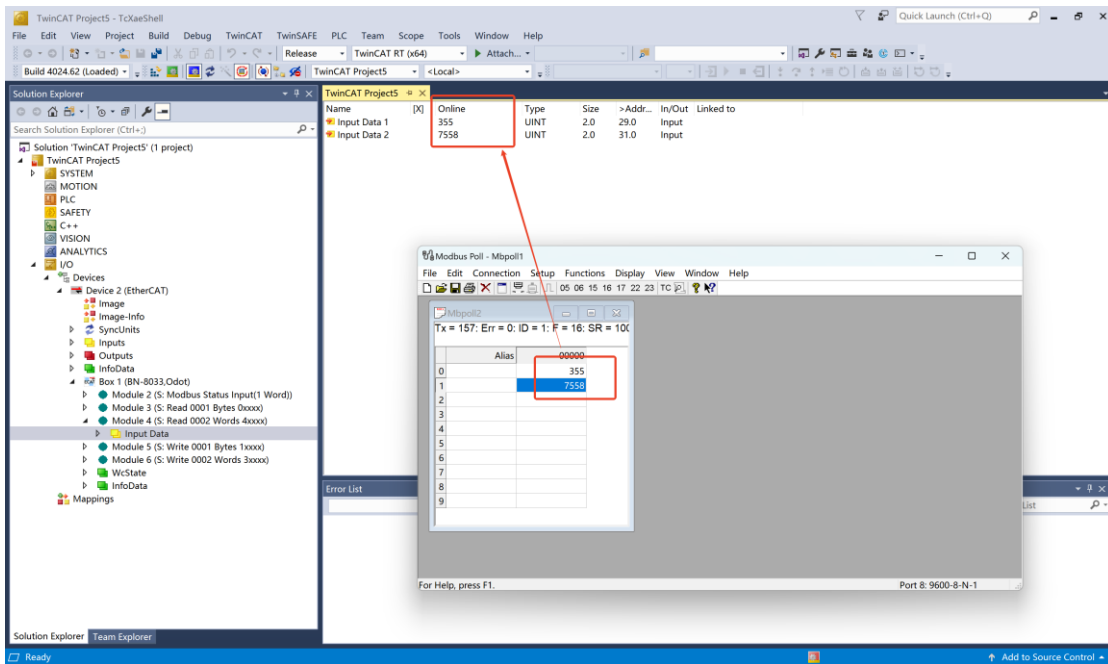
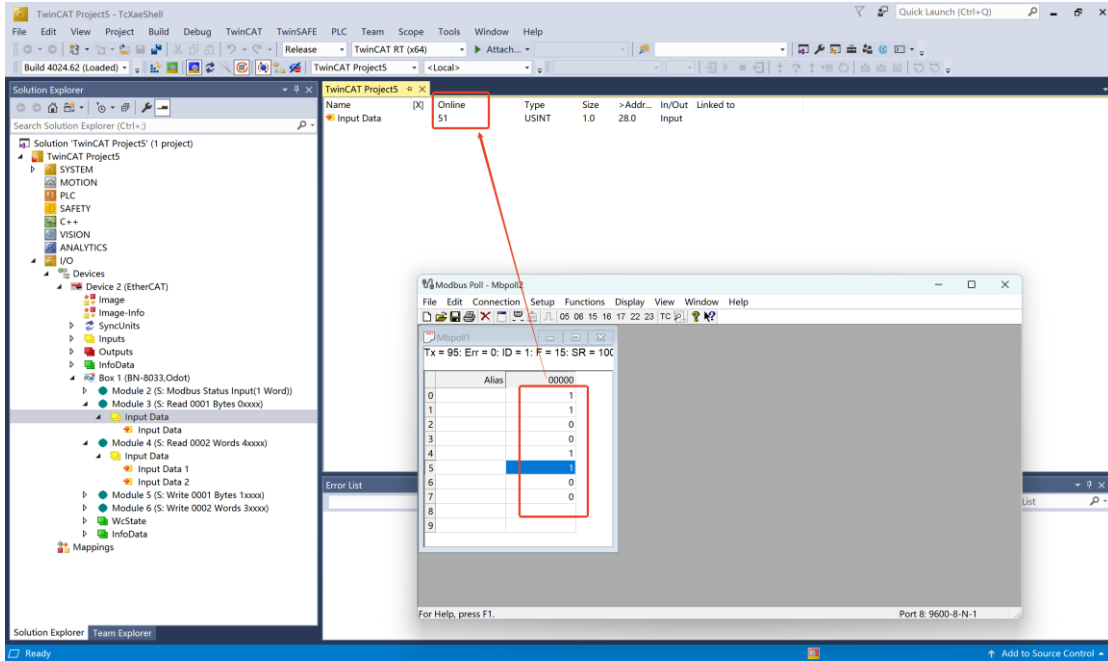

The screenshot shows the TwinCAT Project5 - TcXaeShell interface. In the 'TwinCAT Projects' window, a table lists project components:

Name	Online	Type	Size	>Addr...	In/Out	Linked to
Output Data	3	USINT	1.0	26.0	Output	

The 'Modbus Poll - Mbpoll3' window displays the following data:

Tx = 218; Err = 0; ID = 1; F = 02; SR = 11

Alias	00100
0	
1	1
2	0
3	0
4	0
5	0
6	0
7	0
8	0
9	

The screenshot shows the TwinCAT Project5 - TcXaeShell interface. In the 'TwinCAT Projects' window, a table lists project components:

Name	Online	Type	Size	>Addr...	In/Out	Linked to
Output Data 1	4287	UINT	2.0	27.0	Output	
Output Data 2	3626	UINT	2.0	29.0	Output	

The 'Modbus Poll - Mbpoll4' window displays the following data:

Tx = 308; Err = 0; ID = 1; F = 04; SR = 100

Alias	00100
0	
1	4287
2	
3	3626
4	
5	
6	
7	
8	
9	

3.3 BT-5312 works in free port communication mode

3.1 Report mode

Note: 1. It needs to use IO Config to set parameters.

2. If not using the latest version of IO Config, it needs to update the device description file (hardware support package) or install the latest version of IO Config.

Hardware Composition: BN-8033 and BT-5312

Power the BN-8033 module to 24VDC system power supply and field power supply, the network cable is directly connected to the EtherCAT IN interface between the PC and the BN-8033 (**EtherCAT communication strictly distinguishes input and output, and the interface cannot be connected wrongly, otherwise the module communication may be abnormal**), BT-5312 wiring A+ B-Connect to a 485 to USB converter, and connect the USB serial port to a PC.

1. Set the parameters of BN-8033 and BT-5312

Use a Micro USB cable to connect the PC to the BN-8033 configuration interface, and the com port will be generated in the computer device manager. Open the IO Config software and click File to create a new project. After creating a new project, select "Serial Port" in the upload interface in the attribute bar, select "COM12" as the serial port number, and right-click the project to upload the modules to upload the BN-8033 module.

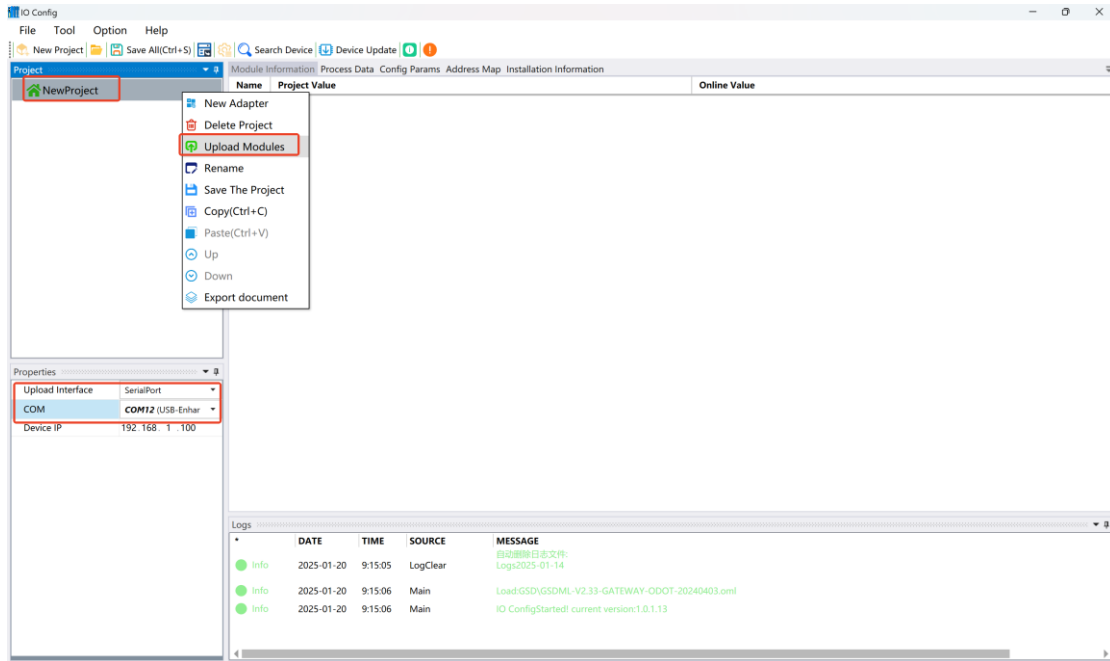

Select the BT-5312 module, click Config Params, it can configure the parameters of the module, working mode: freeport mode, 9600bps, N, 8, 1.

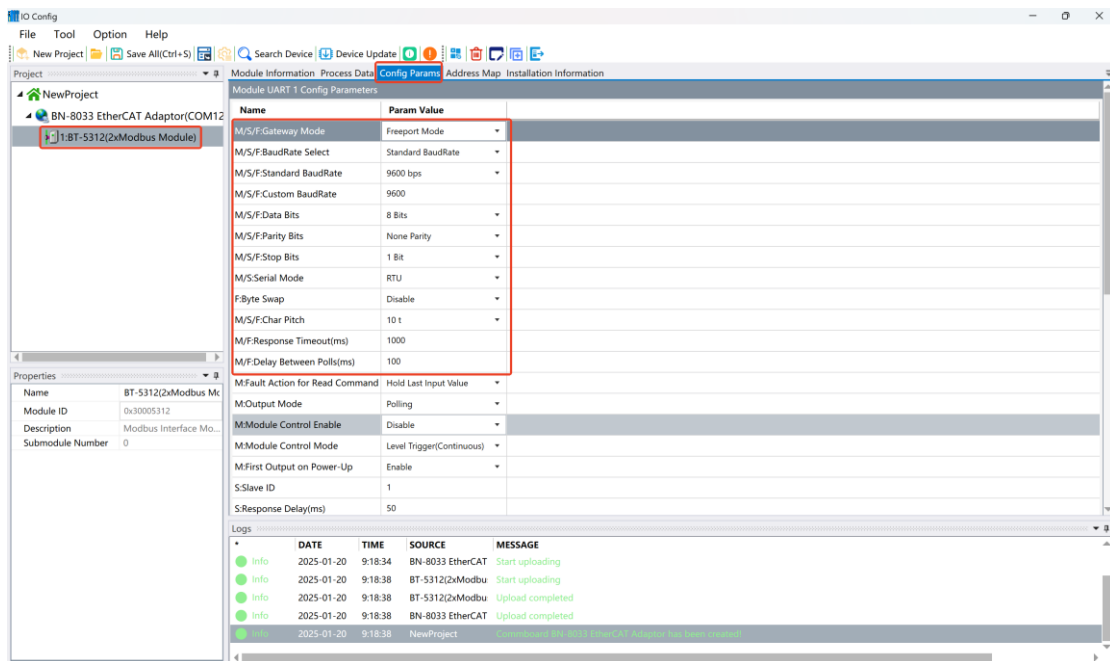

Right-click the BT-5312 module, select Submodule Management, and select the read and write commands in free transparent transmission mode according to your needs, and click OK. **Note: The M/S/F here represent the valid parameters of the master (M), slave (S), and free transparent transmission (F) modes, respectively.**

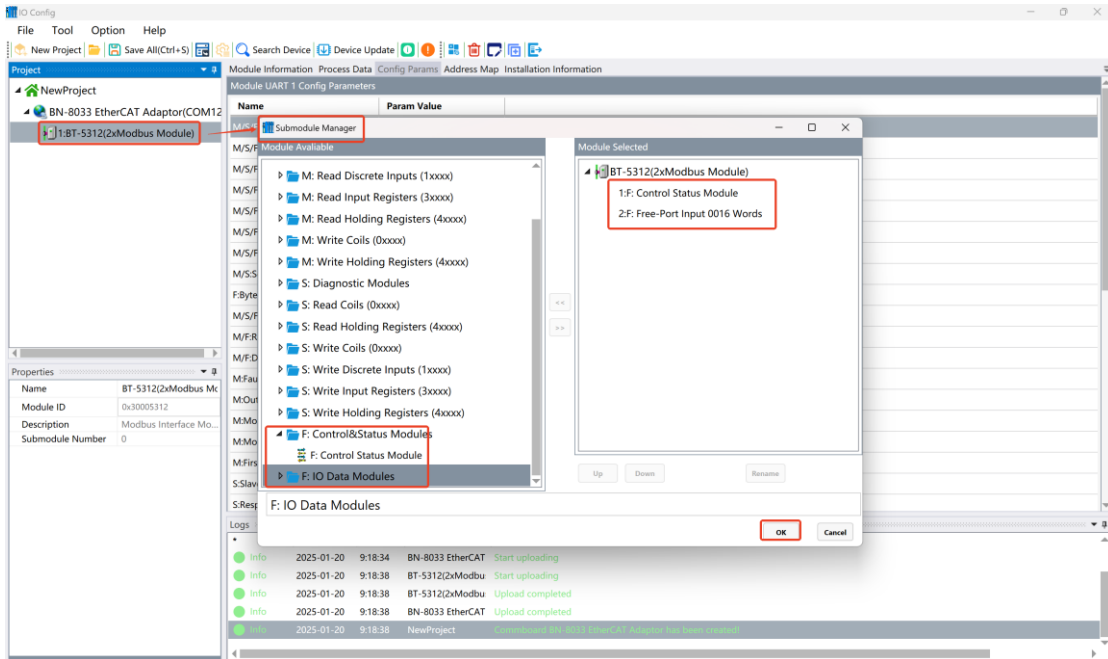

Select the command of the control status module, click the config params, and it can modify the COM number and set the communication mode to report.

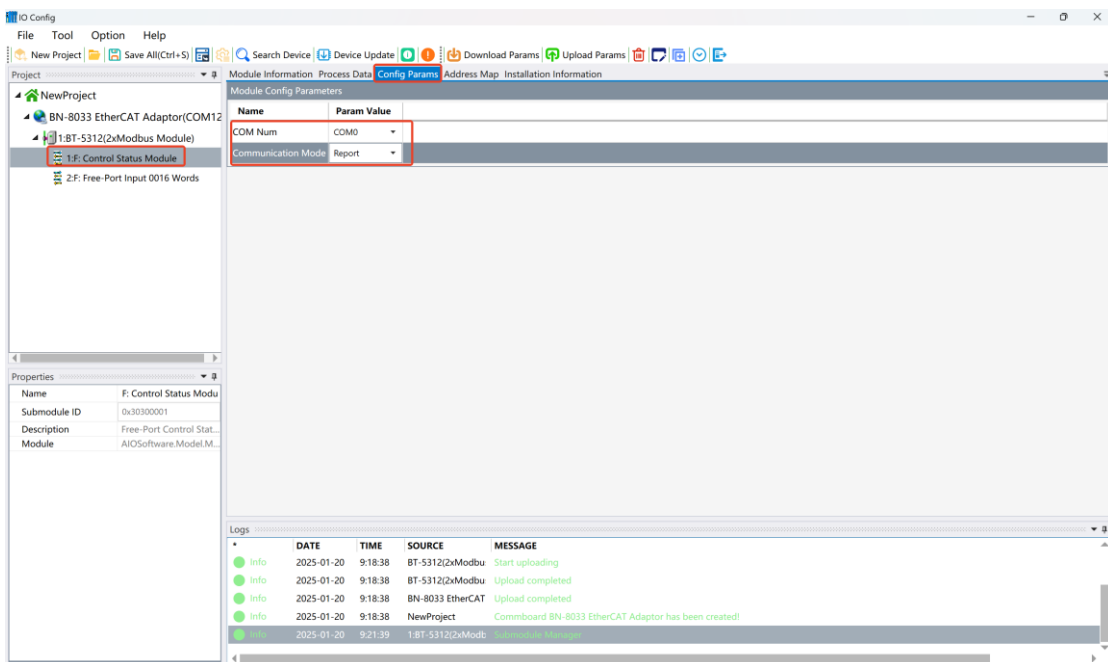

After the configuration is complete, right-click the BN-8033 and select Download Params, which can download the configuration parameters to the BN-8033 adapter.

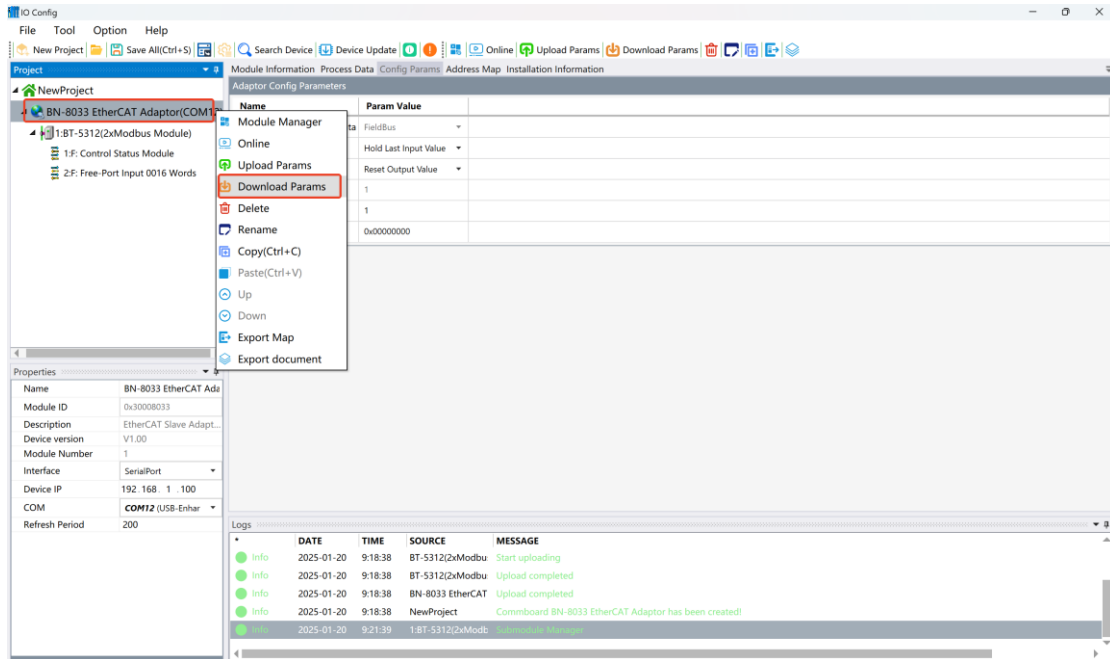

2. Use the serial port utility software to simulate the equipment connected to BT-5312.

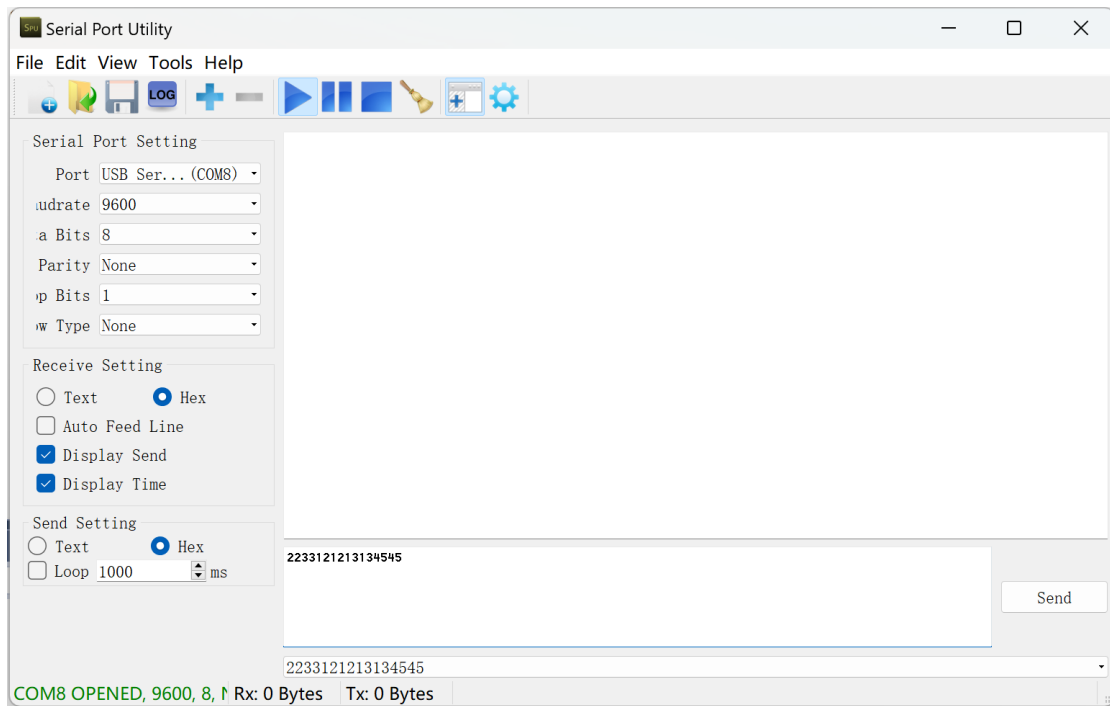

3. TwinCAT XAE Data acquisition

Open the TwinCAT XAE software, clicking it FILE->New->Project.

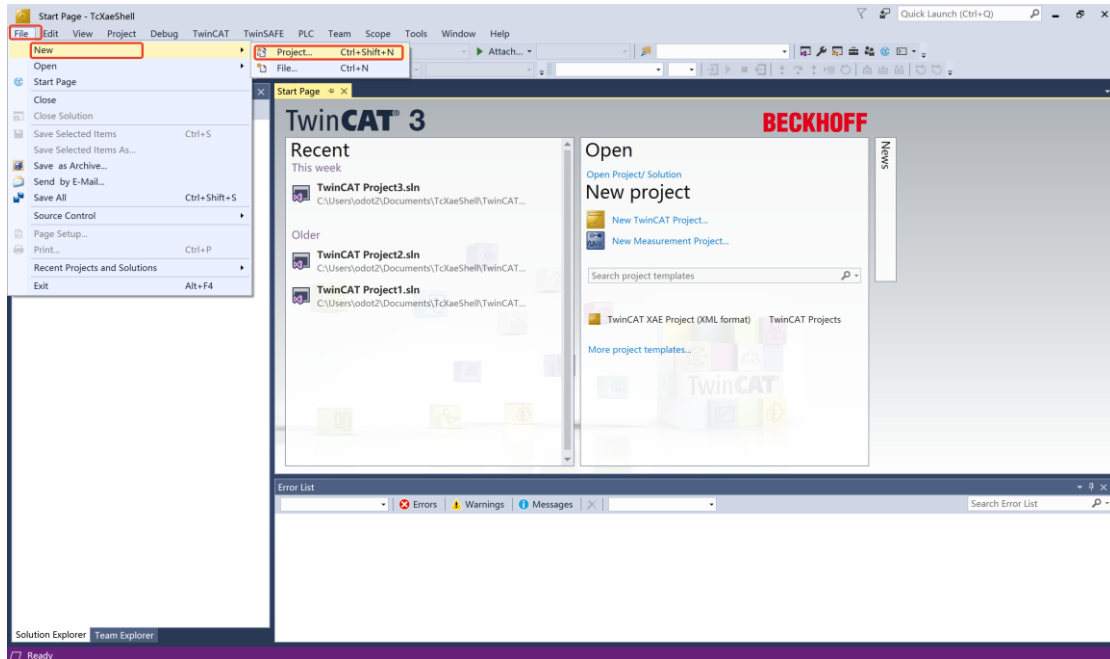

Select TwinCAT Projects as shown on the screen and select the TwinCAT XAE Project in the middle of the screen, and leave the rest as default (name, location, solution name can be modified as needed), click the OK button.

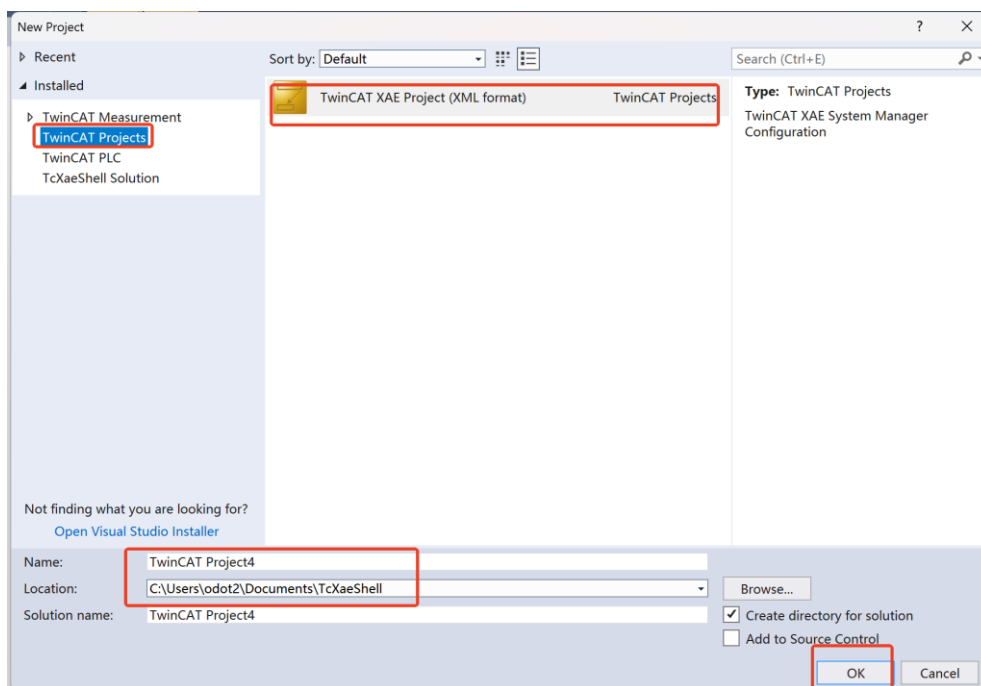

Module test

The modules are tested using the scanning function directly with the TwinCAT 3 software.

A. TwinCAT 3 software scan test (note: copy the XML file of BN-8033 to TwinCAT 3

software installation location C:\TwinCAT\3.1\Config\Io\EtherCAT.

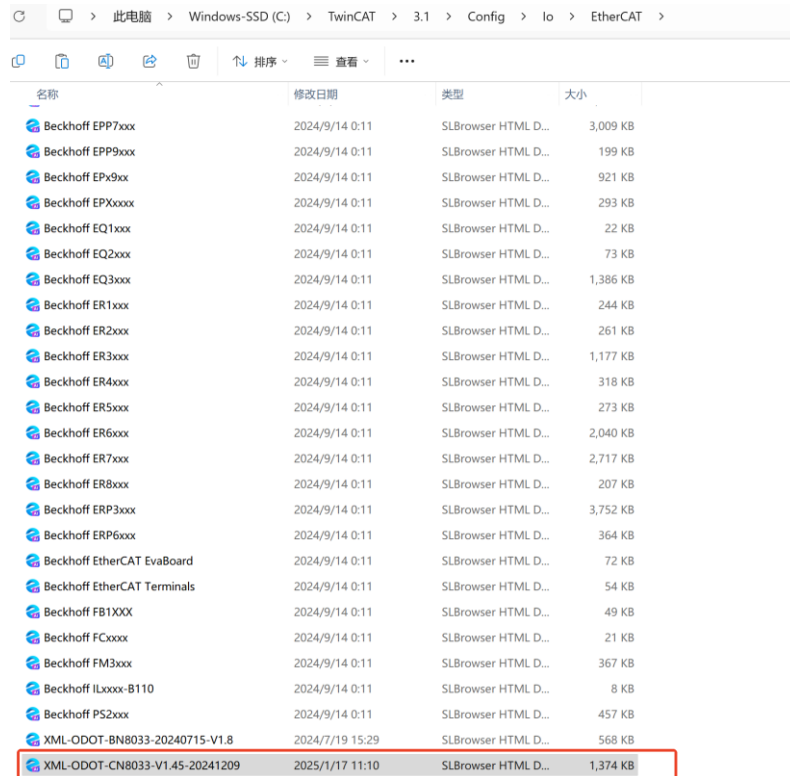

Click the I/O->Device->Scan, Click OK—OK—Yes—Yes on the pop-up windows in turn.

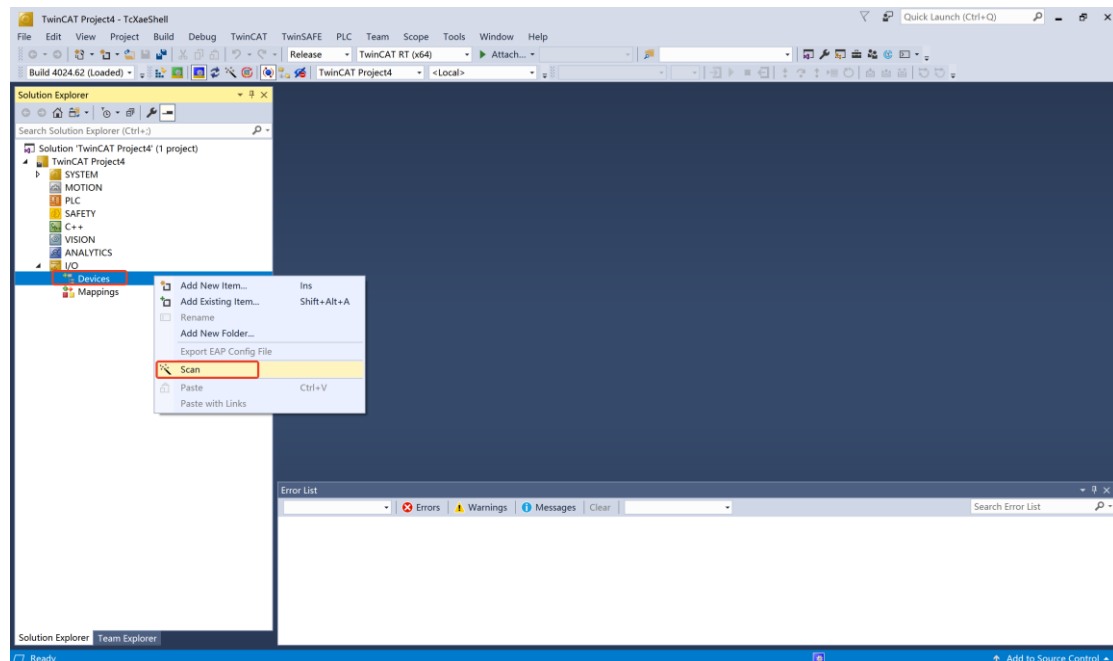

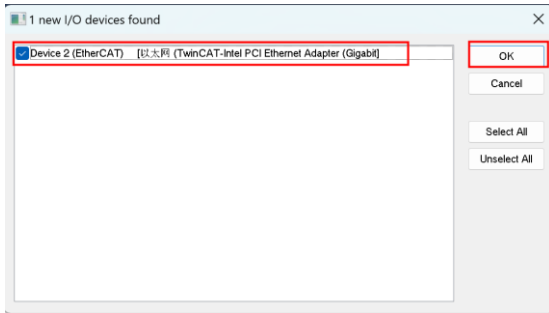

Click the Yes button in the interface to enable the communication between BN-8033 and TwinCAT, and the left interface has been scanned for information about the module.

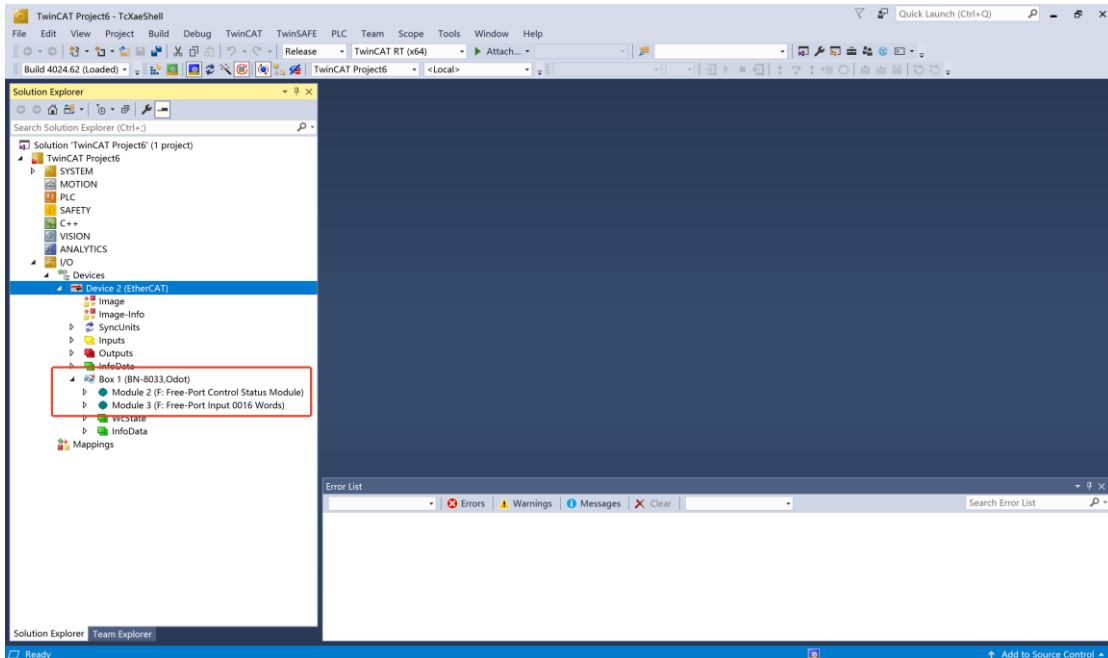

Once the scan is complete, it can see the configuration of the BN-8033 (the BT-5312 itself does not have process data, so it is not shown here). Select the read and write command to view the data collection values.

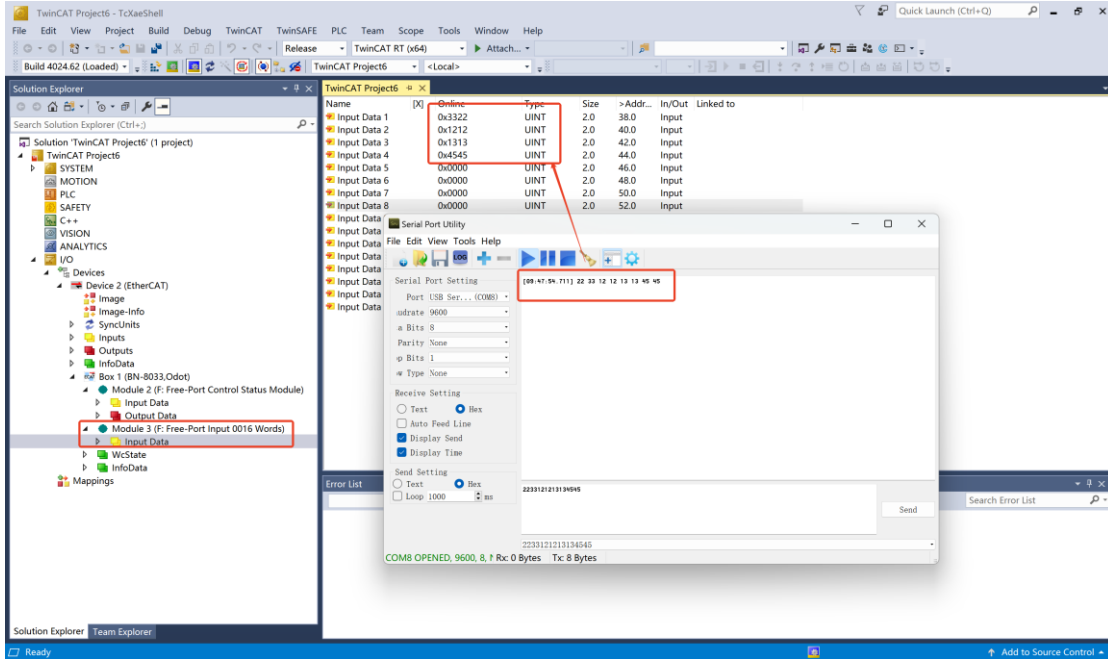

3.2 Request-Response mode

Note: 1. It needs to use IO Config to set parameters.

2. If not using the latest version of IO Config, it needs to update the device description file (hardware support package) or install the latest version of IO Config.

Hardware Composition: BN-8033 and BT-5312

Power the BN-8033 module to 24VDC system power supply and field power supply, the network cable is directly connected to the EtherCAT IN interface between the PC and the BN-8033 (**EtherCAT communication strictly distinguishes input and output, and the interface cannot be connected wrongly, otherwise the module communication may be abnormal**), BT-5312 wiring A+ B-Connect to a 485 to USB converter, and connect the USB serial port to a PC.

1. Set the parameters of BN-8033 and BT-5312

Use a Micro USB cable to connect the PC to the BN-8033 configuration interface, and the com port will be generated in the computer device manager. Open the IO Config software and click File to create a new project. After creating a new project, select "Serial Port" in the upload interface in the attribute bar, select "COM12" as the serial port number, and right-click the project to upload the modules to upload the BN-8033 module.

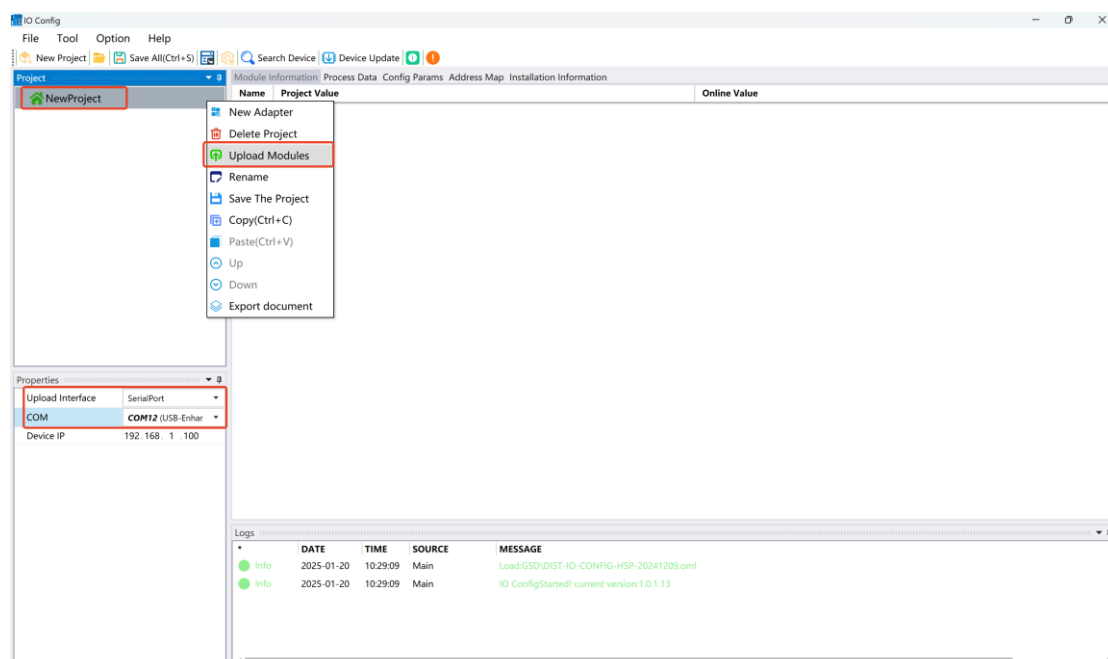

Select the BT-5312 module, click Configure Parameters, it can configure the parameters of the module, working mode: Freeport mode, 9600bps, N, 8, 1.

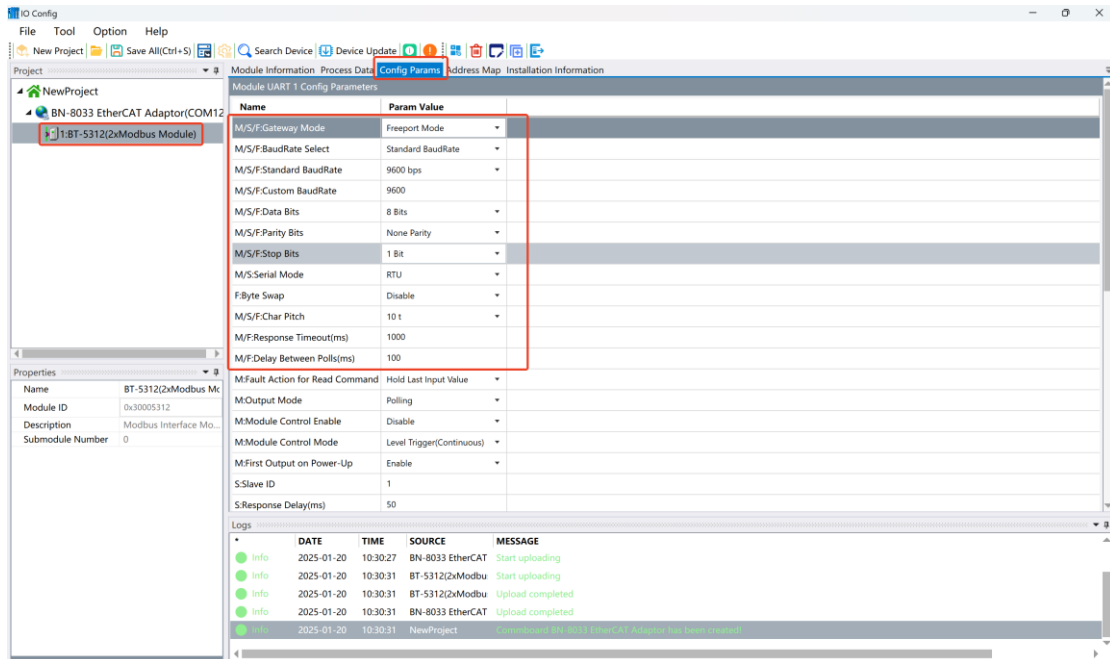

Right-click the BT-5312 module, select Submodule Management, and select the read and write commands in free transparent transmission mode according to your needs, and click OK. **Note: The M/S/F here represent the valid parameters of the master (M), slave (S), and free transparent transmission (F) modes, respectively.**

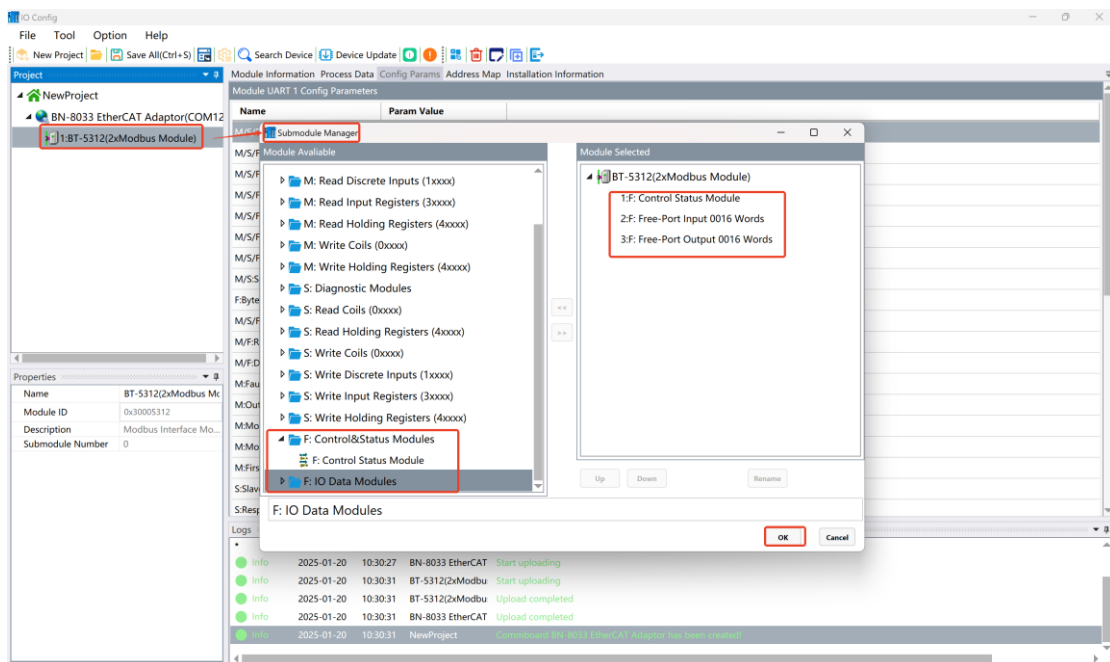

Select the command of the control status module, click the configuration parameters,

and modify the serial slogan to set the communication mode to request-response mode.

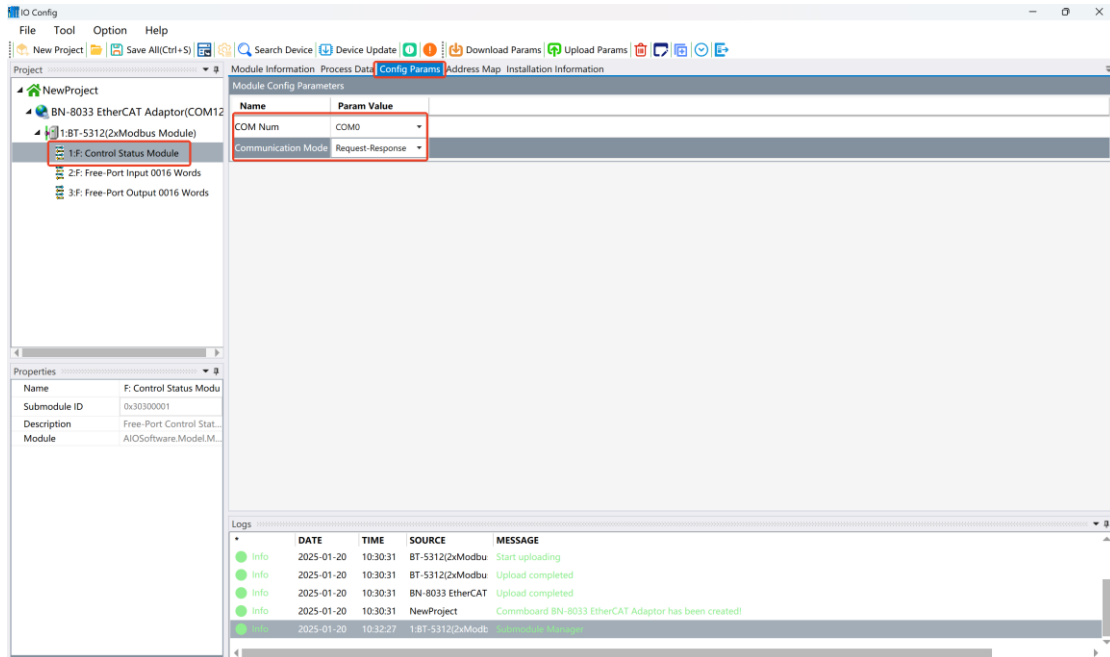

After the configuration is complete, right-click the BN-8033 and select Download Params, which can download the configuration parameters to the BN-8033 adaptor.

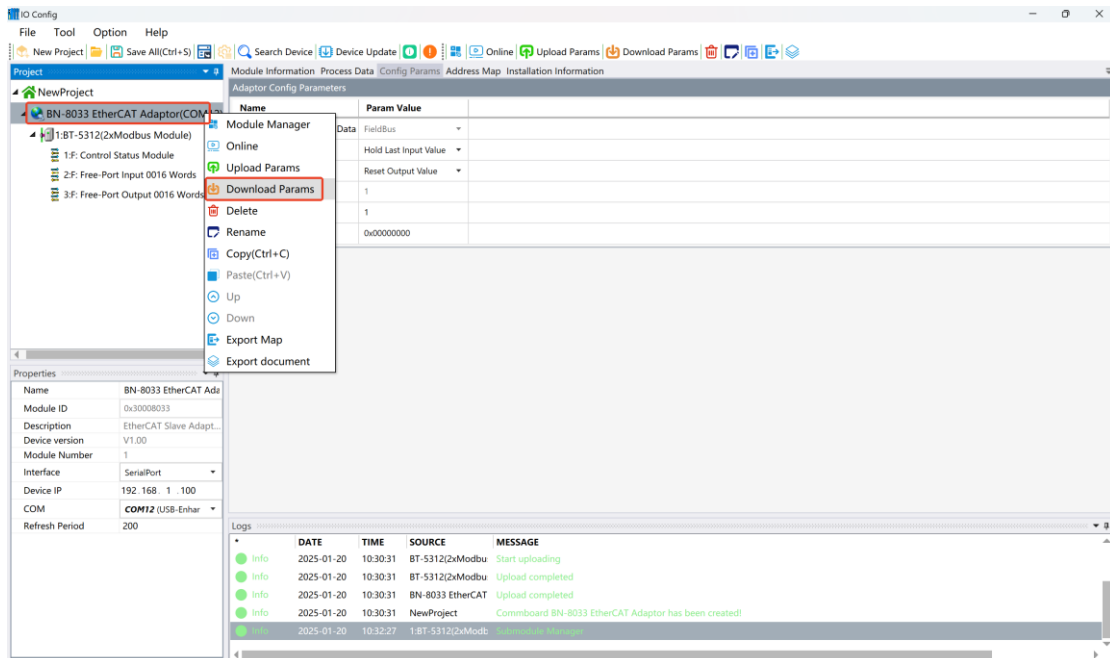

2. Use Modbus Slave software to simulate the equipment connected to BT-5312.

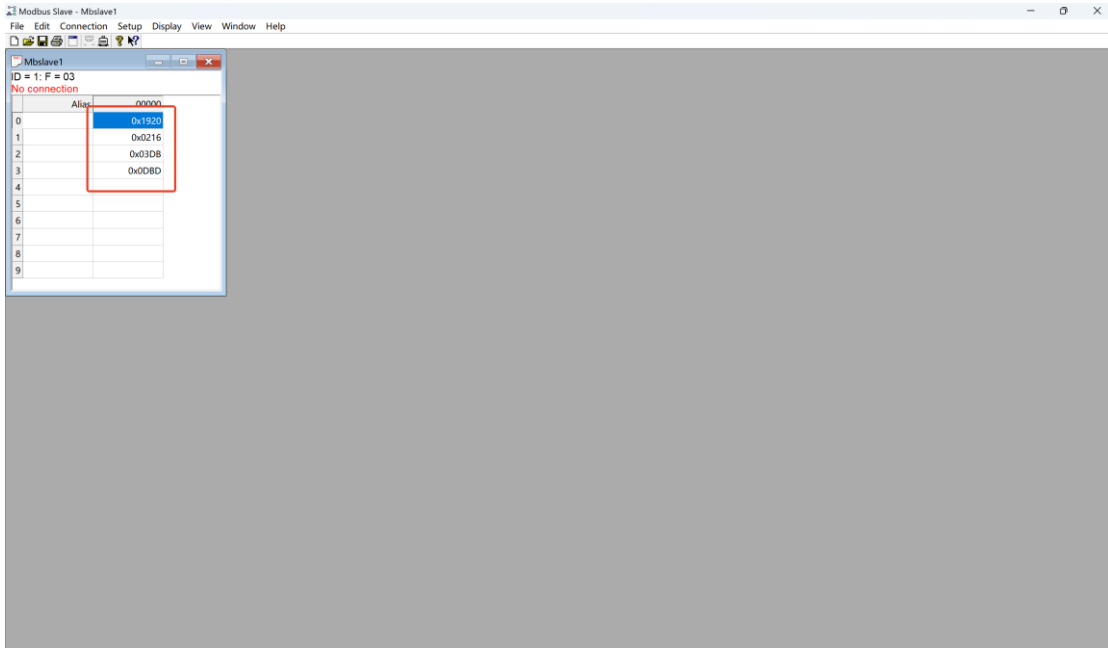

3. TwinCAT XAE Data acquisition

Open the TwinCAT XAE software, clicking it FILE->New->Project.

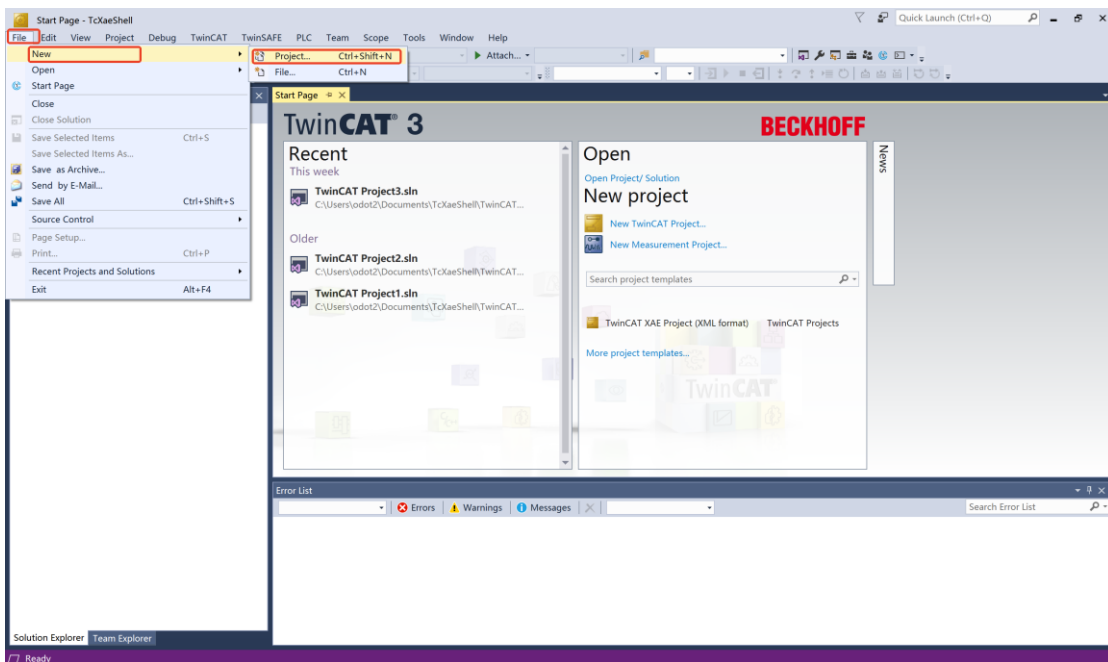

Select TwinCAT Projects as shown on the screen and select the TwinCAT XAE Project in the middle of the screen, and leave the rest as default (name, location, solution name can be modified as needed), click the OK button.

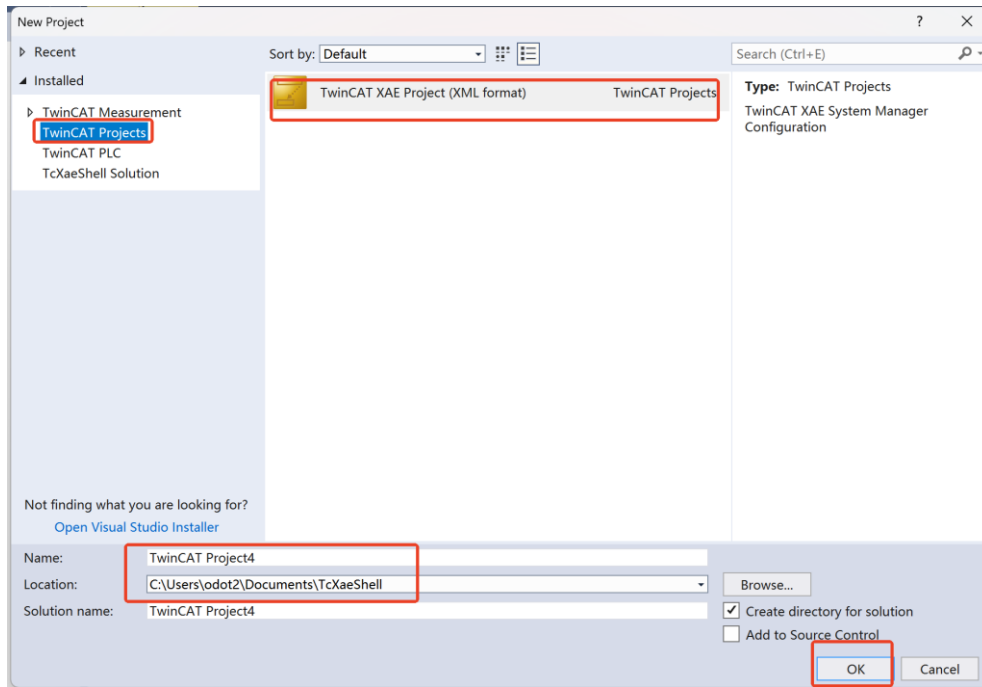

Module test

The modules are tested using the scanning function directly with the TwinCAT 3 software.

A. TwinCAT 3 software scan test (note: copy the XML file of BN-8033 to TwinCAT 3 software installation location C:\TwinCAT\3.1\Config\Io\EtherCAT.

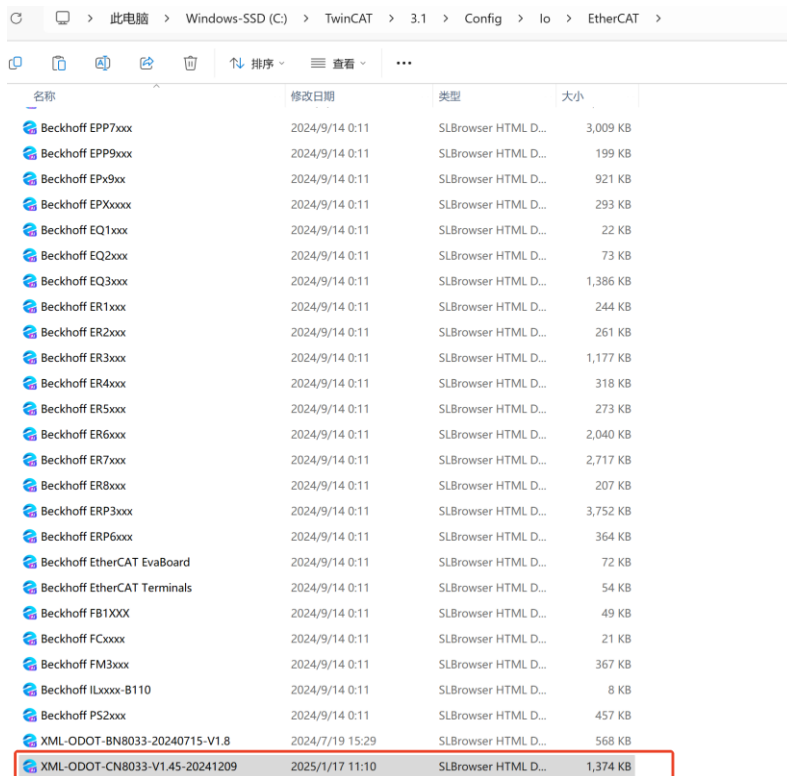

Click the I/O->Device->Scan, Click OK—OK—Yes—Yes on the pop-up windows in

turn.

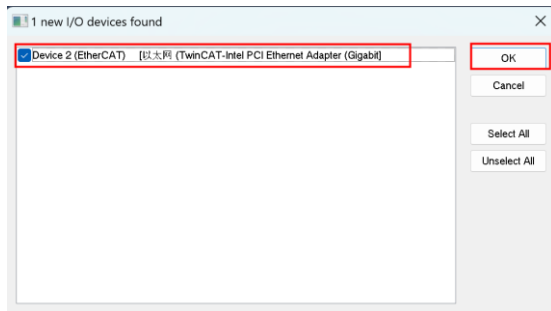
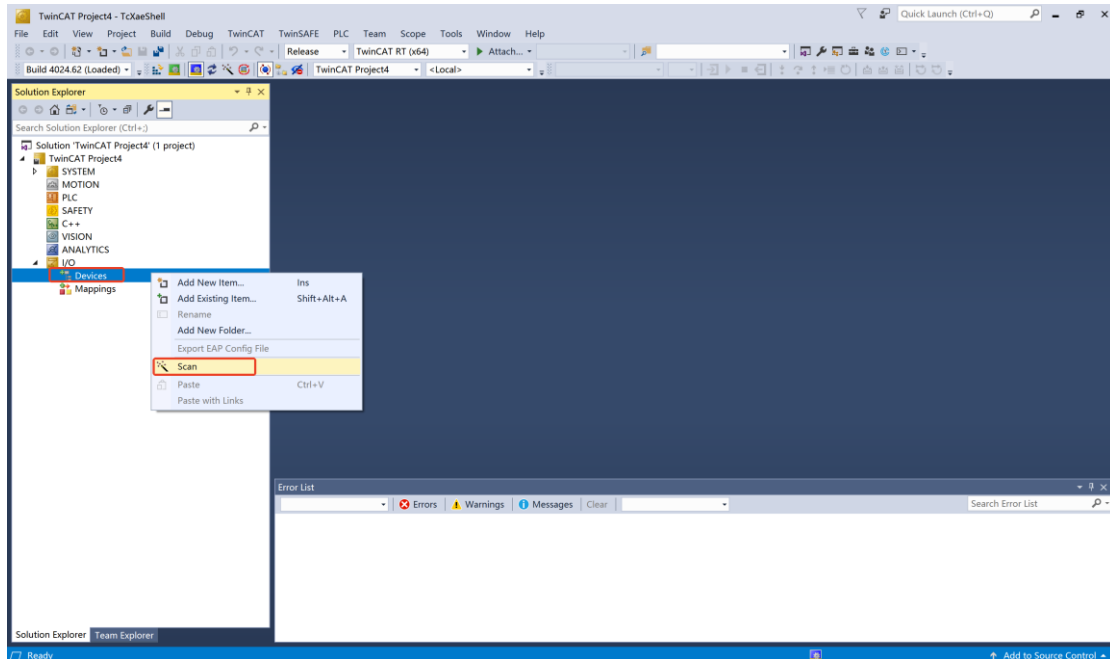

Click the Yes button in the interface to start the communication between BN-8033 and TwinCAT, and the left interface has already scanned for information about the module.

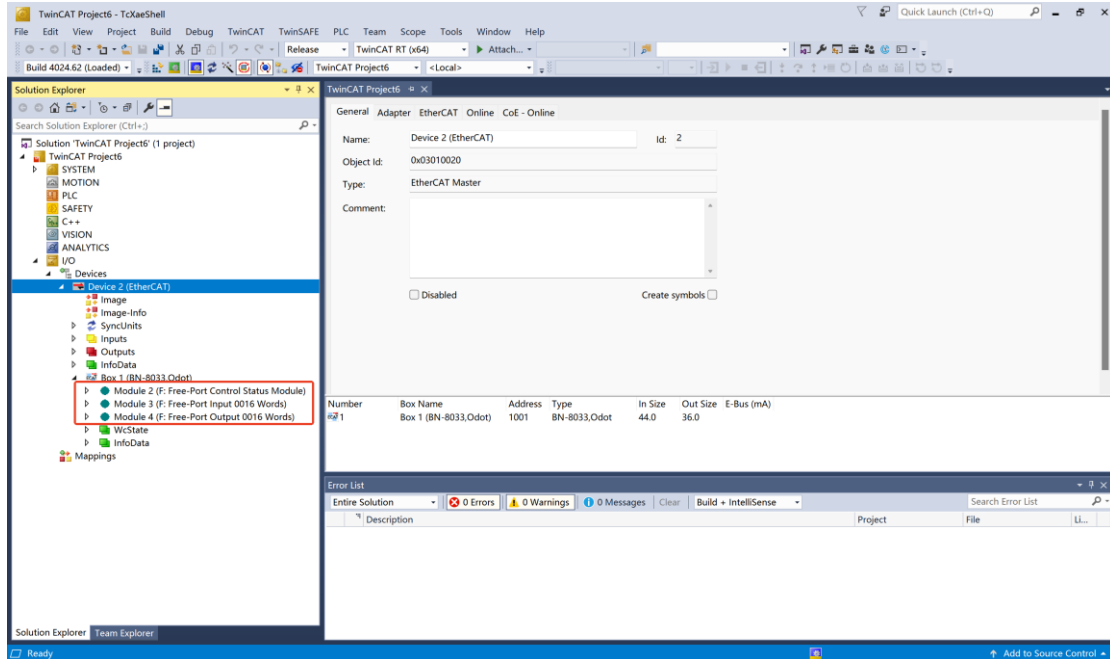

Once the scan is complete, it can see the configuration of the BN-8033 (the BT-5312 itself does not have process data, so it is not shown here). Select the read and write command to view the data collection values.

Set the control word and the number of control word of Free-Port control status module.

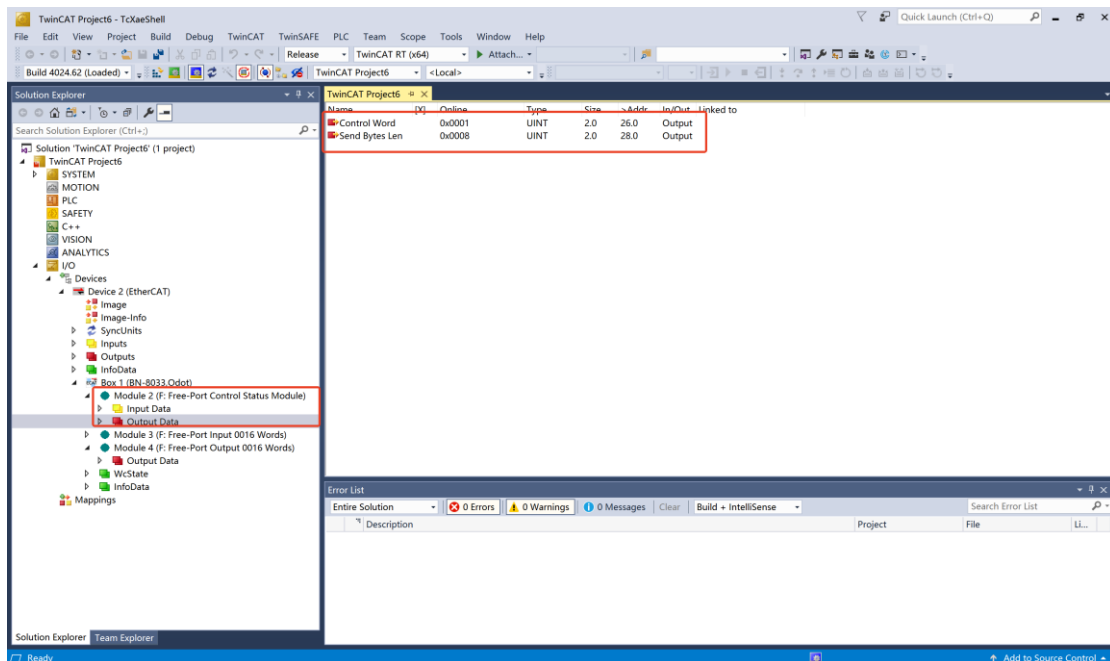

The request message sent:

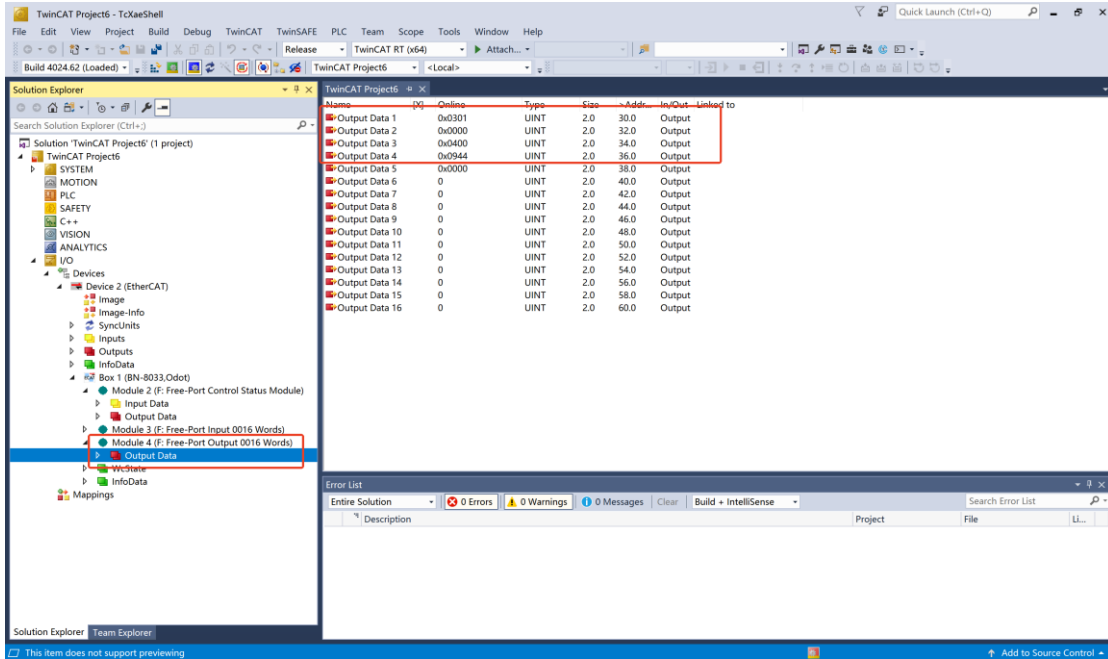

Slave device response data:

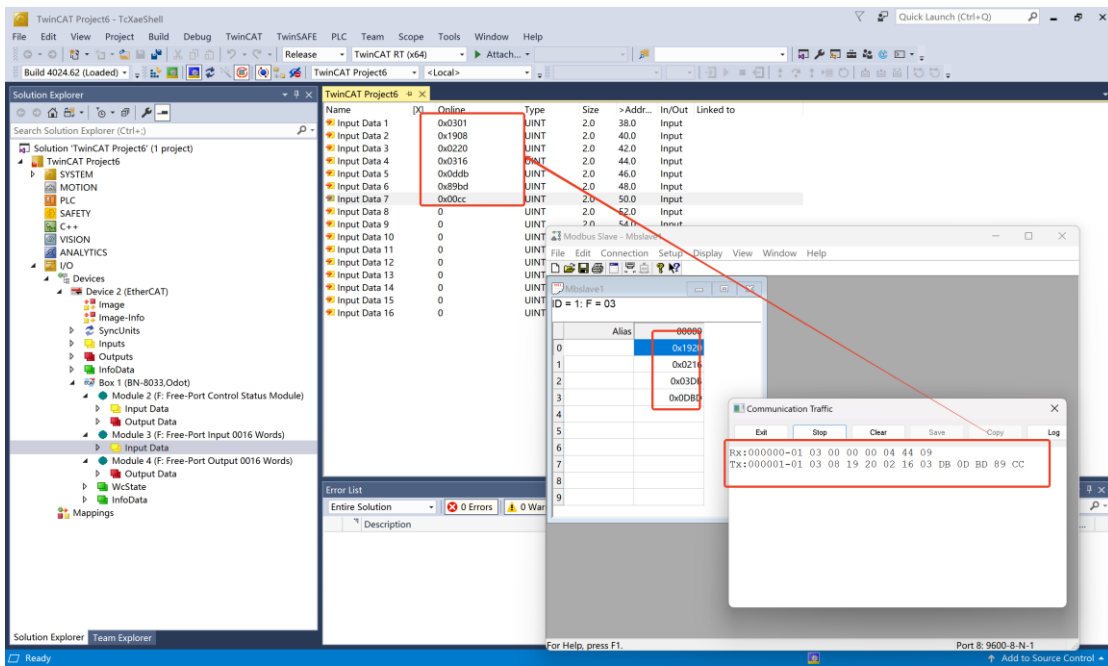

Odot Automation System Co., Ltd.

Plant 204, Comprehensive Bonded Zone, No. 261, Feiyun Avenue, Mianyang,
Sichuan, China.



Tel: +86-0816-2538289

Zip Code: 621000

Email: sales@odotautomation.com

Web: www.odot.com