

技术设变 Technical Design Change

标识Mark	设变内容 Changes	日期Date	审核Check

额定参数 (RATED PARAMETER)

1. 额定电压 (VOLTAGE) : DC24V
2. 功率 (WATTAGE) : 16.9W ± 10%
3. 电流 (CURRENT) : 0.7A ± 10%
4. 直流电阻 (DC RESISTANCE) : 34Ω ± 10% (20°C)
5. 工作循环 (DUTY CYCLE) : ON 1 Sec; OFF 6 Sec,
Max ON 30 Sec.
6. 绝缘等级 (INSULATION CLASS) : F 155°C

力量要求 (Strength requirements)

1. 测试条件 (Test conditions) : DC24V (20°C)

残留吸引力 RESIDUAL MAGNETISM: 小于弹簧回弹力

吸引力 ATTRACTION FORCE: 5MM ≥ 60gf

响应时间 RESPONSE TIME: 小于 0.03S

电气特性 ELECTRONICAL CHARACTERISTICS

1. 绝缘电阻 INSULATION RESISTANCE:
线圈和框架间 BETWEEN COIL AND FRAME 100MΩ 500DCV
2. 耐电压 DIELECTRIC STRENGTH:
线圈和框架间 600ACV (50/60Hz) 1 Sec
3. 温升 TEMPERATURE RISE:
Max 65°C (20°C DC24V ON 1 Sec, OFF 19 Sec 循环 1H.)
4. 寿命 LIFE: 30万周期测试无异常 (DC24V, ON 1 Sec, OFF 19 Sec)
5. 电线与线圈的强度 COIL AND LEAD WIRE STRENGTH: 1.0kgf
6. 工作环境 OPERATING ENVIRONMENTS: -5°C ~ 45°C / 5%RH ~ 85%RH
7. 符合 RoHS。

外形/尺寸图 DIMENSION/APPEARANCE:

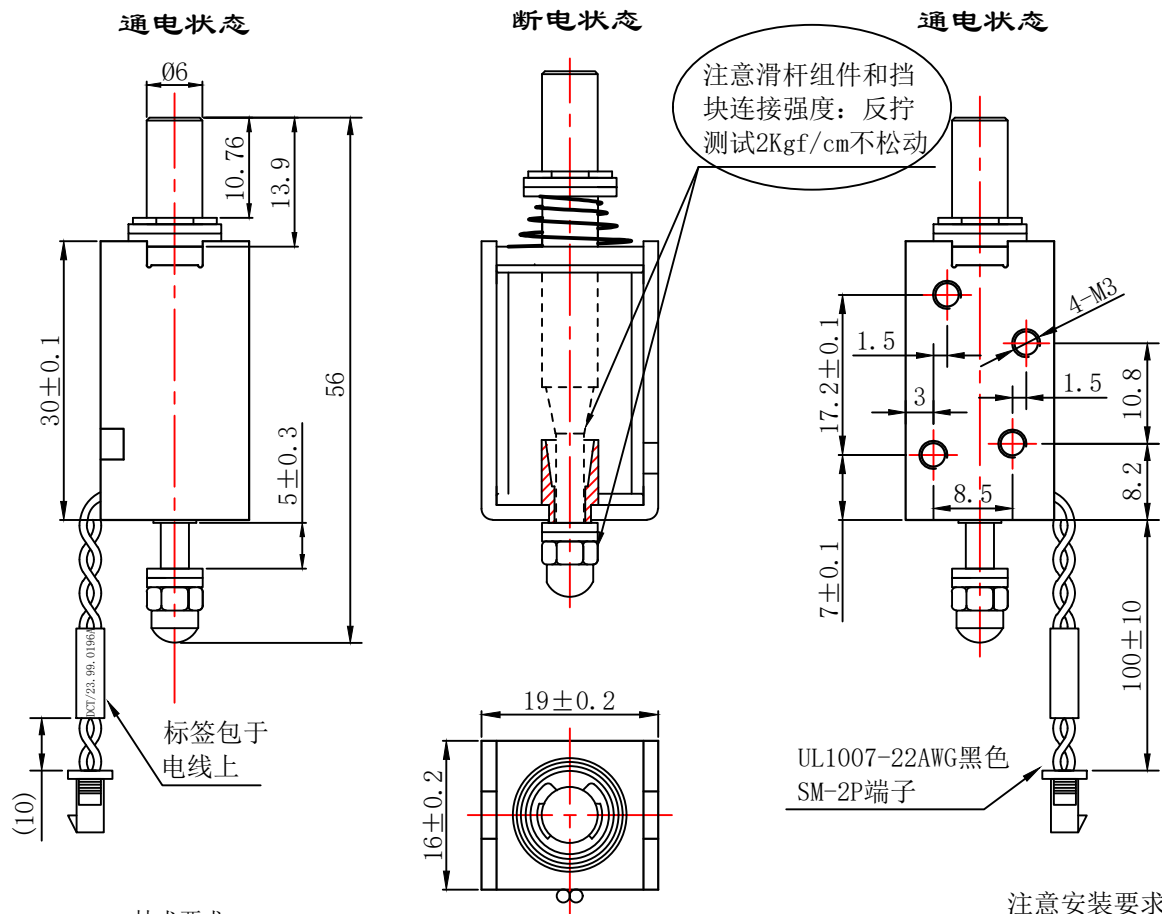

技术要求

- Technology requirements
1. 未注尺寸公差取上表公差值。 ULTERIORLY TOLERNCE .
 2. 滑杆动作灵活。 SOLENOID MUST BE LEAD FREE.

注意安装要求:

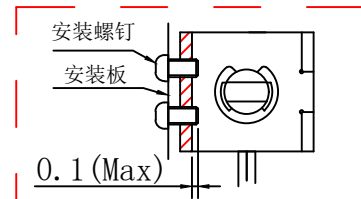

0-6	±0.1	检验抽样标准 Inspection Sampling Standard	常规尺寸	C=0抽样划计AQL=2.5
>6-30	±0.2			
>30-120	±0.3			
>120-315	±0.5			
>315-1000	±0.8			
>1000-2000	±1.2	未注参数 Unspecified parameters	重要尺寸 ★	C=0抽样划计AQL=0.4
角度Angles	±2°			
圆角Radius	R0.1			
倒角Chamfer	0.2*45°			
粗糙度Finish	√			
		外观尺寸 ▲	C=0抽样划计AQL=0.4	全检尺寸 ❁

SPECIFICATION 规格书		AST 东莞市亚思特科技有限公司				
		客户型号 (CUSTOMER PART NO.):				
Design 设计		亚思特型号 (AST PART NO.):		AS0630US-24A34	Units: mm 单位: mm	
Check 审核		Scale 比例	1:1	Edition 版本	A/0	
Confirm 批准		View 视图	☞	Page 页面	1/1	