

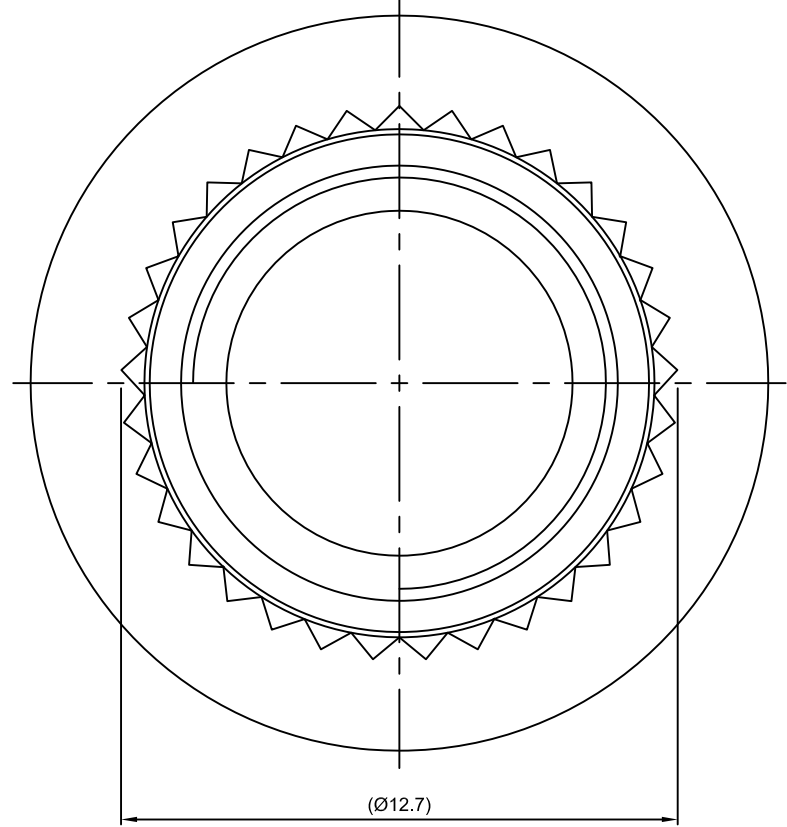

1.6

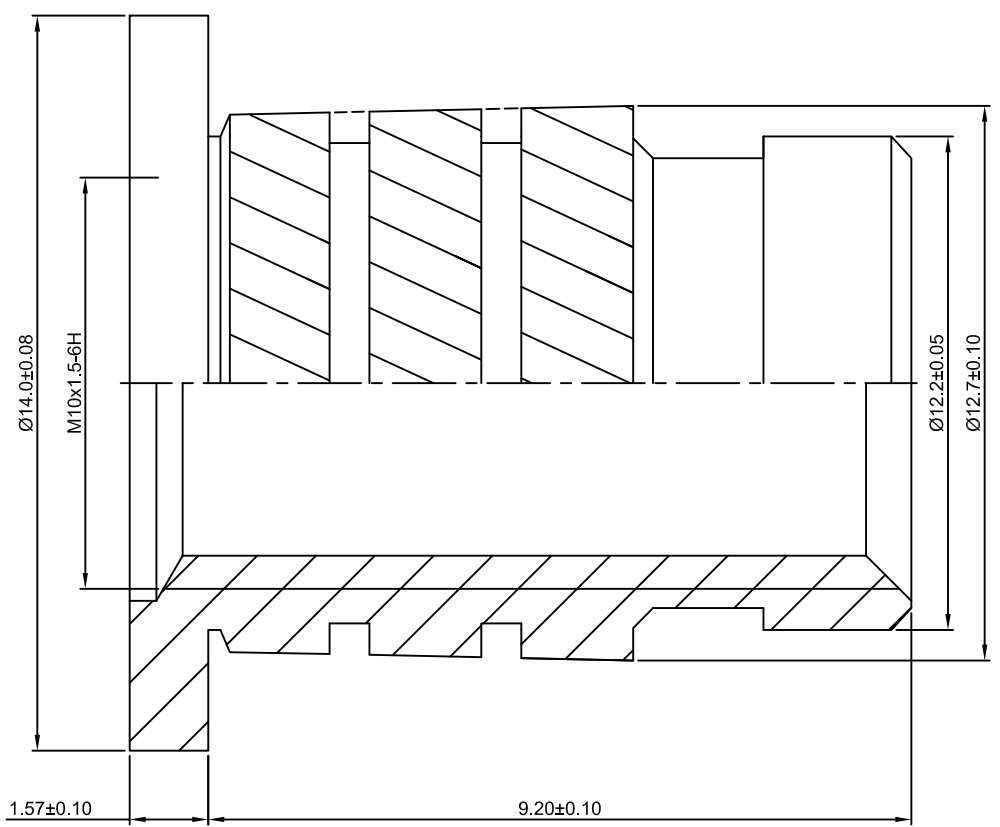

NOTES:
 1.Material:Brass C3604
 2.Finishing:Cleaning
 3.Remove all bur and sharpe angle , product is clean
 4.Unless otherwise specified,tolerance ±0.07mm

In-sail

UNIT: mm	
DIM Tol.:	Angle Tol.:
X. ±	X° ±
.X ±	.X° ±
.XX ±	.XX° ±
.XXX ±	.XXX° ±

①	1	Brass C3604	/	Cleaning	/	/
PART ITEM	QTY.	MATERIAL	NAME	Surface Treatment	Description	REF.
DR.	HA 2018.03.17	CHKD.	APPD.	Intended Use	 	SCALE
Sandum Precision Industry (China) Co., Ltd			TITLE			
The Drawing and Specification are the Property of Sandum Precision Industry (China) Co., Ltd . Without the Prior Written Permission of Top Management, any person or party except the Intended ones Is prohibited to Copy, Reproduce, Duplicate this document.			SPH-M10x9.2-HD14.0(HSR-B-M10)			
Drawing#:		P/N:	VERSION	SHEET		
LF1447		-	A	1 of 1		

F