

1 2 3

4 5 6

EC No.	EC Description	DR.
△	/	/

1.6

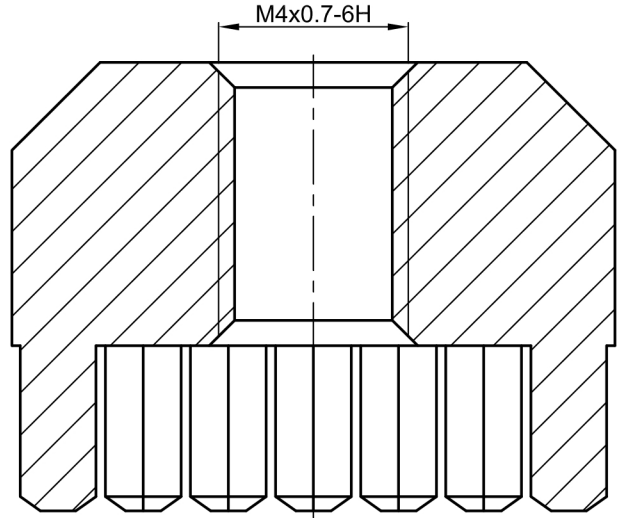
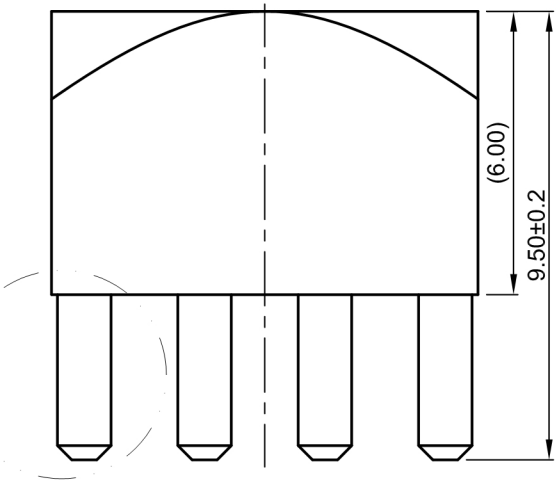
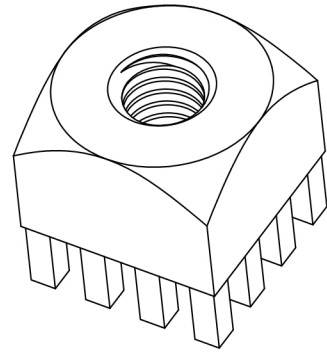
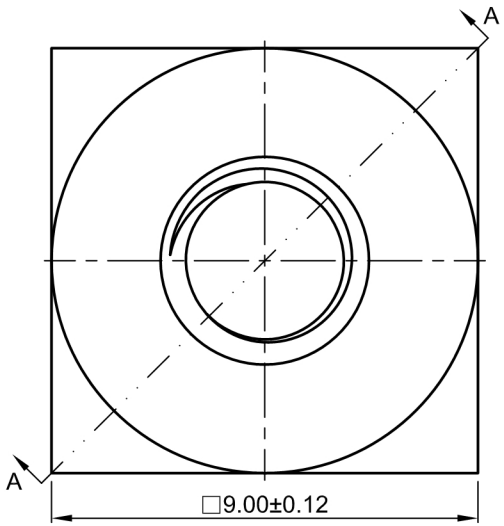

SECTION A-A

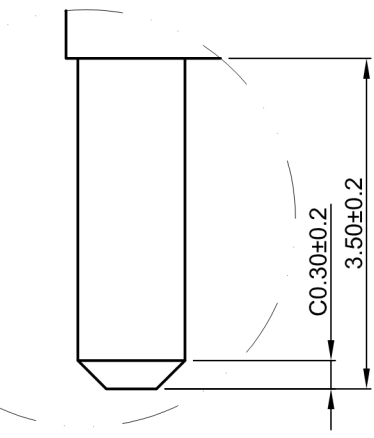
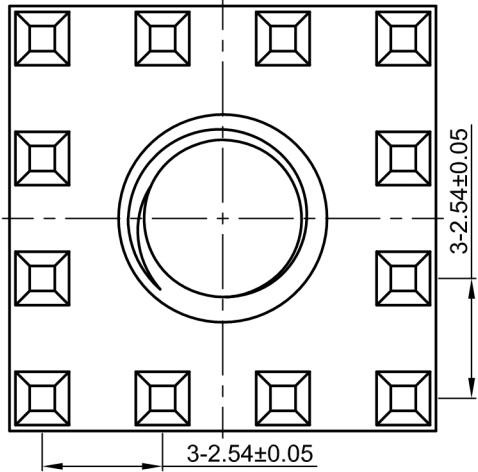

DETAIL B(2:1)

- NOTES:
1. Material: Brass C3604, comply with RoHS;
 2. Finish: Tin Plated;
 3. Packaging: Blister and Carton,
 4. Free of burrs and sharp edges;
 5. Thread must be checked with Go/No Go Gauge;
 6. Unless otherwise specified: ±0.12mm and angle ±2°.

In-sail®
力帆精密&力本五金

①	1	/	/	See Note 1	See Note 3	/
Part Item	QTY.	Name	Description	Material	Surface Treatment	Remark
DR.	LEX 2014.02.22	CHKD.	APPD.	Unit net weight ≈ / g		Rough weight ≈ / g

UNIT: mm

DIM Tol.: X. ±, .X ±, .XX ±, .XXX ±
Angle Tol.: X° ±, .X° ±, .XX° ±, .XXX° ±

Shenzhen In-sail Precision Parts Co., Ltd
The Drawing and Specification are the Property of Shenzhen In-sail Precision Parts Co., Ltd. Without the Prior Written Permission of Top Management, any person or party except the intended ones is prohibited to Copy, Reproduce, Duplicate this document, Please send email to sales@in-sail.com if you have any request.

TITLE: PE03-M4x9.5-□9.0ET

Drawing#: LFPE0302B00	P/N: /	REV. A	Sheet 1 of 1
-----------------------	--------	--------	--------------

1 2 3 4 5 6