

6	EC No.	EC Description	8	DR.
	△	/		/

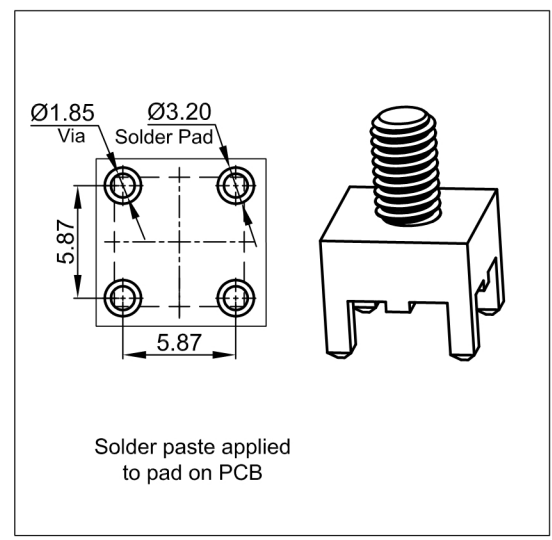
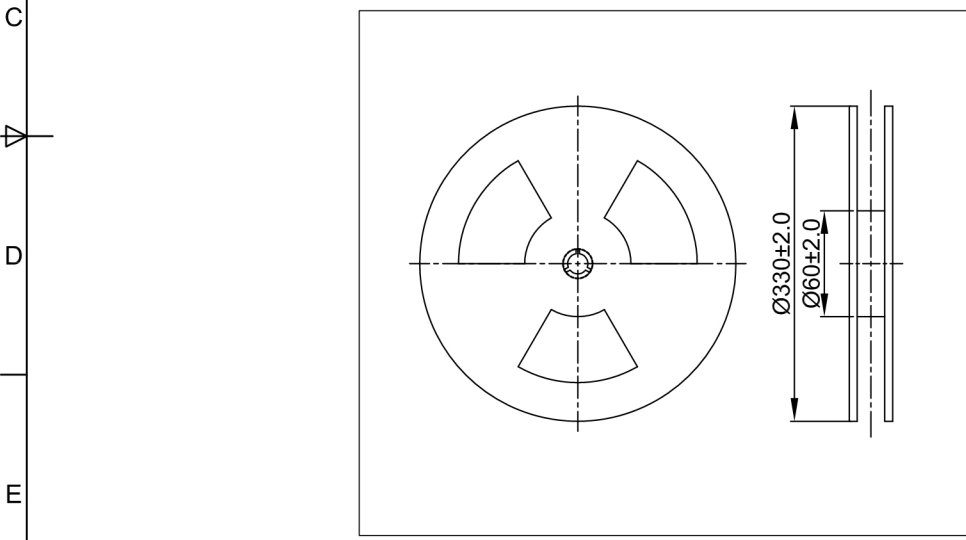

NOTES:
 1.Material:Brass C3604;
 2.Surface Treatment: Tin Plated;
 3.Remove all burrs and sharpe angle ,product is clean;
 4.Packaged on 13" recyclable reels, Tape width is 24mm
 Supplied with polyimide patch for vacuum pick up, Reels conform to IEC 60286-3 Package:350 pcs/Reel;
 5.RoHS Compliant.

In-sail®
 力帆精密&力本五金
 UNIT: mm

DIM Tol.:	Angle Tol.:
X ±	X° ±
.X ±	.X° ±
.XX ±	.XX° ±
.XXX ±	.XXX° ±

①	1	/	/	See Note 1	See Note 3	/
Part Item	QTY.	Name	Description	Material	Surface Treatment	Remark
DR.	MCZ 2023.08.16	CHKD.	APPD.	Unit net weight ≈ / g		Rough weight ≈ / g
Shenzhen In-sail Precision Parts Co.,Ltd			TITLE: PE21-M3x11.0-□7.0DT			
Drawing#: LFPE2101R00		P/N: /		REV. A	Sheet 1 of 1	

