

## G10 Series

### Subminiature Micro Switch



#### ■ Features

- ◆ Small compact size
- ◆ Long life and high reliability
- ◆ Variety of terminals
- ◆ Variety of levers optional
- ◆ Widely used in home appliances and industrial control

#### ■ Application

- ◆ Walkie Talkie
- ◆ Mouse
- ◆ Electric Knife
- ◆ Electric Stapler
- ◆ Telephone
- ◆ Calculator
- ◆ Mixer & Chopper
- ◆ Electric Pan
- ◆ Battery Charger
- ◆ Video Cassette Rewinder
- ◆ Cordless Phone
- ◆ Alarm
- ◆ Tester Machine
- ◆ Home Appliances

#### ■ Parameters:

Rating	P1	ENEC/CQC: 0.1A 48VDC/125VAC
		UL/cUL: 0.1A 48VDC/125VAC
	03	ENEC/CQC: 1A/3A 125VAC
		UL/cUL: 1A/3A 125VAC
Operating Frequency	Electrical	10~30 cycles/min
	Mechanical	120 cycles/min
Contact Resistance (Initial Value)		100mΩ Max. (Depends on P/N)
Insulation Resistance (at 500 VDC)		100MΩ Min.
Dielectric Strength	Between terminals	600VAC 50~60Hz for 1 Min.
	Between terminals and housing	600VAC 50~60Hz for 1 Min.
Operating Temperature		-40°C~+85°C
Operating Humidity		85%RH Max.
Service Life	Electrical	10,000/50,000 cycles (Depends on P/N)
	Mechanical	1,000,000 cycles
Unit Net Weight		About 0.5g (Straight PCB type without lever)

## G10 Series Micro Switch Ordering Instruction

G10	P1	150	S	00	A	XX	T001	U
Switch Type	Electrical Rating	Max Operating Force at Pin Plunger	Terminal Type	Lever Type	Circuitry	Special Designator	Custom Code	LOGO
G10 Series Micro Switch	P1 ENEC/CQC: 0.1A 48VDC 125VAC UL/cUL: 40T85 μ 5E4 0.1A 48VDC/125VAC	090 90gf Max	S Solder Terminals	00 No Lever Pin Plunger	A SPDT	General	General	U Unionwell
	03 ENEC/CQC: 1A/3A 125VAC UL/cUL: 40T85 μ 5E4 1A/3A 125VAC	150 150gf Max	P Straight PCB Terminals	01 10.55mm Short Straight Lever 0.41"		A Gold Plated	TO Customized according to requirements, the code format is T+serial number XXX, for example: T001	... Other
			Q Snap in PCB Terminals	02 13.55mm Std. Straight Lever 0.53"		00 Non-Halogen Material		
			M Short Solder Terminals	03 18.0mm Long Straight Lever 0.71"				
			R Right Angled PCB Terminals	05 11.8mm Simulated Roller Lever 0.46"				
			L Left Angled PCB Terminals	07 14.9mm Small Simulated Roller Lever 0.58"				
			K Long Solder Terminals	09 30.0mm Long Straight Lever				
			... Special Terminals	10 12.80mm Roller Lever				
				... Special Lever				

## Terminal Type

◆ Terminal thickness: 0.6mm

S Type Straight Solder Terminals	P Type Straight PCB Terminals	Q Type PCB snap-in (clip) Terminals
M Type Short Solder Terminals	R Type Right Angled PCB Terminals	L Type Left Angled PCB Terminals
K Type Long Solder Terminals	■ Circuit Configuration	

## Mounting Hole Dimensions

(Unit:mm)

Mounting Hole Dimensions	Mounting Hole Dimensions of PCB Terminals
Mounting Hole Dimensions of Right Angled PCB Terminals	Mounting Hole Dimensions of Left Angled PCB Terminals

## Overall Dimensions and Operating Characteristics

### ◆ G10□□-□P00AU

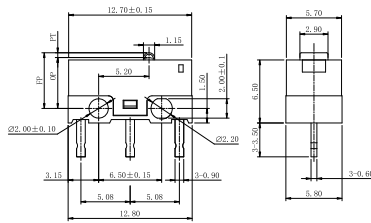
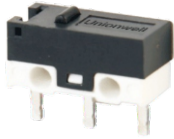

OF Max. (gf)	RF Min. (gf)	PT Max. (mm)	OT Min. (mm)	DT Max. (mm)	FP Max. (mm)	OP (mm)
-090	90	15	0.65	0.2	0.2	6.0
-150	150	20				5.5±0.3

### ◆ G10□□-□P01AU

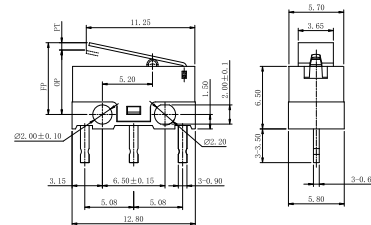

OF Max. (gf)	RF Min. (gf)	PT Max. (mm)	OT Min. (mm)	DT Max. (mm)	FP Max. (mm)	OP (mm)
-090	40	6	2.5	0.3	0.6	8.0
-150	60	10				6.25±0.8

### ◆ G10□□-□P02AU

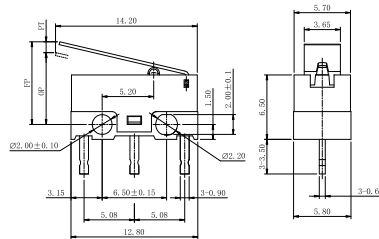

OF Max. (gf)	RF Min. (gf)	PT Max. (mm)	OT Min. (mm)	DT Max. (mm)	FP Max. (mm)	OP (mm)
-090	30	4	3.4	0.3	0.8	8.8
-150	50	8				6.35±0.9

### ◆ G10□□-□P03AU

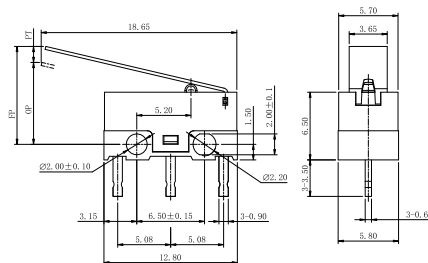
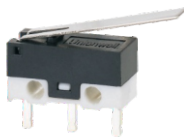

OF Max. (gf)	RF Min. (gf)	PT Max. (mm)	OT Min. (mm)	DT Max. (mm)	FP Max. (mm)	OP (mm)
-090	40	3	4.0	0.5	1.0	10.0
-150	50	5				7.5±1.5

### ◆ G10□□-□P05AU

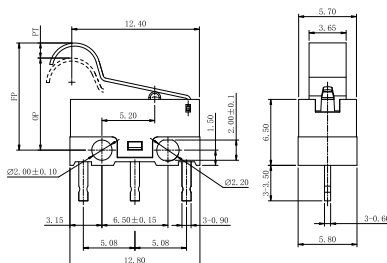

OF Max. (gf)	RF Min. (gf)	PT Max. (mm)	OT Min. (mm)	DT Max. (mm)	FP Max. (mm)	OP (mm)
-090	40	5	3.0	0.3	0.7	12.0
-150	50	8				9.5±0.8

## ◆ G10□□-□P07AU

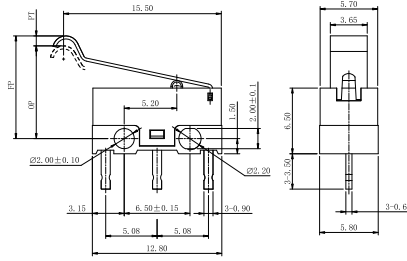

	OF Max. (gf)	RF Min. (gf)	PT Max. (mm)	OT Min. (mm)	DT Max. (mm)	FP Max. (mm)	OP (mm)
-090	30	5	3.5	0.3	1.1	11.5	8.2±1.0
-150	50	8					

## ◆ G10□□-□P09AU

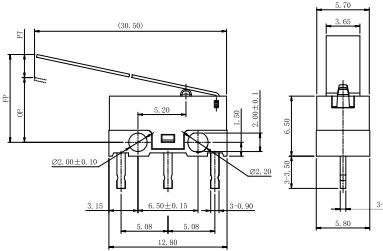

	OF Max. (gf)	RF Min. (gf)	PT Max. (mm)	OT Min. (mm)	DT Max. (mm)	FP Max. (mm)	OP (mm)
-090	15	2	6.9	0.4	2.5	14.0	8.2±2.1
-150	23	3					

## ◆ G10□□-□P10AU

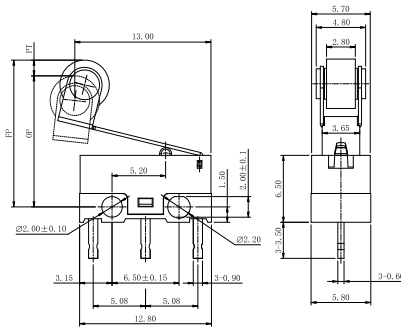

	OF Max. (gf)	RF Min. (gf)	PT Max. (mm)	OT Min. (mm)	DT Max. (mm)	FP Max. (mm)	OP (mm)
-090	35	3	5.5	0.3	0.8	16.5	13.0±1.3
-150	50	6					