

## GT07 Series

### Mechanical Keyboard Switch-4mm Travel



#### ■ Features

- ◆ Compact structure, high reliability, long life
- ◆ Dustproof design
- ◆ SPDT structure patent design
- ◆ Long life, high reliability
- ◆ Touch contact structure

#### ■ Applications

- ◆ Election machines
- ◆ Process equipment
- ◆ Machine interface equipment

#### ■ Specification and Parameters

Electrical Characteristics	Rating	12VDC/AC Max. 10mA VDC/AC Max.
	Contact Resistance	200mΩ Max. (25mΩ Typical) (Initial Value)
	Insulation Resistance	100MΩ Min
	Voltage Resistance	AC 500V (50-60Hz) 1 Min
	Electrical Life	Over 10,000,000 cycles (Load)
Parameters	Bounce Time	Operation Speed at 400mm/sec 5 msec
	Operating Force	See Detail Spec
	Pre-travel	PT1=1.0±0.4mm, PT2=1.6±0.4mm
	Total Travel	4.0+0/-0.3mm
	Mechanical Life	Over 10,000,000 cycles (No Load)
	Operating Temperature	-40°C~+80°C
	Operating Humidity	≤85% RH

#### ■ GT07 Series Keyboard switch Ordering Instruction

GT07	T001	U
Switch Type	Custom Code	LOGO
GT07 Series Keyboard Switch	General	U Unionwell
	T001 Customized according to requirements, the code format is T+serial number XXX, for example: T001	... Other
	... Other	

## ■ Dimensions

(Unit:mm)

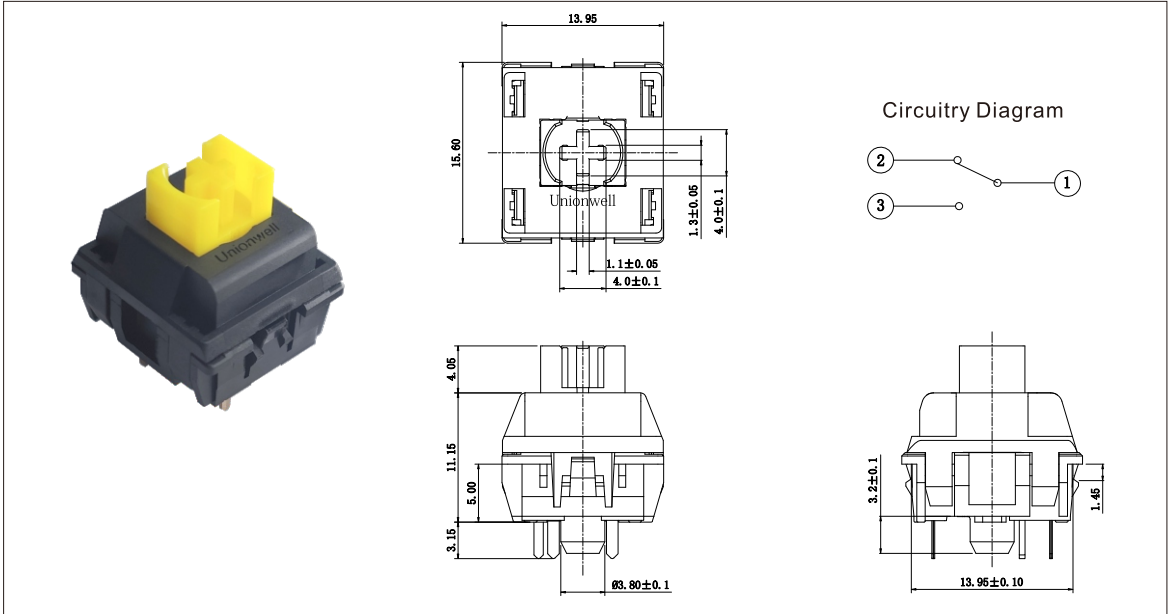

## ■ Mounting Options

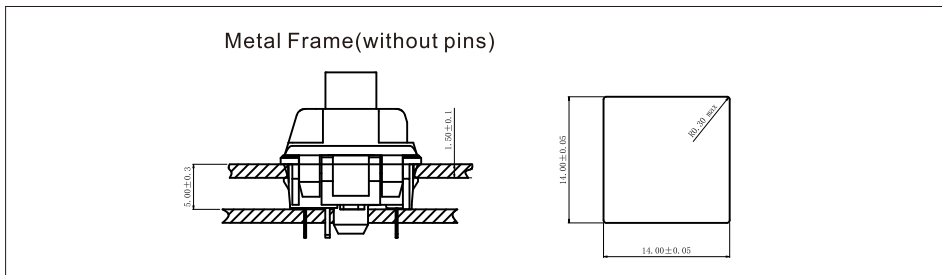

## ■ Circuitry Board Layouts

- ◆ Keyboard switch without fixation pins

Gride line spacing=1.27mm

