

GT06 Series

Mechanical Keyboard Switch-4mm Travel



■ Features

- ◆ Desktop profile, 0.60 inch (15.2mm) from PCB (no keycap)
- ◆ Switch option: linear, tactile, clicky
- ◆ Frame mount
- ◆ Long life to 80 million operation cycles
- ◆ Equipped with light pipe, to diffuse light and make it not dazzling
- ◆ 12VAC/DC maximum
- ◆ Current rating: 10mA
- ◆ Insulation resistance: < 100MΩ under 100VDC

■ Applications

- ◆ Computer keyboards
- ◆ Cash counters
- ◆ Industrial equipment
- ◆ Man-machine interfaces

■ Specification and Parameters

Electrical Characteristics	Rating	12VDC/AC max. 10mA AC/DC max.
	Contact Resistance	200mΩ Max. (25mΩ Typical) (Initial Value)
	Insulation Resistance	100MΩ Min
	Voltage Resistance	AC 500V (50-60Hz) 1 Min
	Electrical Life	Over 80,000,000 cycles(load)
	Bounce Time	5 msec (Operation speed at 400mm/Sec)
Parameters	Operating Force	See Detail Spec
	Pre-travel	2.0±0.4mm
	Total Travel	4.0 ⁺⁰ _{-0.3} mm
	Mechanical Life	Over 100 Million cycles (Under No Load)
	Operating Temperature	-40°C~+80°C
	Operating Humidity	≤85% RH

GT06 Series Keyboard Switch Ordering Instruction

GT06	A	1	A	N	W	T001	U
Switch Type	Contact Material	Code of Operating Force	Operating Characteristics and Key Style	LED Diode	PCB Mounting Pins	Custom Code	LOGO
GT06 Series Key Switch	A Au Alloy	1 OF=60±20gf (60#or601#Spring)	A Momentary, Single Pole, Standard switch, Linear, Black Key	N Single Color	W With Pins	General	U Unionwell
	B Ag Alloy	2 OF=80±25gf (80#Spring)	B Momentary, Single Pole, Standard switch, Soft Tactile, Brown Key	F Full Color RGB	N No Pins (With Metal Frame)		... Other
	R Others Up to Customer	3 OF=120±25gf (120#Spring)	D Momentary, Single Clicky Feel, Blue Key	T SMT LED	Customized according to requirements, the code format is T+serial number XXX, for example: T001		
	...		E Momentary, Single Pole, Standard switch, Linear, Black Key	... Others		... Other	

Unionwell

■ Dimensions

(Unit:mm)

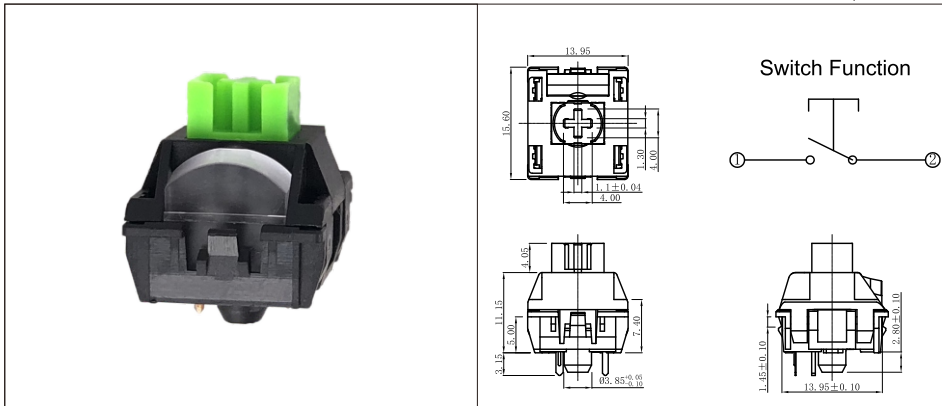

■ Mounting Options

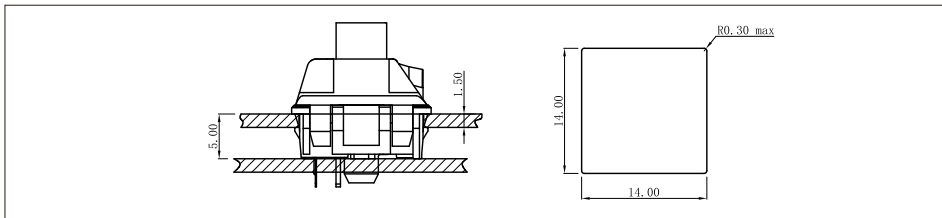

■ Circuit Board Layouts

◆ Keyboard Switch without Fixation Pins

Gride line spacing=1.27mm

