

G303 Series

Sealed Subminiature Micro Switch

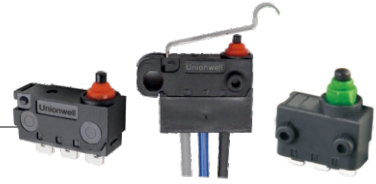

■ Features

- ◆ Designed for water and dust tight (IP67)
- ◆ Small compact size
- ◆ Global safety approvals
- ◆ Long life and high reliability
- ◆ Variety of levers
- ◆ Wide range of wiring terminals
- ◆ Widely used in automotive electronics, appliance and industrial control designs

■ Application

- ◆ Car
- ◆ Air-Conditioner
- ◆ Communication
- ◆ Electric Toothbrush
- ◆ Toys
- ◆ Bicycle

■ Parameters

Rating		0.1A, 125/250VAC; 3A/12VDC; 0.1A/48VDC; μ 1E5
Operating Frequency	Electrical	0.1A, 120 cycles/min 3A, 10~30 cycles/min
	Mechanical	120 cycles/min
Contact Resistance (Initiative)		100m Ω Max. (without wire type)
Insulation Resistance (at 500VDC)		100M Ω Min.
Vibration Durability		10~55Hz, move 0.75mm (p-p)
Dielectric Strength		500VAC (50~60Hz)
Operating Temperature		-40°C~+85°C
Operating Humidity		85%RH Max.
Service Life	Electrical	Min. 100,000 cycles (Depend on part NO.)
	Mechanical	Min. 500,000 cycles

■ Circuit

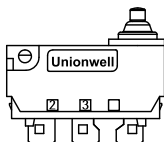

Circuit

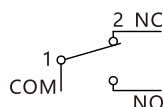

G3 Series Micro Switch Ordering Instruction

G3	03	R	130	S	00	A	
Switch Type	Electrial Rating	Resistor Configuration	Operating Force at Pin Plunger,Max	Terminal Style	Lever Type		Circuit
03	0.1A 125/250VAC 48VDC:3A 12VDC μ40T85 1E5	Without inner resistor	130 130gf Max. Use 130# spring	E	00 No lever Pin plunger	31 Simulated roller (for A, A1, M3 types)	A SPDT
		R With inner resistor(with wires)		G Molded lead wires on left side (plunger side)	01 Leaf lever (for A, A1, M3 types)	35 35# Lever (for A, A1, M3 types)	B SPST -NC
				F Molded lead wires on right side(away from plunger side)	02 Straight leaf lever (for A, A1, M3 types)	36 36# Lever (for A, A1, M3 types)	C SPST -NO
				S Solder terminals	03 03# Straight lever (only for C case)	37 37# Lever (for A, A1 types with PHA waterproof case)	
				K Long solder terminals	04 04# Lever (for A, A1, M3 types)	38 38# Lever (for C1, C2 types)	
				N None-hole short solder terminals	05 Simulated roller (for A, A1, M3 types)	41 41# Lever (for A, A1, M3 types)	
				P Straight PCB terminals (0.6mm width)	08 Straight leaf lever (only A2 type)	45 45# Lever (for A, A1, M3 types)	
				R Right side PCB terminals	09 Mini simulated roller lever (for A, A1, M3 types)	79 79# Lever (for A, A1, M3 types)	
				L Left side PCB terminals	10 10# Lever (for A, A1 types with PHA waterproof case)	93 93# lever (Only for A2 type)	
				I Big solder terminals	13 13# Lever (only for Type)	... Other	
				J Left right straight PCB terminals	15 Upside down simulated roller lever (for A, A1, M3 types)		
				A Left side fork type terminals	21 21# Staight lever (only for C type case)		
				B Right side fork type terminals	22 22# Lever (for A, A1, M3 types)		
				Q 2.5 type terminals Wide 2.5mm, length 7.5mm	23 23# Lever (only for C1M3)		
				D 2.5 type 2#terminals Wide2.5mm length5.15mm	25 25# Lever (for A, A1, M3 types)		
				W None hole solder terminals	28 28# Lever (for A, A1, M3 types)		
				U 5#PCB NC terminal			
				V 6#PCB NC terminal			

1	A	E	A	280	T001	U
Shape and Posts	Posts Dimension	AWG Type (for wire type only)	AWG Number (for wire type only)	Wires Length	Custom Code	LOGO
1 A type no post	Standard post 1. A, A1, A2, B types 2.60mm X 5.0mm 2. M3 type 2.95mm X 1.4mm 3. C1, D1 types 2.95mm X 1.5mm 4. C1 M3 type 3.0mm X 1.5mm	Without wire	Without wire	Standard length (300mm)	General model	U Unionwell
2 A type left side posts		M 18# Only for molded lead wires downward types			T001 Customization the customized code is T + serial number, suchas: T001	
3 A type right side posts			E 20# For A, A1, M3 molded Lead wires downward types and C type with 2 wires types	280 280mm length		T355 SPST-NC Color of wires, COM (black) NC (gray) resistance value RC: 220Ω R4: 3300Ω FP: 220Ω OP: 3520Ω
4 B type no post		A UL1007			... Other	
5 B type left posts	C UL1430		T354 SPST-NC Color of wires, COM (black) NC (gray) resistance value RC: 1500Ω R4: 1800Ω FP: 1500Ω OP: 3300Ω			
6 B type right side posts		D UL1061		T314 SPST-NO Color of wires, COM (black) NC (gray) resistance value RC: 1620Ω R4: 5110Ω FP: 6730Ω OP: 1620Ω		
7 M3 type posts	F AVSS		T319 SPST-NO Color of wires, COM (black) NC (gray) resistance value RC: 220Ω R4: 3300Ω FP: 3520Ω OP: 220Ω			
8 A type two sides posts		H 26#		T564 SPST-NO Color of wires, COM (black) NC (gray) resistance value RC: 150Ω R4: 330Ω FP: 480Ω OP: 150Ω		
9 B type two sides posts	I 28#		... Other			
12 C1 type two sides posts		... Other		... Other		
13 C1 type no post	K Φ 2.95mm X 5.0mm posts. (only for C1 type)		... Other			
14 C1 type left posts		J Φ 2.6mm X 1.4mm posts. (only for A2 type)		... Other		
15 C1 type right posts	... Other		... Other			
16 D1 type no post		... Other		... Other		
17 D1 type left side posts	... Other		... Other			
18 D1 type right side posts		... Other		... Other		
19 D1 type two sides posts	... Other		... Other			
28 A type no post		... Other		... Other		
29 A type left side posts	... Other		... Other			
30 A type right side posts		... Other		... Other		
31 A type two sides posts	... Other		... Other			
47 C1M3 type posts		... Other		... Other		
48 A2 type posts	... Other		... Other			
49 A2 type posts		... Other		... Other		
50 A2 type posts	... Other		... Other			
51 A2 type posts		... Other		... Other		
52 A2 type posts	... Other		... Other			
53 A2 type posts		... Other		... Other		
54 A2 type posts	... Other		... Other			
55 A2 type posts		... Other		... Other		
... Other	... Other		... Other			



Basic Mounting Dimensions and Operating Characteristics

A shape	A1 shape
A2 shape	B shape
C1 shape	C1M3 shape
D1 shape	M3 shape

Shape and Posts

A type basic shape	A1 type basic shape	A2 type basic shape	B type basic shape	M3 type basic shape

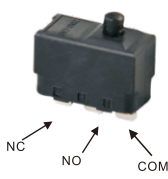
■ Shape and Posts

C1 type basic shape	D1 type basic shape
 <p style="text-align: center;">C1 type</p>	 <p style="text-align: center;">D1 type</p>
C1M3 Shape	
	

■ Switch Terminal Type (can be customized)

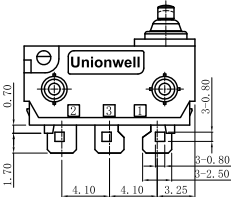
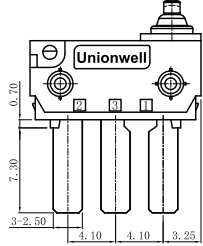
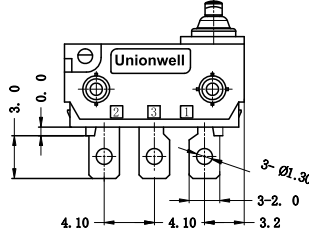
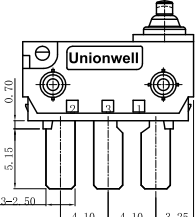
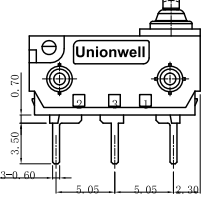
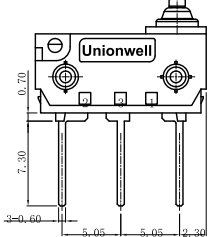
S Type	Q Type	K Type
		
D Type	P Type	J Type
		

P1 Type	I Type	R Type
L Type	A Type	B Type
W Type	U Type	V Type

■ Wires Leads Type

Wires leads to bottom	Wires leads to plunger side	Wires leads to opposite to plunger side
<p>COM:AVSS 0.3 mm² Black NO:AVSS 0.3 mm² Blue NC:AVSS 0.3 mm² Gray</p>	<p>COM:AVSS 0.3 mm² Black NO:AVSS 0.3 mm² Blue NC:AVSS 0.3 mm² Gray</p>	<p>COM:AVSS 0.3 mm² Black NO:AVSS 0.3 mm² Blue NC:AVSS 0.3 mm² Gray</p>

■ Switch Lever Type (can be customized)

Without Lever	01# Lever	02# Lever
03# Lever	04# Lever	05# Lever
09# Lever	37# Lever	15# Lever
22# Lever	23# Lever	25# Lever
28# Lever	35# Lever	36# Lever

38# Lever	41# Lever	79# Lever
45# Lever		93# Lever

■ Posts Type (can be customized)

A shape: Ø2.60X5.00mm posts	A1 shape: Ø2.60X5.00mm posts	<p>■ Posts Identification</p> <p>Top View - Post Direction Identification</p>
A2 shape: Ø2.60X5.00mm posts	B shape: Ø2.60X5.00mm posts	
C1: Ø2.60X5.00mm posts	C1M3: Ø2.60X5.00mm posts	D1: Ø2.60X5.00mm posts

M3: Ø2.60X5.00mm posts	A shape of type A: Ø2.20X0.90mm posts	A shape of type B: Ø2.50X1.50mm posts
A shape of type C: Ø2.60X2.50mm posts	A shape of type F: Ø2.60X3.80mm posts	A shape of type H: Ø2.60X2.00mm posts

■ Dimensions and Operating Characteristics

◆ G3□□-□□□S00A1U

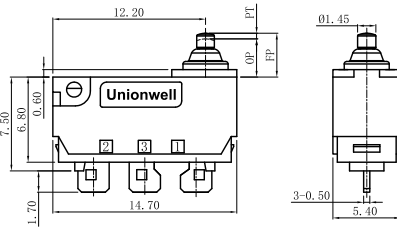

OF Max (gf)	RF Min (gf)	PT Max (mm)	OT Min (mm)	DT Max (mm)	FP Max (mm)	OP (mm)
-130	130	13	0.8	0.8	0.2	3.65

◆ G3□□-□□□S01A1U

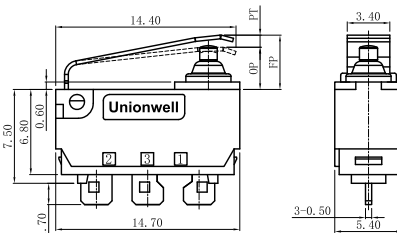

OF Max (gf)	RF Min (gf)	PT Max (mm)	OT Min (mm)	DT Max (mm)	FP Max (mm)	OP (mm)
-130	250	30	3	0.8	0.5	5.7

◆ G3□□-□□□S02A1U

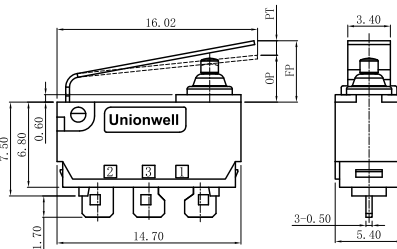

OF Max (gf)	RF Min (gf)	PT Max (mm)	OT Min (mm)	DT Max (mm)	FP Max (mm)	OP (mm)
-130	250	25	3.5	1.35	0.6	6.8

◆ G3□□-□□□S05A1U

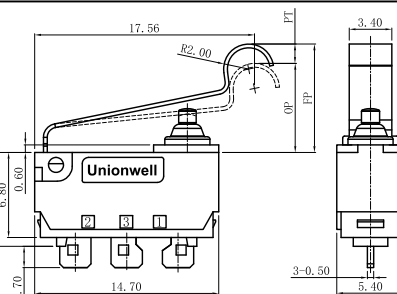

OF Max (gf)	RF Min (gf)	PT Max (mm)	OT Min (mm)	DT Max (mm)	FP Max (mm)	OP (mm)
-130	180	20	3.8	1.5	0.7	9.8

■ Dimensions and Operating Characteristics

◆ G3□□-□□□S00A3U

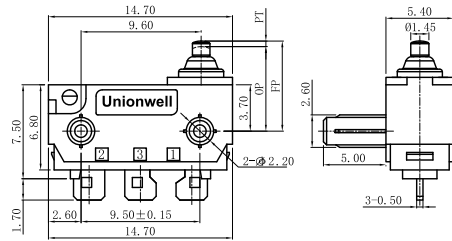

OF Max (gf)	RF Min (gf)	PT Max (mm)	OT Min (mm)	DT Max (mm)	FP Max (mm)	OP (mm)
-130	130	13	0.8	0.2	7.35	6.75±0.2

◆ G3□□-□□□S01A3U

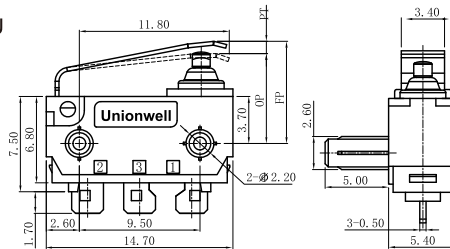

OF Max (gf)	RF Min (gf)	PT Max (mm)	OT Min (mm)	DT Max (mm)	FP Max (mm)	OP (mm)
-130	250	30	3	0.8	0.5	9.4
						7.1±0.5

◆ G3□□-□□□S02A3U

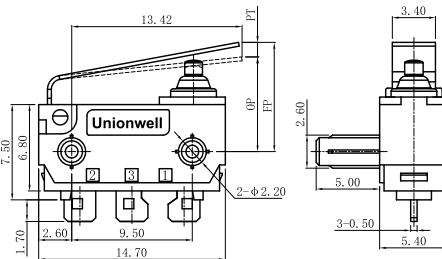

OF Max (gf)	RF Min (gf)	PT Max (mm)	OT Min (mm)	DT Max (mm)	FP Max (mm)	OP (mm)
-130	250	25	3.5	1.35	0.6	10.5
						7.4±0.6

◆ G3□□-□□□S05A3U

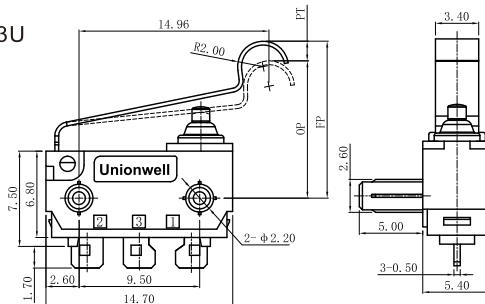

OF Max (gf)	RF Min (gf)	PT Max (mm)	OT Min (mm)	DT Max (mm)	FP Max (mm)	OP (mm)
-130	180	20	3.8	1.5	0.7	13.5
						10.7±0.7

◆ G3□□-□□□S09A3U

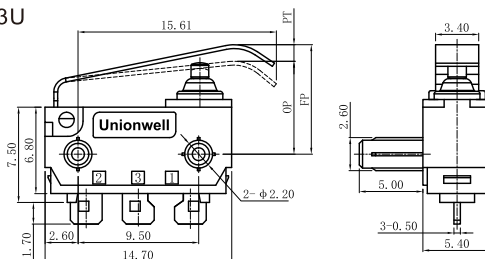

OF Max (gf)	RF Min (gf)	PT Max (mm)	OT Min (mm)	DT Max (mm)	FP Max (mm)	OP (mm)
-130	195	30	3.5	1.3	0.6	10.8
						7.3±0.6

◆ Dimensions and Operating Characteristics

◆ G3□□-□□□S15A3U

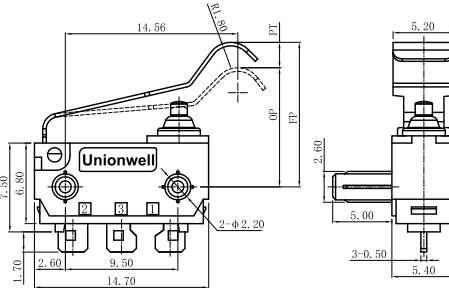

OF Max (gf)	RF Min (gf)	PT Max (mm)	OT Min (mm)	DT Max (mm)	FP Max (mm)	OP (mm)
-130	200	20	3.8	1.5	0.7	13.8

◆ G3□□-□□□S22A3U

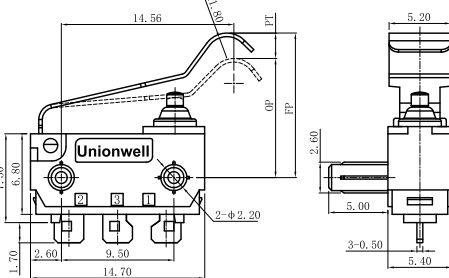

OF Max (gf)	RF Min (gf)	PT Max (mm)	OT Min (mm)	DT Max (mm)	FP Max (mm)	OP (mm)
-130	200	20	3.8	1.5	0.7	13.8

◆ G3□□-□□□S25A3U

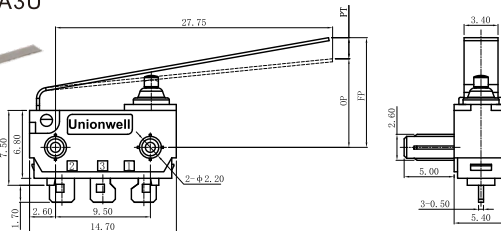
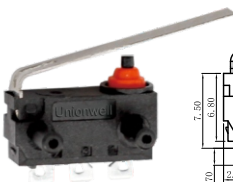

OF Max (gf)	RF Min (gf)	PT Max (mm)	OT Min (mm)	DT Max (mm)	FP Max (mm)	OP (mm)
-130	150	25	5.5	1.35	1.5	13

◆ G3□□-□□□S28A3U

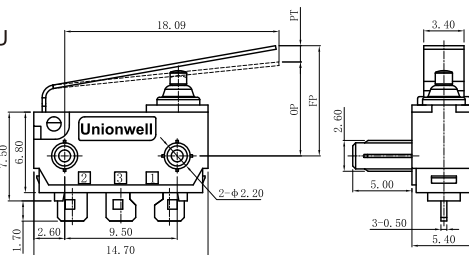

OF Max (gf)	RF Min (gf)	PT Max (mm)	OT Min (mm)	DT Max (mm)	FP Max (mm)	OP (mm)
-130	200	25	4.5	1.5	1	11.65

◆ G3□□-□□□S35A3U

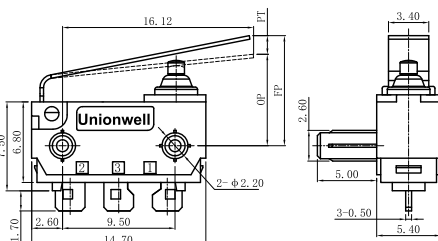

OF Max (gf)	RF Min (gf)	PT Max (mm)	OT Min (mm)	DT Max (mm)	FP Max (mm)	OP (mm)
-130	200	25	4.4	1.5	1	11.45

◆ Dimensions and Operating Characteristics

◆ G3□□-□□□S36A3U

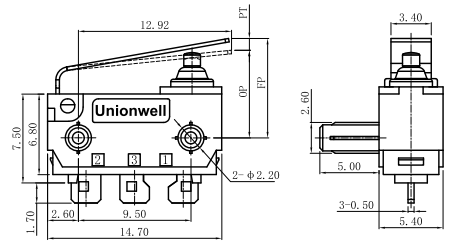

OF Max (gf)	RF Min (gf)	PT Max (mm)	OT Min (mm)	DT Max (mm)	FP Max (mm)	OP (mm)	
-130	250	25	3.4	1.3	0.6	10.6	7.2±0.6

◆ G3□□-□□□P41A3U

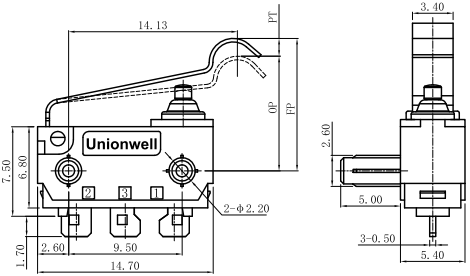

OF Max (gf)	RF Min (gf)	PT Max (mm)	OT Min (mm)	DT Max (mm)	FP Max (mm)	OP (mm)	
-130	200	50	3.5	1.2	0.6	13	9.5±0.7

◆ G3□□-□□□E37C1U

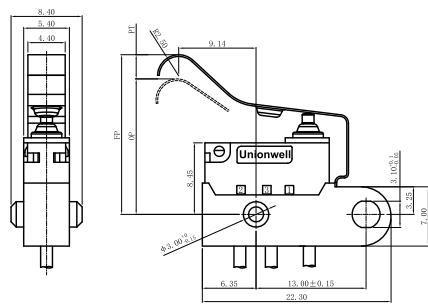

OF Max (gf)	RF Min (gf)	PT Max (mm)	OT Min (mm)	DT Max (mm)	FP Max (mm)	OP (mm)	
-130	100	25	6	1.5	2	21	15±2.0

◆ G3□□-□□□P00A52U

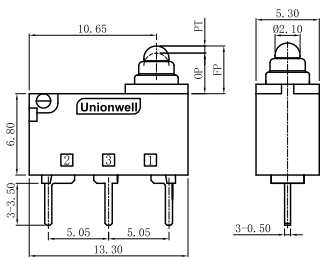

OF Max (gf)	RF Min (gf)	PT Max (mm)	OT Min (mm)	DT Max (mm)	FP Max (mm)	OP (mm)	
-130	130	30	1.3	0.6	0.25	4.2	3.4±0.3

◆ G3□□-□□□P00A53U

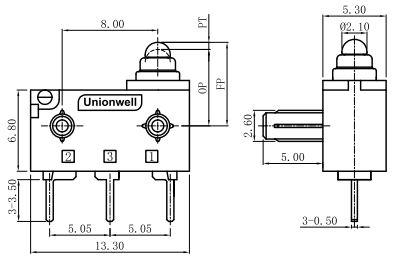

OF Max (gf)	RF Min (gf)	PT Max (mm)	OT Min (mm)	DT Max (mm)	FP Max (mm)	OP (mm)	
-130	130	30	1.3	0.6	0.25	7.2	6.4±0.3

◆ Dimensions and Operating Characteristics

◆ G3□□-□□□K00A4U

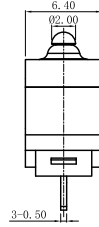
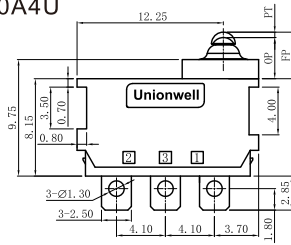

OF Max (gf)	RF Min (gf)	PT Max (mm)	OT Min (mm)	DT Max (mm)	FP Max (mm)	OP (mm)
-130	130	13	0.8	0.8	0.2	4.1

◆ G3□□-□□□K00A6U

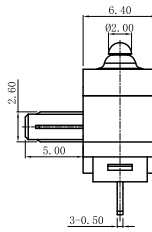
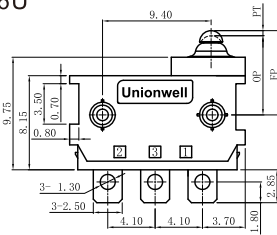

OF Max (gf)	RF Min (gf)	PT Max (mm)	OT Min (mm)	DT Max (mm)	FP Max (mm)	OP (mm)
-130	130	13	0.8	0.8	0.2	7.5

◆ G3□□-□□□S00A13U

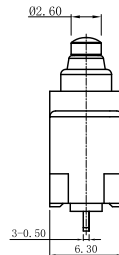
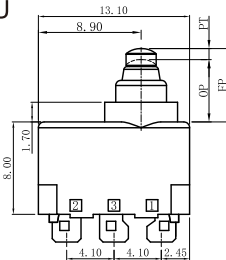

OF Max (gf)	RF Min (gf)	PT Max (mm)	OT Min (mm)	DT Max (mm)	FP Max (mm)	OP (mm)
-130	180	20	1.5	0.5	0.25	6.55

◆ G3□□-□□□S00A15U

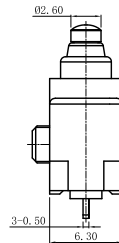
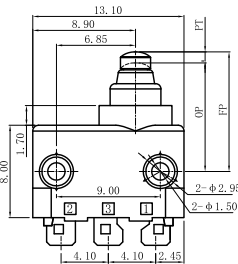

OF Max (gf)	RF Min (gf)	PT Max (mm)	OT Min (mm)	DT Max (mm)	FP Max (mm)	OP (mm)
-130	180	20	1.5	0.5	0.25	10.55

◆ G3□□-□□□S03A15U

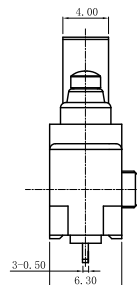
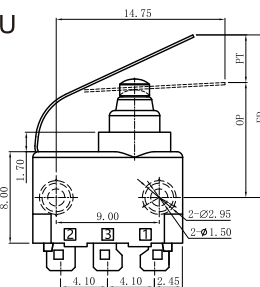

OF Max (gf)	RF Min (gf)	PT Max (mm)	OT Min (mm)	DT Max (mm)	FP Max (mm)	OP (mm)
-130	250	50	5.5	0.5	1.1	15

◆ Dimensions and Operating Characteristics

◆ G3□□-□□□S00A16U

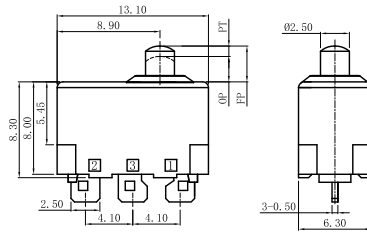

OF Max (gf)	RF Min (gf)	PT Max (mm)	OT Min (mm)	DT Max (mm)	FP Max (mm)	OP (mm)	
-130	130	8	1.5	0.5	0.25	3.3	2.2±0.3

◆ G3□□-□□□S00A18U

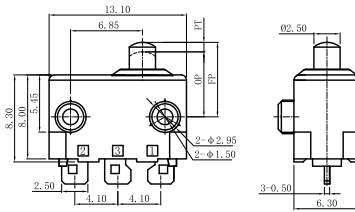

OF Max (gf)	RF Min (gf)	PT Max (mm)	OT Min (mm)	DT Max (mm)	FP Max (mm)	OP (mm)	
-130	130	8	1.5	0.5	0.25	7.3	6.2±0.3

◆ G3□□-□□□E00A47-□□U

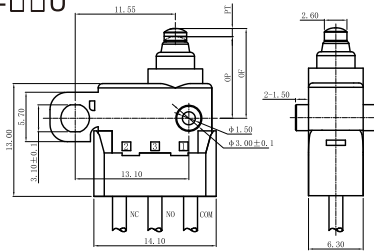

OF Max (gf)	RF Min (gf)	PT Max (mm)	OT Min (mm)	DT Max (mm)	FP Max (mm)	OP (mm)	
-130	200	20	1.5	0.5	0.25	10.55	9.4±0.3

◆ G3□□-□□□E23A47-□□U

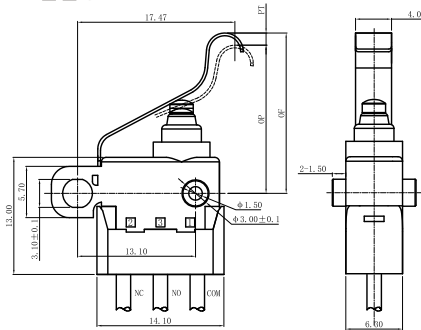

OF Max (gf)	RF Min (gf)	PT Max (mm)	OT Min (mm)	DT Max (mm)	FP Max (mm)	OP (mm)	TTP	
-130	300	50	3.5	0.5	1.1	20	16.45±1.5	14.90

◆ G3□□-□□□K00A7U

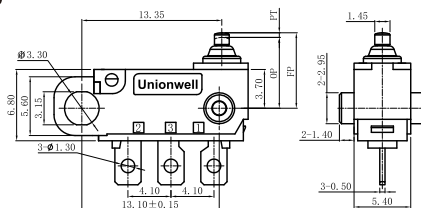

OF Max (gf)	RF Min (gf)	PT Max (mm)	OT Min (mm)	DT Max (mm)	FP Max (mm)	OP (mm)	
-130	130	13	0.8	0.8	0.2	7.35	6.75±0.2