



Flow control for high pressure differential and cavitation



WRAS Approved Materials

Applications

Reservoir inlets
Flow capacity control
Water Treatment plant
Control Pressure regulating
Turbine by pass valve

Product Attributes

High differential flow control
Cavitation control
Linear control characteristics
DN 200–2000
PN10–40 Class 150–Class300

Approvals/Standards

Flanges to EN 1092–2 as standard
Other flange Like ANSI B16.47A/B

Quality

ISO 9001:2015 Quality Management
Standard



Needle valves, sometimes referred to as plunger valves, are regulating valves and enable engineers to finely control and regulate water flow and pressure.

The DEYE plunger valve has an annular flow cross section in any open position. The valve has an optimal control behavior generating low turbulence upstream and low cavitation. The outlet flow converges towards the center of the pipeline therefore if any vapor bubbles are generated, they go to the center imploding surrounded by water without damage. The plunger is driven by a rod-crank mechanism and can be provided with additional adjusting cylinders to customize the valve behavior curve to the needs of the installation. It is a versatile valve, with low torque, which can be used as a control valve (flow, pressure, level, pumping) and The bottom discharge valve or turbine bypass.

The construction as below

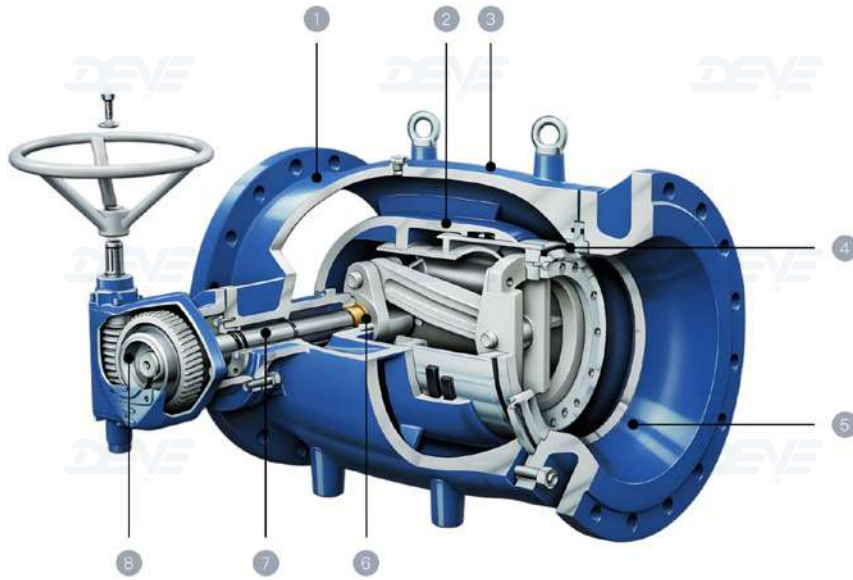

- ① Coating with WRAS approved pigments
- ② Two-way guide rails ensure smooth piston operation
- ③ The integrated valve body structure
- ④ double effect seal with metal hard seal and rubber soft seal
- ⑤ Four kinds of outlet design according to different working conditions
- ⑥ Self-lubricating brass bushing
- ⑦ dry shaft design
- ⑧ Oil-immersed, maintenance-free gearbox for life

The Outlets Options



Standard type
(Suitable for large flow condition, water head loss is very small)



Slotted Type
(flow and pressure regulation with low pressure difference)



Orifice Type
(low cavitation condition)

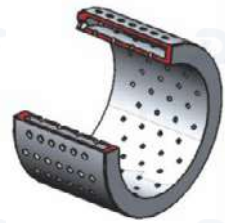

Multi-orifice Type
(High cavitation Condition)

Deye Plunger Valve Stroke

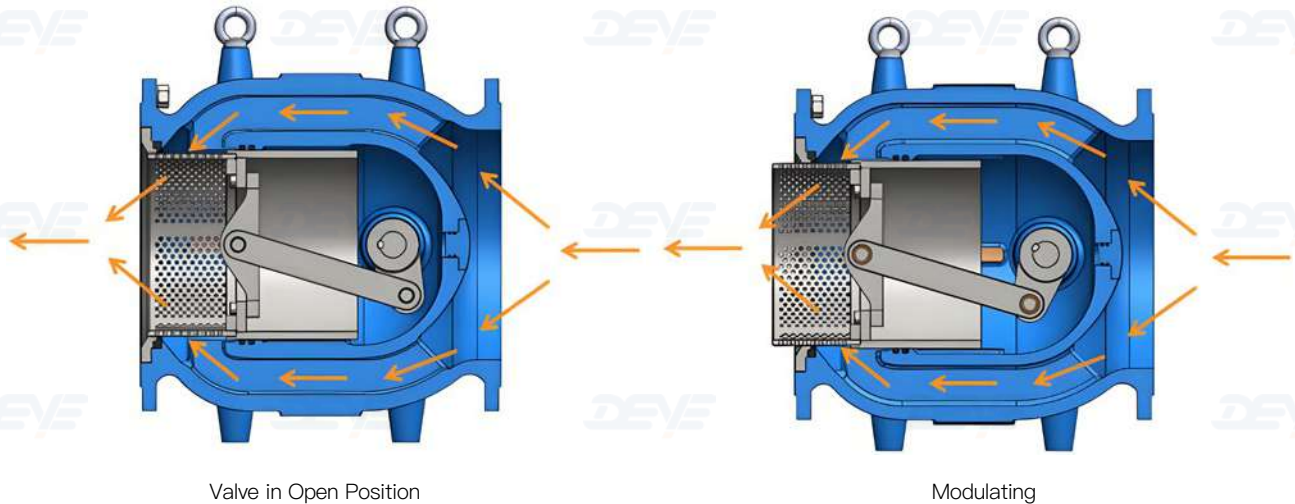

The plunger flow control valve is mainly designed for regulating flow rate and pressure in water pipelines. This regulation is achieved by the axial movement of a plunger, operated by a shaft-rod-crank mechanism. The plunger is positioned in the center of the valve, in a chamber specially shaped to protect it from the water flow and avoid noise and cavitation damage, while also ensuring vibrations-free operation. The water flow is channeled through a ring-shaped chamber around the central body of the valve. The cross section of this chamber diminishes constantly from the inlet to the outlet, causing the flow speed to rise and the pressure to drop

AS Plunger valve closes, the flow path and the piston move in the same direction of flow. When the valve is fully closed, a double O-ring seal on the rear of the piston and an EPDM sealing ring on the front provide zero leakage. The piston does not need to overcome the inlet pressure, thus keeping torque values very low.

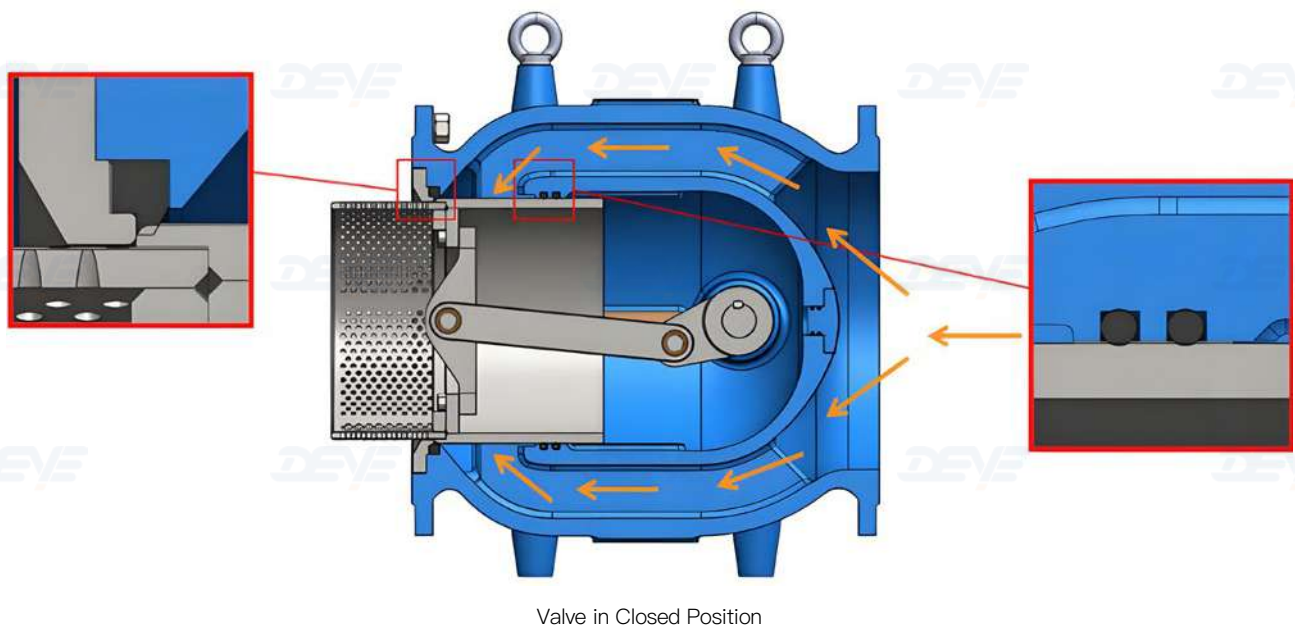

Plunger valves Advantages

- Face-to-face length acc. to EN 558-1, basic series 15 – from DN 500 1.5 x DN
- With flange ends on both sides acc. to EN 1092-2 /Class 150/Class300
- Control valve in straightway type
- With customized control device depending on operating conditions
- Low actuating torque due to pressure balanced valve piston
- Rotationally symmetrical flow guidance
- Annular flow cross section in each position
- Axial movement of the plunger by means of crank gear mechanism
- With self-locking worm gear unit including position indicator
- No blocking due to long piston guide rails
- Elastic profile sealing ring located in the no-flow zone for high durability
- Wear-resistant, corrosion-resistant and infiltration-proof piston guides in the body by micro-finished bronze weld overlay
- Piston sealed by Quad Ring

Test Standard

Field of application

DN	PN	Maximum operating pressure [bar]	Maximum operating temperature for neutral liquids [° C]
150...1200	40	40	50
150...1600	25	25	50
150...2000	16	16	50
150...2000	10	10	50

Pressure test acc. to EN 12266

Test Pressure for Body with water [bar]	Test Pressure for Seat with water [bar]
60	44
37.5	28
24	18
15	50

Operation Option

Actuator possibilities: handwheel and gearbox, electric actuator, pneumatic actuator, hydraulic brake-and-lift cylinder, own-medium pilot controlled



Application

Plunger Valves are especially suitable for drinking water, raw water and sea water

Typical applications include

- Pump start-up and control valve
- Reservoir inlet
- Control device in the bottom outlet valve of dams (with or without venting)
- Control device in the inlet and bypass of turbines
- Safety device in the bypass outlet of turbines for quick opening
- Surge anticipating device in pumping or pressurized systems.

How to make the Valve sizing

Plunger Valve Sizing



Clarify end users' systems and operating conditions



Calculate diameter, flow rate, cavitation, and adjustment range



Call database –match throttling components/empirical coefficients



Correct flow rate, pressure, cavitation coefficient

Rich experience and precise calculations ensure no cavitation



Flow-opening curve

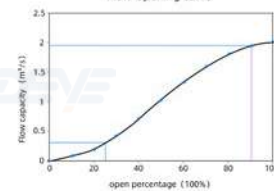

Cavitation Curve

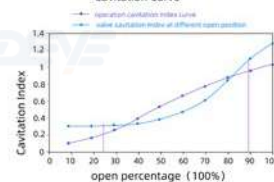

Computational Fluid Dynamics (CFD) illustration

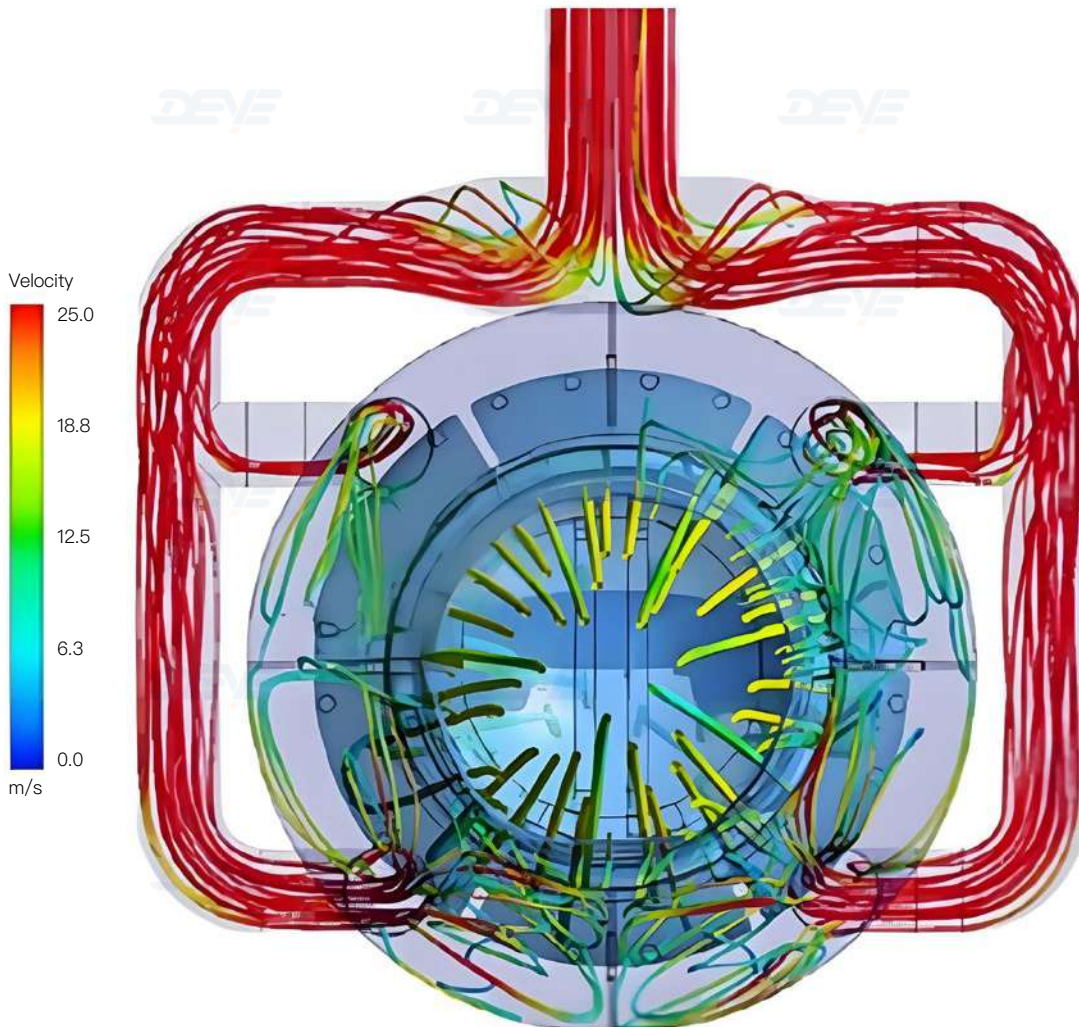
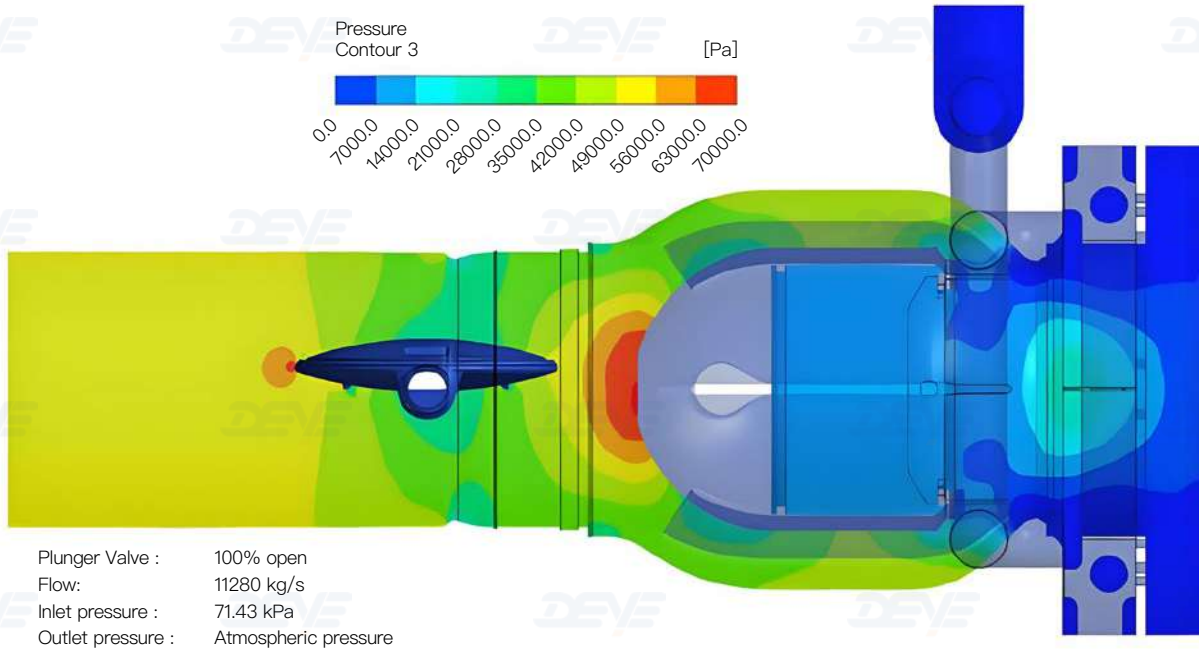

We are sizing the correct valve according to the specific process data, please provide the following

- | | |
|---|--------------------|
| 1) Inlet pressure | 2) Outlet Pressure |
| 3) Alternatively, desired differential pressure | 4) Flow Rate |

we will provide Kvs values along with a flow graph of the valve control performance.

<p>Valve flow coefficient, Kv or Cv</p> $Kv(Cv) = Q \sqrt{\frac{Gf}{\Delta P}}$	<p>Where:</p> <p>Kv = Valve flow coefficient (flow in m³/h at 1bar Diff. Press.) CV = Valve flow coefficient (flow in gpm at Diff. Press. 1 psi) Q=Flow rate (m³/h ; gpm) AP = Differential pressure (bar; psi) Gf = Liquid specific gravity (Water=1.0)</p>
<p>Flow resistance or Head loss coefficient</p> $K = \Delta H \sqrt{\frac{2g}{V^2}}$	<p>Where:</p> <p>K=Flow resistance or Head loss coefficient (dimensionless) AH = Head loss (m ; feet) V= Nominal size flow velocity (m /sec ; feet /sec.) g=Acceleration of gravity (9.81 m/sec², 32.18 feet/sec²)</p>

Linear Flow Characteristics (a referenced case to show how to choose right valve to meet flow rate required)

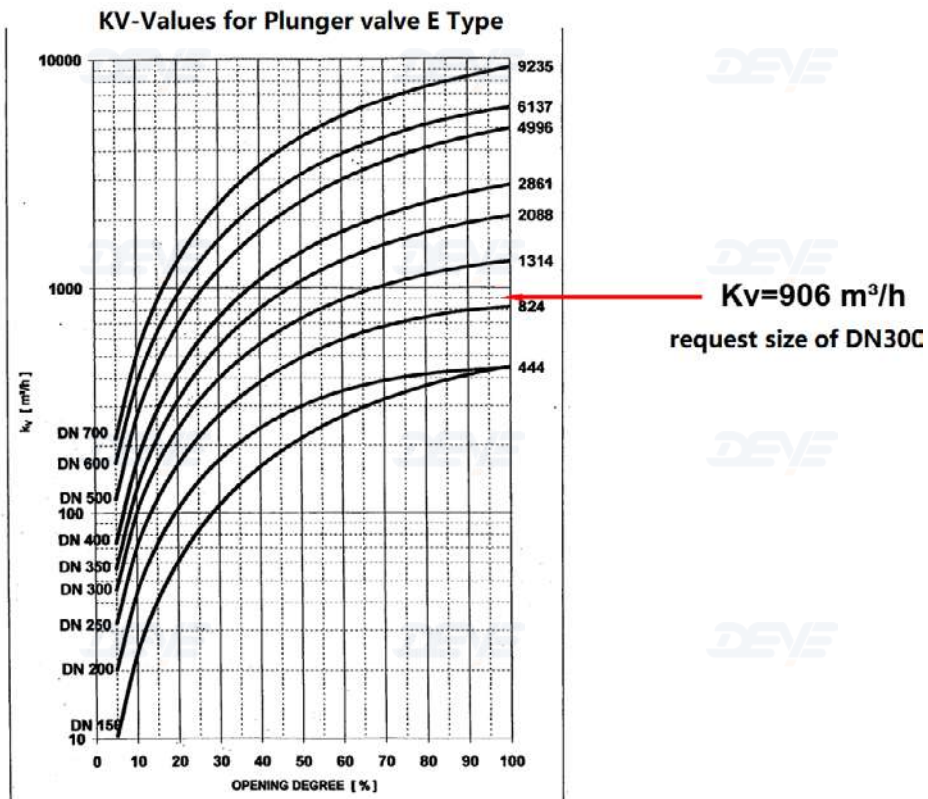

How to choose outlet Design to anti-cavitation

1) Cavitation occurs

There are three fundamental requirements for cavitation to occur. First, there must be gas bubbles (nuclei) or voids in the fluid that serves as a basis for vaporization to occur. Second, the internal pressure in the fluid must drop to or below vapor pressure. Third, the pressure surrounding the vapor bubble must be greater than the vapor pressure for it to collapse.

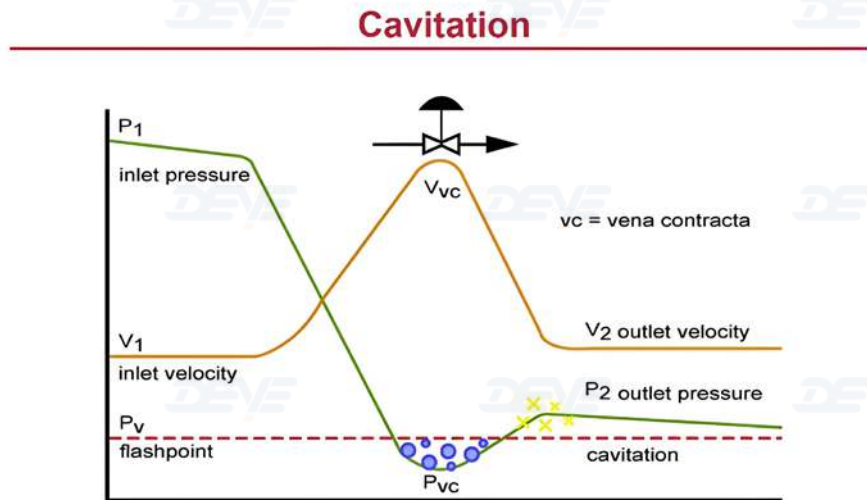

2) Eliminated the cavitation: (Anti-cavitation design of the plunger valve)

Cavitation prevention and protection is an important consideration in the design and operation of valves used in water distribution systems. One should be able to determine if cavitation exists, and if so its intensity and effects on the system. Cavitation in valves is a destructive condition that seriously affects the operation and service of the valve and occurs when fluid passing through the valve lowers to the vapor pressure of the fluid causing vapor

cavities (bubbles) to form. When the fluid passes out of the low-pressure area into a higher-pressure area, the vapor cavity becomes unstable and collapses. This collapse is what can sometimes be heard or seen and is the reason we must be concerned about its presence in pipeline systems. The collapse can be violent and is accompanied by noise, vibrations, and possible erosion damage to the valve or surrounding pipeline.

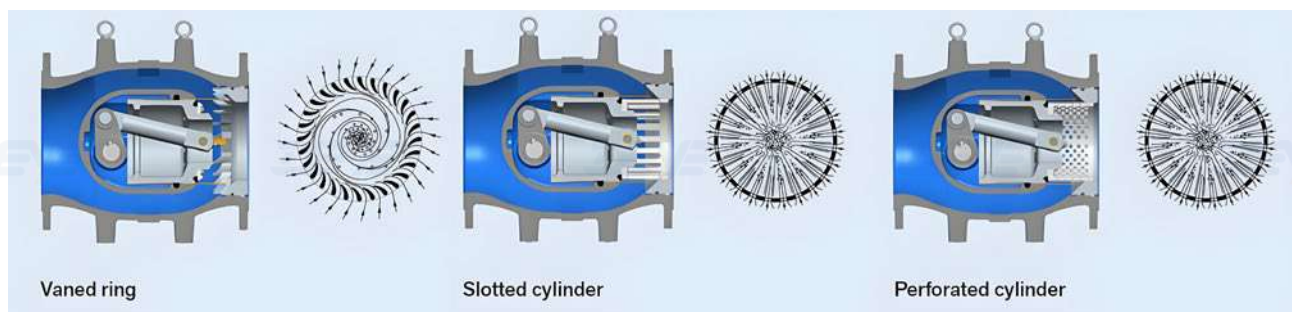
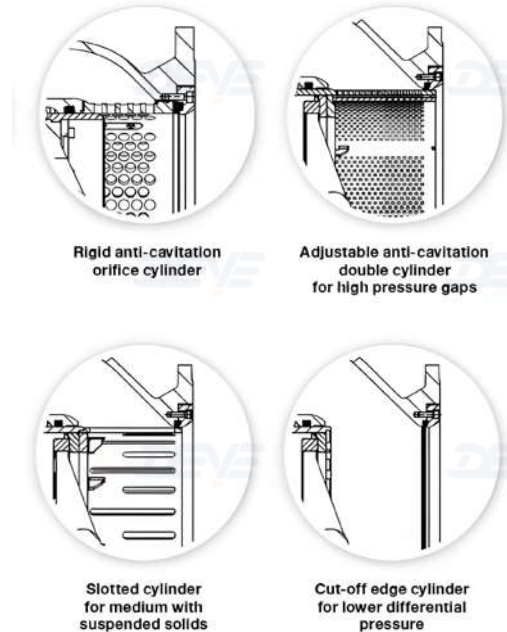

Cavitation diagram 'sigma'

'Sigma' is the cavitation index that most widely-used to quantify and predict cavitation in regulation/control valve

Below is an example to show how to choose proper valve according to sigma index

Sigma $\sigma=1.75$
choose the
plunger valve
Type E

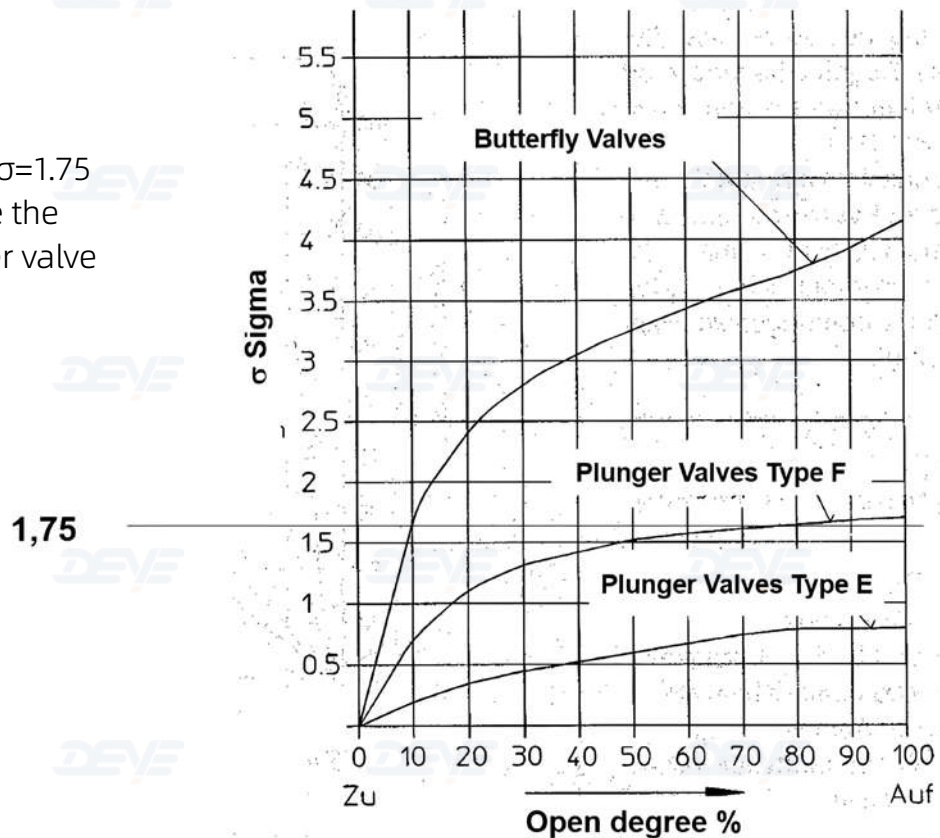

The cavitation risk in needle valves can be evaluated using the following equation: $\sigma > \sigma_L$

The valve won't operate under cavitation until $\sigma > \sigma_L$. (σ_L is the valve performance Sigma Index)

Where is it:

- Cavitation value $\sigma = P_{out} / (\Delta P + v^2/2g)$
- Cavitation limit σ_L see diagram
- ΔP = head loss [mhw]
- P_{out} = valve outlet pressure
- v = fluid velocity referred to DN [m/s]
- $g = 9.81 \text{ m/s}^2$

The valve shall not continuously operate under cavitation risk conditions. it can be accepted that the valve operates under slight cavitation conditions for short periods.

How to reduce the Noise

Plunger valves can be used to reduce noise in fluid systems, particularly in applications involving high flow rates and pressures where cavitation and vibration can be problematic. Their design minimizes noise and vibration by managing flow in a way that reduces turbulence and prevents cavitation.

Controlled Flow Path

Plunger valves direct the flow around a central plunger within a specially shaped chamber. This design minimizes turbulence, which is a primary cause of noise in fluid systems.

Pressure Balance

The design of the flow path helps to balance the pressure within the valve, further reducing the potential for cavitation and vibration, which are major contributors to noise.

Cavitation Prevention

By managing flow and pressure, plunger valves minimize the formation of cavitation bubbles. Cavitation, the rapid formation and collapse of vapor bubbles in a fluid, generates significant noise and vibration.

Vibration Reduction

The smooth, controlled flow path and pressure balance in plunger valves contribute to a reduction in overall vibration, which in turn helps to minimize noise.

Linear Flow Characteristics

The linear flow characteristics of plunger valves allow for precise control of flow rate and pressure, further contributing to noise reduction by minimizing sudden changes in flow velocity.

Acoustic Energy Level

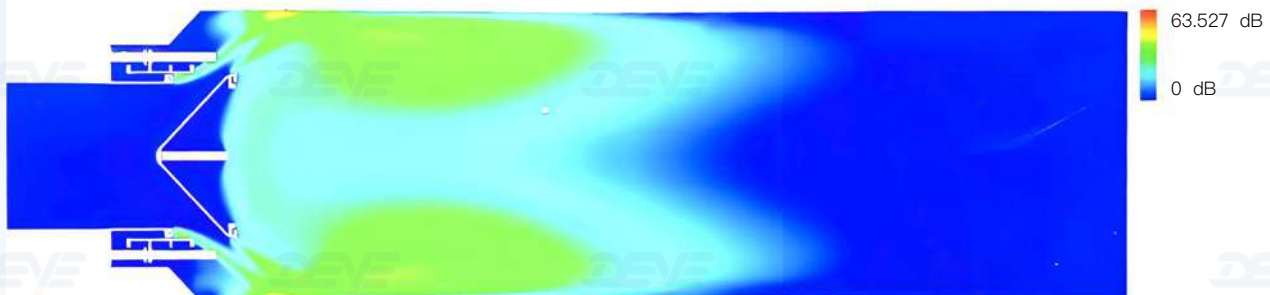

Min = 0 (dB) Max = 63.527 (dB) Iteration = 360

Noise-travel curve

Noise level (dB A)

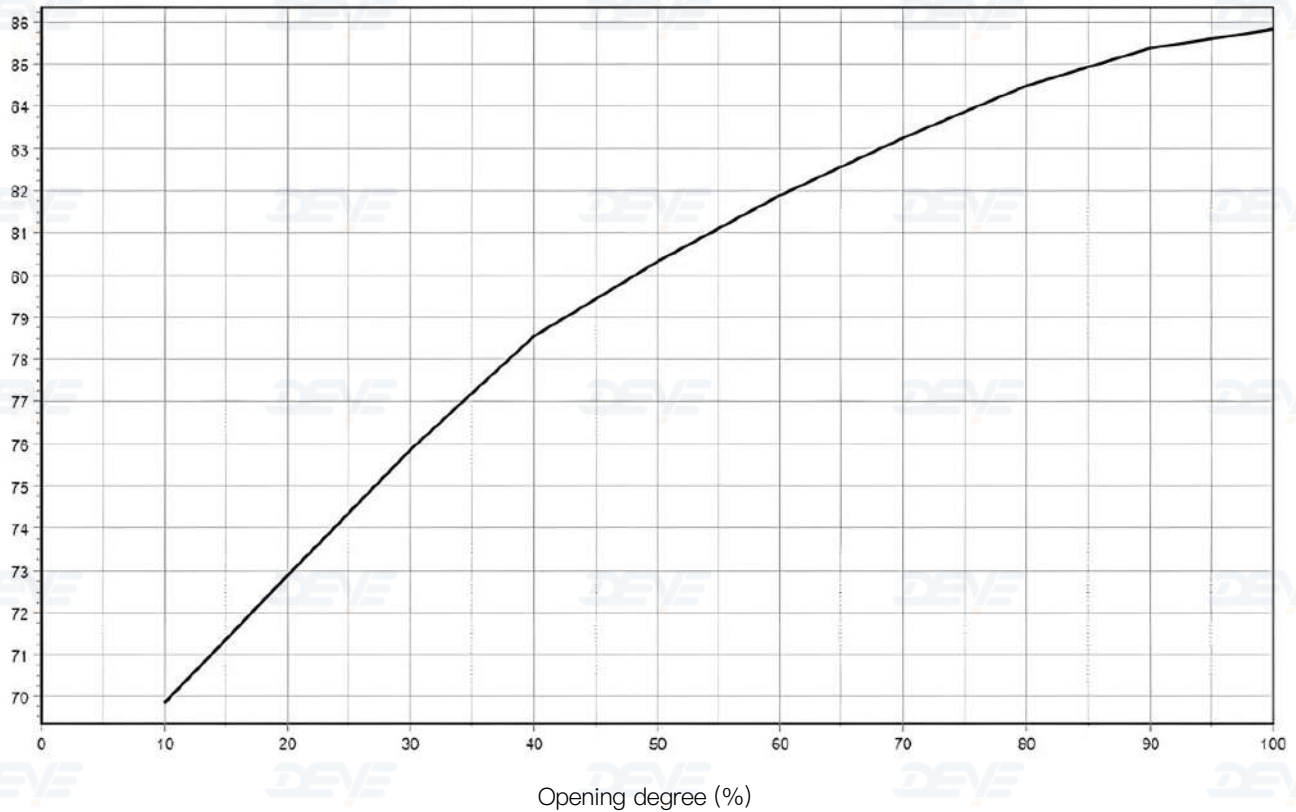

When the opening is 100%, the valve operating noise is <86 decibels; When projects need $D_b < 80$, adjust the cage

Dimension

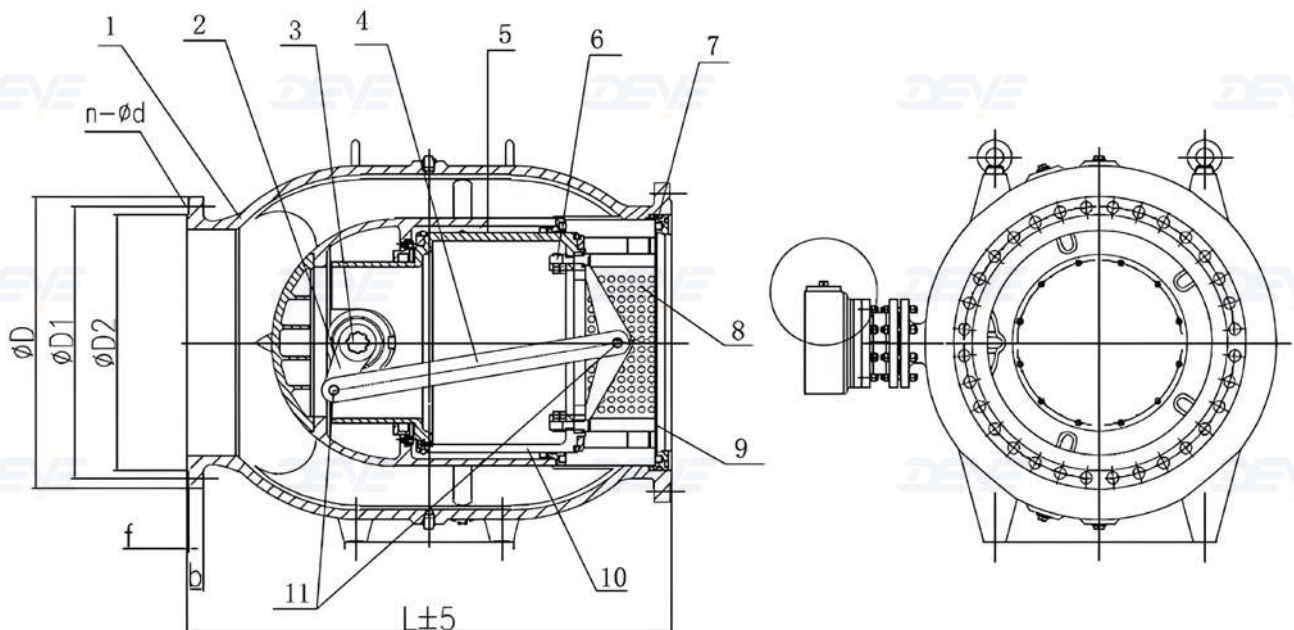

NO	NAME	MATERIAL
1	BODY	ASTM A216 WCB
2	STEM	ASTM A182 F51
3	STEM	F51 optional 17-4PH
4	STEM	F51 optional 17-4PH
5	PLUG	ASTM A276 SS316L
6	BOLT	SO 3506 A4-70
7	SEAL	ASTM A276 SS316L
8	MOUSE CAGE	ASTM A276 SS316L
9	SEAL	SS316L
10	GUIDE	ASTM A276 SS316L
11	BOLT	ISO 3506 A4-70



Class 150LBS DN200–DN1800

DN	L	D	D1	D2	b	f	n-φd
DN200	400	345	298.5	270	29	1.6	8-22
DN300	500	485	432	381	32	1.6	12-26
DN400	620	600	540	470	37	1.6	16-28
DN500	750	700	635	584	43	1.6	20-32
DN600	900	815	749.5	692	48	1.6	20-35
DN700	1040	927	863.5	800	44.5	1.6	28-35
DN800	1200	1060	978	914.5	46	1.6	28-41
DN900	1350	1170	1086	1022	52.5	1.6	32-41
DN1000	1500	1290	1200	1124	56	1.6	36-41
DN1100	1650	1405	1314.5	1244.5	60.5	1.6	40-41
DN1200	1800	1511	1422.5	1359	65	1.6	44-41
DN1300	1950	1625	1536.5	1460.5	70	1.6	44-48
DN1400	2100	1746	1651	1575	73.5	1.6	48-48
DN1500	2250	1855	1759	1676.5	76.5	1.6	52-48
DN1800	2700	2197	2095	2000	67	1.6	60-48

Class 300LBS DN200–DN900

DN	L	D	D1	D2	b	f	n-φd
DN200	435	380	330	270	41.5	1.6	12-26
DN300	545	520	451	381	51	1.6	16-32
DN400	675	650	571.5	470	57.5	1.6	20-35
DN500	790	775	686	584	63.5	1.6	24-35
DN600	950	915	813	692	70	1.6	24-41
DN700	1140	1035	940	800	86	1.6	28-45
DN800	1330	1150	1054	914.5	98.5	1.6	28-51
DN900	1450	1270	1168.5	1022.5	105	1.6	32-55

EN1092-2 PN10

DN	L	D	D1	D2	b	f	n- ϕ d
DN200	400	340	295	268	20	3	8-22
DN300	500	445	400	370	24.5	4	12-22
DN400	620	565	515	482	24.5	4	16-26
DN500	750	670	620	585	26.5	4	20-26
DN600	900	780	725	685	30	5	20-30
DN700	1040	895	840	800	32.5	5	24-30
DN800	1200	1015	950	905	35	5	24-33
DN900	1350	1115	1050	1005	37.5	5	28-33
DN1000	1500	1230	1160	1110	40	5	28-36
DN1200	1800	1455	1380	1330	45	5	32-39
DN1400	2100	1675	1590	1535	46	5	36-42
DN1600	2400	1915	1820	1760	49	5	40-50
DN1800	2700	2115	2020	1960	52	5	44-50
DN2000	3000	2325	2230	2170	55	5	48-50

EN1092-2 PN16

DN	L	D	D1	D2	b	f	n- ϕ d
DN200	400	340	295	268	20	3	12-22
DN300	460	410	378	24.5	4	12-26	20-33
DN400	620	580	525	490	28	4	16-30
DN500	750	715	650	610	31.5	4	20-33
DN600	900	840	770	725	36	5	20-36
DN700	1040	910	840	795	39.5	5	24-37
DN800	1200	1025	950	900	43	5	24-41
DN900	1350	1125	1050	1000	46.5	5	28-41
DN1000	1500	1255	1170	1115	50	5	28-44
DN1200	1800	1485	1390	1330	57	5	32-50
DN1400	2100	1685	1590	1530	60	5	36-50
DN1600	2400	1930	1820	1750	65	5	40-57
DN1800	2700	2130	2020	1950	70	5	44-57
DN2000	3000	2345	2230	2150	75	5	48-62

EN1092-2 PN25

DN	L	D	D1	D2	b	f	n- ϕ d
DN200	400	360	310	278	22	3	12-26
DN300	500	485	430	395	27.5	4	16-31
DN400	620	620	550	505	32	4	16-37
DN500	750	730	660	615	36.5	4	20-37
DN600	900	845	770	720	42	5	20-41
DN700	1040	960	875	820	46.5	5	24-44
DN800	1200	1085	990	930	51	5	24-50
DN900	1350	1185	1090	1030	55.5	5	28-50

EN1092-1 PN40

DN	L	D	D1	D2	b	f	n-φd
DN200	400	375	320	285	34	3	12-30
DN300	500	515	450	410	42	4	16-33
DN400	620	660	585	535	50	4	16-39
DN500	750	755	670	615	57	4	20-42
DN600	900	890	795	735	72	5	20-48
DN700	1040	995	900	840	68	5	24-48
DN800	1200	1140	1030	960	76	5	24-56
DN900	1350	1250	1140	1070	79	5	28-56

Installation

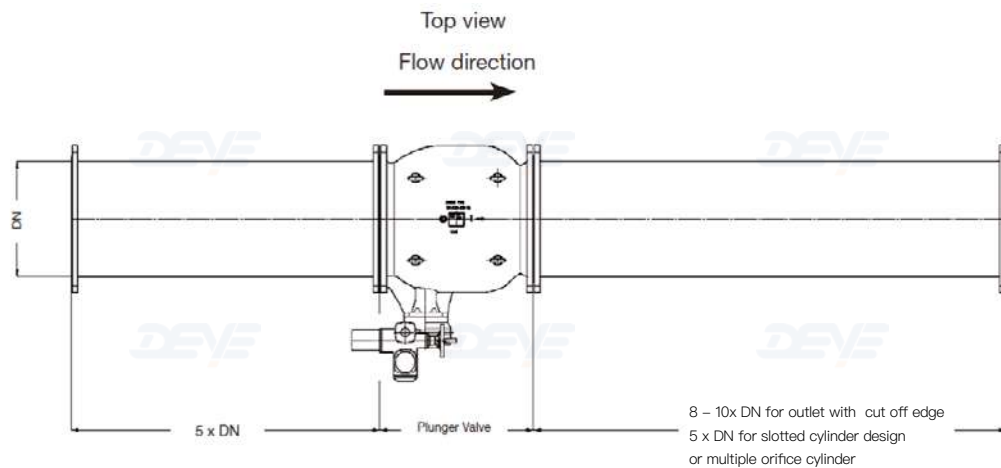

DEYE Plunger Valves can be installed in the vertical as well as in the horizontal position. The valve will not operate in any other pipeline position. The flow-through direction arrow has to be observed. Pay attention to the direction of operation arrow on the valve body.

Installed equipment in the pipeline upstream and downstream of the DEYE Plunger Valve:

- When using polluted mediums, a filter with a suitable mesh size has to be provided upstream of the valve to sustain the function of the control valve.
- Avoid installing an inspection valve, elbows, T-pieces and Filters directly upstream of the Plunger Valve (5 x DN) as this may cause irregular upstream flow and thus disturb the function of the control valve.
- When installing the Plunger Valve as a control valve in a closed pipeline, it has to be strictly observed that a straight outlet section is provided downstream of the Plunger Valve like.:
 - for version with outlet orifice hole, the length of this section should be 8 -10 x DN.
 - for version with multiple orifice or slotted cylinder, this length should be minimum 5 x DN.
- This means that fittings like elbows, T-pieces, Butterfly Valves. Non-return Valves or y-filters must not be installed within this pipe section. By this the turbulent flow in the flow profile influenced by the Plunger Valve can be calmed. If these preconditions cannot be fulfilled; one has to expect with more noise and damages at the corresponding components. Avoid arranging diffusers on the outlet side. In this case, the Plunger Valves can be factory-mounted

with a sudden enlargement. If the distances required for inlet and outlet zones can not be complied with this way, this may result in disturbances of the Plant or inferior control behavior.

- The temperature limits for the flow medium must not be exceeded.
- The nominal pressure is the max. pressure to be applied on the closed valve.
- Extending the operating elements is not allowed, by e.g. levers.

Trouble Shooting

For all maintenance and repair work please observe the general safety instructions under table

Problem	Possible Cause	Remedial action
Valve makes noise	Unfavorable installation position and thus unfavorable flow at the valve (e.g. Installed too closely behind the elbow)	Change installation position
	Valve operating beyond the design limits	Check design and/or operational data; if required, change resistance in valve by using other internals.
Valve Stuck	Foreign particle jammed in the seat area	Flush valve, if required, disassemble valve and remove foreign object
	Gear Blocked	Dissolving the blockage
	Electric actuator not yet connected to power supply	Connect to power supply
Seat Leakage	Unfavorable flow at the valve and obstruction of the movement	Change installation position
	Valve not completely closed yet	Close the valve completely
	Valve sealing damaged or worn	Replace the seat Ring
Request flow capacity is not reached	Operational data have been changed	Check design and/or operational data; if required, change resistance in valve by using other internals.
	Dimensions of multiple-orifice or slotted cylinders too small.	
Flow volume is too big	Multiple-orifice or slotted cylinders optionally are clogged.	Flush valve; if required, disassemble valve and remove foreign object
	Operational data have been changed	Check design and/or operational data; if required, change resistance in valve by using other internals.
Desired back pressure too high	Dimensions of multiple-orifice or slotted cylinders to large	Check design and/or operational data; if required, change resistance in valve by using other internals
	Operational data have been changed	
Cavitation in valve	Valve operating beyond the design limits	Check design and/or operational data; if required, change resistance in valve by using other internals
	Operational data have been changed	



Shijiazhuang Deye Piping Industry Co., Ltd

📍 Add.No.368 Youyi St. Shijiazhuang City, Hebei, P.R.China

☎ 0086311 85335190
0086 13292824811 (wechat /WhatsApp)

✉ sales@deyepiping.com
🌐 www.deyepiping.com