

UPKTECH FR-670 Scraper Cleaning Machine

I. Description:

This equipment is used for scraper cleaning of printing machines, such as cleaning residual solder paste, dust, etc. The "scraper cleaning machine" uses technologies such as high-pressure spray cleaning, ultrasonic cleaning, rolling rinsing, large-flow fan hot air drying, etc. to ensure the cleaning effect. Integrated cleaning, rinsing, air cutting and drying functions. The time and speed of adding and draining liquid, cleaning and rinsing can be set through the human-machine interface.



II. Features:

1. Check whether the power supply and power cord are properly connected to ensure stable power supply.
2. Check whether the control panel and buttons are working properly and ensure that the device switches and settings are correct.
3. Check the sensors and safety devices to ensure they are functioning properly and not triggering false signals.

III. Internal structure:

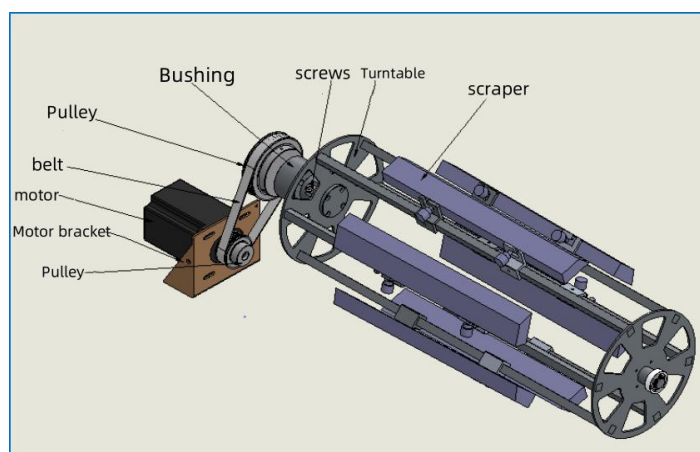

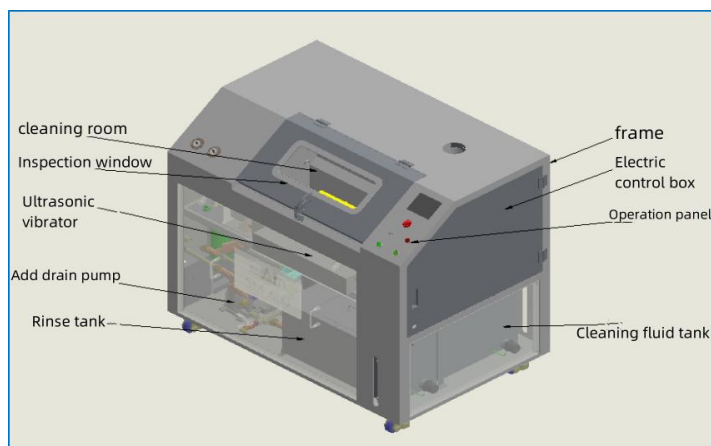

IV. Specifications:

Model	FR-670
equipment dimensions	1440*1150*1240
Diameter of the working basket	200mm
Maximum length of squeegee	600mm
workbasket loads	20KG
gas pressure range	0.4-0.6Mpa
Tank capacity	60L
Spray pressure	0.15-0.3Mpa
Maximum power	18KW
voltage/frequency	380V/50HZ
Recommended cleaning agents	Aqueous cleaning agent FR-6001